

Weak vertical composition II: totalities

CHENG, Eugenia and CORNER, Alexander

Available from Sheffield Hallam University Research Archive (SHURA) at:

<https://shura.shu.ac.uk/34241/>

This document is the author deposited version. You are advised to consult the publisher's version if you wish to cite from it.

Published version

CHENG, Eugenia and CORNER, Alexander (2024). Weak vertical composition II: totalities. *Theory and Applications of Categories*, 41 (31), 995-1043. [Article]

Copyright and re-use policy

See <http://shura.shu.ac.uk/information.html>

WEAK VERTICAL COMPOSITION II: TOTALITIES

EUGENIA CHENG, ALEXANDER S. CORNER

ABSTRACT. We continue our study of semi-strict tricategories in which the only weakness is in vertical composition. We assemble the doubly-degenerate such tricategories into a 2-category, defining weak functors and transformations. We exhibit a biadjoint biequivalence between this 2-category and the 2-category of braided (weakly) monoidal categories, braided (weakly) monoidal functors, and monoidal transformations.

Contents

Introduction	995
1 \mathbf{Bicat}_s -categories via distributive laws of 2-monads	998
2 Algebras via distributive laws	1014
3 Weak maps and transformations of doubly-degenerate \mathbf{Bicat}_s -categories	1022
4 Biadjoint biequivalence	1032
A String diagram calculations	1033

Introduction

In this paper we continue the study of weak vertical composition begun in [CC22]. We study semi-strict tricategories in which everything is strict except vertical composition, that is, composition along bounding 1-cells. These tricategories can be conveniently constructed as categories enriched in \mathbf{Bicat}_s , the category of bicategories and strict functors, with monoidal structure given by cartesian product.

In [CC22] we showed that any doubly-degenerate \mathbf{Bicat}_s -category X has an underlying braided monoidal category UX , and that given any braided monoidal category B there is a doubly-degenerate \mathbf{Bicat}_s -category ΣB such that $U\Sigma B$ is braided monoidal equivalent to B . This shows that weak vertical composition is “enough” to achieve braided monoidal categories in the doubly-degenerate case, a typical test case for whether a theory of tricategories is fully weak, and a special case of the study of k -degenerate n -categories [BD95, CG07, CG11, CG14].

That work followed on from [JK07] which proved an analogous result for semistrict tricategories in which everything is strict except weak horizontal units. However, in both cases the totalities of the structures in question were not studied.

Received by the editors 2023-09-01 and, in final form, 2024-08-05.

Transmitted by Kate Ponto. Published on 2024-08-21.

2020 Mathematics Subject Classification: 18D05, 18D10, 18D20.

Key words and phrases: tricategory, degenerate, braided monoidal category, enrichment, icon.

© Eugenia Cheng, Alexander S. Corner, 2024. Permission to copy for private use granted.

In this paper we extend the comparison to totalities. That is, we assemble doubly-degenerate \mathbf{Bicat}_s -categories into a 2-category and exhibit a biequivalence with the 2-category of braided monoidal categories; this extends the object-level comparison of [CC22].

The first task then is to construct a suitable 2-category of doubly-degenerate \mathbf{Bicat}_s -categories. In order to make an equivalence with the 2-category of braided monoidal categories we need to consider braided monoidal functors that are only weakly monoidal, so to make a good comparison with doubly-degenerate \mathbf{Bicat}_s -categories we use weak maps of those as well. So the first step is to make that definition. Note that as in [CG11, CG14] we do not simply take homomorphisms, transformations and modifications of tricategories as this gives the “wrong” structure in the doubly-degenerate case. One issue is that this would not be expected to form a 2-category; *a priori* tricategories and their higher morphisms assemble into a tetracategory that does not truncate to a coherent 2-dimensional structure. Another issue is that fully weak homomorphisms and transformations of tricategories give too much extraneous structure in the doubly-degenerate case, in the form of distinguished invertible elements arising as higher-dimensional constraint cells relating to degenerate dimensions; the idea is that degenerate dimensions should not give rise to constraint cells, but rather, we should start with some semi-strict versions of weak functors and transformations that are strict with respect to dimensions that are going to become degenerate.

To address both of these issues we follow [CG11, CG14] and use Lack’s icons in a higher-dimensional generalisation [Lac10] to ensure a coherent 2-category totality and the “correct” functors and transformations for the doubly-degenerate structures. The idea behind icons is that they are “identity component oplax natural transformations”, but the key is that the identity components are ignored and replaced by an assertion that the source and target homomorphisms agree on 0-cells. This means that the only components are 2-cells and thus icons compose strictly, so bicategories, homomorphisms and icons form a strict 2-category. The process can be iterated [CG14] to give 2-dimensional totalities of weak n -categories where restricting to the $(n - 1)$ -degenerate n -categories then results in an appropriate 2-category of categories with extra structure (monoidal, braided monoidal, or symmetric monoidal). We refer to these higher dimensional iterated versions generally as “icon-like” or “iconic”; the first step in this work is to make an iconic 2-category of doubly-degenerate \mathbf{Bicat}_s -categories.

In [CC22] we characterised doubly-degenerate \mathbf{Bicat}_s -categories as a semi-strict form of 2-monoidal category [AM10] (that is a category with two monoidal structures and interchange) in which one tensor product is weak but the other tensor product and interchange are strict. This suggests a characterisation of weak functor as a weak monoidal functor with respect to each monoidal structure, together with some interaction axiom(s). To put this on a secure footing we will proceed abstractly via monads and distributive laws. In Section 1 we construct \mathbf{Bicat}_s -categories as algebras for a 2-monad on the 2-category Cat-2-Gph of 2-graphs enriched in \mathbf{Cat} (equivalently graphs enriched in $\mathbf{Cat-Gph}$). This 2-category has iconic 2-cells, so all further constructions are then automatically iconic.

The 2-monad in question is a composite of a 2-monad V for vertical composition and a 2-monad H for horizontal composition, composed via a strict distributive law $VH \Longrightarrow HV$ coming from strict interchange. We then have a 2-category of algebras for the composite 2-monad, weak maps of algebras, and transformations. This is the 2-category of \mathbf{Bicat}_s -categories that we want, but we need to unravel the definitions somewhat in order to compare it with maps of braided monoidal categories.

In Section 2 we do some preliminary examination of structures arising from a 2-dimensional distributive law of general 2-monads S over T . We characterise strict TS -algebras via a T -algebra and S -algebra structure together with an interaction axiom; we characterise a weak map of TS -algebras as a weak map with respect to the T -algebra structure and to the S -algebra structure, together with an interaction axiom. Transformations are just transformations of the T -structure and the S -structure, with no further interaction axiom required.

In Section 3 we unravel those definitions in our case of interest. We re-characterise doubly-degenerate \mathbf{Bicat}_s -categories as braided monoidal categories in steps:

1. First we express them as HV -algebras.
2. We then re-express them as an H -algebra and V -algebra structure satisfying an interaction axiom coming from the distributive law (that is, a horizontal and vertical monoidal structure with interchange).
3. Finally we express them as a V -algebra (monoidal category) with a braiding coming from a weak Eckmann–Hilton argument.

We re-characterise a weak map of doubly-degenerate \mathbf{Bicat}_s -categories as a braided monoidal functor via the corresponding steps:

1. We start with a weak map of HV -algebras.
2. We re-express it as a weak map of H -algebras and a weak map of V -algebras, with an interaction condition relating to the distributive law.
3. Finally we re-express it as just a weak map of V -algebras plus a braiding condition.

Our overall aim is to relate (1) to (3), and (2) mediates between those steps for us. Section 2 takes us from (1) to (2), and Section 3 takes us from (2) to (3) in our specific case.

We use a weak Eckmann–Hilton argument to show that a weak map of doubly-degenerate HV -algebras in our case can be characterised as just a weak map of the V -structures interacting well with the braiding (which itself comes from an Eckmann–Hilton argument); conversely, such a weak map of doubly-degenerate V -algebras can be given the structure of a weak map of HV -algebras. We characterise transformations similarly, and show that a transformation of the V -structures is automatically a transformation of the H -structures.

We are then ready to construct a biadjoint biequivalence. In Section 4 we extend the assignment U defined in [CC22] to a 2-functor

$$U \underline{\underline{\text{dBicat}_s\text{-Cat}}} \longrightarrow \underline{\underline{\text{BrMonCat}}}.$$

Biessential surjectivity was shown in [CC22]; local essential surjectivity on 1-cells follows from Section 3, and local full and faithfulness on 2-cells follows from Section 3.10. Then by [Gur12] we have the main theorem:

MAIN THEOREM. The 2-functor $\underline{\underline{\text{dBicat}_s\text{-Cat}}} \xrightarrow{U} \underline{\underline{\text{BrMonCat}}}$ is part of a biadjoint biequivalence of 2-categories.

Note that constructing a pseudo-inverse is non-trivial and we defer it to a sequel.

Finally it is worth noting that weak vertical units are much easier to deal with than weak horizontal units, as it is the weak horizontal 1-cell units that make the weak Eckmann–Hilton argument tricky in a general tricategory (see for example [CG11]). Using weak vertical units but strict horizontal ones avoids that technical issue.

HOW TO READ THIS PAPER QUICKLY.

1. Section 1.28 gives the 2-category totality of Bicat_s -categories with strict maps.
2. Theorem 2.12 gives the characterisation of weak maps of TS -algebras via a T -structure and S -structure.
3. Section 3 contains the main content of the comparison with braided monoidal categories.
4. The Main Theorem (4.1) follows immediately.

TERMINOLOGY AND NOTATION CONVENTIONS.

- We use “strict” when axioms hold on the nose and “weak” when axioms hold up to specified constraint isomorphisms.
- Section 1.18 is concerned with a careful construction of 2-categorical structures, so in that section we adopt a double-underline notation for 2-category totalities to distinguish them from 1-category totalities.
- The Appendix contains various proofs using string diagrams.

1. Bicat_s -categories via distributive laws of 2-monads

In this section we construct a suitable totality of Bicat_s -categories for our comparison. Bicat_s -categories can be thought of as a form of semi-strict tricategory, and we will eventually be studying the doubly-degenerate ones, that is, those with only one 0-cell and only one 1-cell.

The two subtle features for our totality of \mathbf{Bicat}_s -categories are that it needs to have appropriately weak maps (not fully weak), and that it needs to be 2-dimensional, rather than fully 4-dimensional which is what we might otherwise expect for semi-strict tricategories. The work of [CG14] showed that the “correct” approach for totalities of doubly-degenerate higher categories is via iterated icons rather than via the fully weak maps.

A fully weak map of doubly-degenerate \mathbf{Bicat}_s -categories would include functoriality constraints for composition of 1-cells. However, [CG11] showed that this is the “wrong” notion for doubly-degenerate situations, because even if there is only one 0-cell and one 1-cell, any constraint 2-cell would remain as a distinguished invertible element; that is, when we perform the dimension shift, the old 2-cells become 0-cells of a new lower-dimensional structure (in our case a putative braided monoidal category), and the constraint 2-cells would become distinguished invertible 0-cells, adding unwanted extra structure to our braided monoidal category.

We eliminate that issue by using stricter functors, specifically, functors that are strictly functorial on any dimension of cell that is going to become degenerate. In our case, that means we want functors that are strictly functorial with respect to 1-cell composition, and only have functoriality constraints with respect to 2-cell composition. This is effected technically by our use of icons, because the existence of an iconic 2-cell constraint encodes an assertion that the source and target agree on objects.

Moreover, we wish to express doubly-degenerate \mathbf{Bicat}_s -categories via a distributive law between 2-monads, as this gives us a convenient framework for defining weak maps between them; weak maps are difficult to define in generality for higher categories.

Both of these issues are resolved by making the construction via 2-monads on the 2-category Cat-Gph-Gph. The algebras for the resulting 2-monad immediately form a 2-category, with 2-cells that are immediately iconic. That is the content of this section.

The 2-dimensional distributive law in question is just a 2-dimensional extension of a 1-dimensional distributive law that is already established [Che11a, CL19] so we will begin with an overview of the 1-dimensional version.

1.1. PRELIMINARIES ON DISTRIBUTIVE LAWS. Distributive laws were introduced by Beck in [Bec69] and are a way of combining two algebraic structures in a coherent way. We first recall the definitions and main results that we will be building on.

1.2. DEFINITION. [Bec69] *Let S and T be monads on a category \mathcal{C} . A distributive law of S over T consists of a natural transformation $\lambda ST \Rightarrow TS$ such that the following diagrams commute.*

$$\begin{array}{ccc}
 & T & \\
 \eta^{ST} \swarrow & & \searrow T\eta^S \\
 ST & \xrightarrow{\lambda} & TS
 \end{array}
 \qquad
 \begin{array}{ccccc}
 S^2T & \xrightarrow{S\lambda} & STS & \xrightarrow{\lambda S} & TS^2 \\
 \mu^{ST} \downarrow & & & & \downarrow T\mu^S \\
 ST & \xrightarrow{\lambda} & & & TS
 \end{array}$$

$$\begin{array}{ccc}
 & S & \\
 S\eta^T \swarrow & & \searrow \eta^T S \\
 ST & \xrightarrow{\lambda} & TS
 \end{array}
 \qquad
 \begin{array}{ccccc}
 ST^2 & \xrightarrow{\lambda^T} & TST & \xrightarrow{T\lambda} & T^2S \\
 S\mu^T \downarrow & & & & \downarrow \mu^T S \\
 ST & \xrightarrow{\lambda} & & & TS
 \end{array}$$

The main theorem about distributive laws tells us about new monads that arise canonically as a result of the distributive law. In this work we will mostly be interested in the composite monad.

1.3. THEOREM. [Bec69] Write $S\text{-Alg}$ for the category of algebras for S , and $\text{Kl } T$ for the Kleisli category of T . The following are equivalent:

- A distributive law of S over T .
- A lifting of the monad T to a monad T' on $S\text{-Alg}$.
- An extension of the monad S to a monad \tilde{S} on $\text{Kl } T$.

It follows that TS canonically acquires the structure of a monad, whose category of algebras coincides with that of the lifted monad T' , and whose Kleisli category coincides with that of \tilde{S} .

For the proof we refer the reader to [Bec69]. Note that the theorem also holds more generally inside any 2-category with enough limits [Str72] so in particular holds in the 2-category 2-Cat of (small) 2-categories, strict 2-functors, and strict transformations.

1.4. EXAMPLE. (**Rings**)

- $\mathcal{C} = \text{Set}$
- $S = \text{free monoid monad}$
- $T = \text{free abelian group monad}$
- $\lambda = \text{the usual distributive law for multiplication and addition e.g.}$

$$(a + b)(c + d) \mapsto ac + bc + ad + bd.$$

Then the composite monad TS is the free ring monad.

1.5. EXAMPLE. (**2-categories**)

- $\mathcal{C} = 2\text{-GSet}$, the category of 2-globular sets.
- $S = \text{monad for vertical composition of 2-cells (1- and 0-cells are unchanged)}$
- $T = \text{monad for horizontal composition of 2-cells and 1-cells (0-cells are unchanged)}$

- λ is given by the interchange law, for example:

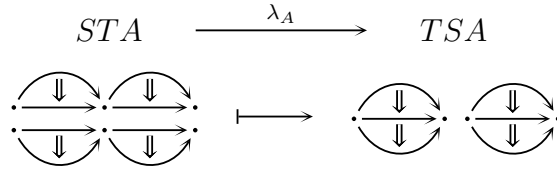

Note that these are pasting diagrams of composable 2-cells in the 2-globular set A , but we have not included the labels for the cells. The 2-cells of STA are given by vertical pastings of horizontal pastings of 2-cells of A ; the 2-cells of TSA are given by horizontal pastings of vertical pastings of 2-cells of A ; the above diagram indicates one particular 2-cell of STA , and the 2-cell of TSA it is sent to by λ_A .

This is all we need about distributive laws for this section; in Section 2 we will revisit distributive laws to examine more closely how to express TS -algebra structures via T - and S -algebra structures interacting.

1.6. THE DISTRIBUTIVE LAW IN THE 1-DIMENSIONAL SETTING. We will now lay out the 1-dimensional version of the distributive law for operadic weak n -categories; see [Che11a, CL19] for full details. This is a higher level of generality than we need in this work, but we choose to work at this level as it can then also be used for Trimble 3-categories, which we will study in a sequel. So we will parametrise all our composition by the action of operads. When composition is strict it will simply be the terminal operad.

The 1-dimensional distributive law in question is given in [CL19]; it is a slight generalisation of the version in [Che11a], which is itself a generalisation of the one given by Leinster for n -categories in [Lei04]. Rather than simply stating the results in full generality here, we will unravel them a little for the case that we need, in order to elucidate some of the subsequent constructions.

Our basic setup is an iterative operadic theory of n -categories, a generalisation of Trimble’s definition [Tri99] given in [Che11a]. The iteration is by “operadic enrichment”, where we form categories enriched in \mathcal{V} with composition parametrised by an operad P in \mathcal{V} .

1.7. DEFINITION. Let \mathcal{V} be a category with finite products, and P an operad in it. A (small) (\mathcal{V}, P) -category A is given by:

- an underlying \mathcal{V} -graph, that is, a set A_0 of objects and for all $a, b \in A_0$ a hom-object $A(a, b) \in \mathcal{V}$.
- For all $k \geq 0$ and $a_0, \dots, a_k \in A_0$ a composition morphism

$$P(k) \times A(a_{k-1}, a_k) \times \dots \times A(a_0, a_1) \longrightarrow A(a_0, a_k)$$

compatible with the composition and identities of the operad in the usual way (as for algebras). Morphisms are defined in the obvious way, giving a category $(\mathcal{V}, P)\text{-Cat}$, which also has products. We will also write this category $\mathcal{V}\text{-Cat}_P$, to facilitate the notation for iteration. Note that the category of \mathcal{V} -graphs and their morphisms will be denoted $\mathcal{V}\text{-Gph}$.

1.8. DEFINITION. An iterative operadic theory of n -categories is a series (\mathcal{V}_n, P_n) for $n \geq 0$, where each \mathcal{V}_n is a category with finite products and each P_n is an operad in \mathcal{V}_n , with

$$\mathcal{V}_{n+1} = \mathcal{V}_n\text{-Cat}_{P_n}$$

for every $n \geq 0$. Then \mathcal{V}_n is the category of n -categories and strict functors, according to this theory.

1.9. REMARK. Note that for each $n \geq 1$ a \mathcal{V}_n -category is a $(\mathcal{V}_{n-1}, P_{n-1})$ -category. We generally refer to composition along bounding k -cells as k -composition, but we also refer to 0-composition as horizontal and 1-composition as vertical. As explained in [Che11a], in an n -category, 0-composition is parametrised by P_{n-1} , and 1-composition by P_{n-2} .

In this work we will start this induction with $\mathcal{V}_0 = \mathbf{Set}$ and $P_0 = 1$ and thus $\mathcal{V}_1 = \mathbf{Cat}$. We then have

- an operad $P_1 \in \mathbf{Cat}$, and $\mathcal{V}_2 = \mathcal{V}_1\text{-Cat}_{P_1}$
- an operad $P_2 \in \mathcal{V}_2$, and $\mathcal{V}_3 = \mathcal{V}_2\text{-Cat}_{P_2} = \mathcal{V}_1\text{-Cat}_{P_1}\text{-Cat}_{P_2}$

One convenient aspect of this form of definition is that many results about strict iterated enrichment generalise straightforwardly, with just some notational complication as we must put operad actions everywhere. The first step is the free category construction.

In this work we will always be enriching with respect to the cartesian monoidal structure. To make the free category construction we also invoke small coproducts, and the products must distribute over them; we call this an “infinitely distributive” category. Shulman [Shu12] works with general monoidal structures and so uses the terminology “ \otimes -distributive categories”. The following result is from [Che11a, CL19], and gives us the general free (\mathcal{V}, P) -category monad we need. Elsewhere this monad is written as $\mathbf{fc}_{(\mathcal{V}, P)}$, but we will write it as \mathbf{fc}_P to streamline the subscripts. Note that if \mathcal{V} is infinitely distributive, then $\mathcal{V}\text{-Gph}$ is also [CL19].

1.10. PROPOSITION. [CL19] *Given any infinitely distributive category \mathcal{V} and operad P in it, $\mathcal{V}\text{-Cat}_P$ is monadic over $\mathcal{V}\text{-Gph}$ via a monad \mathbf{fc}_P , and the category $\mathcal{V}\text{-Cat}_P$ is in turn infinitely distributive.*

So we know that \mathcal{V}_3 is monadic over $\mathcal{V}_2\text{-Gph}$, and that \mathcal{V}_2 is monadic over $\mathcal{V}_1\text{-Gph}$; our aim now is to show that \mathcal{V}_3 is monadic over $\mathcal{V}_1\text{-Gph-Gph}$, and construct the monad as a composite via a distributive law. The idea is that if we think of \mathcal{V}_3 as $\mathcal{V}_1\text{-Cat}_{P_1}\text{-Cat}_{P_2}$ we can do a free category construction on the middle component (with the P_1 subscript) and on the last component (with the P_2 subscript) separately. The middle one constructs 1-composites (vertical) and the last one constructs 0-composites (horizontal). In the following diagram, the lower two forgetful functors produce our two monads for the distributive law. This is an instance of the square in [CL19, Prop 8.6].

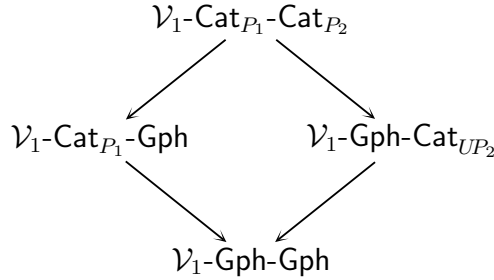

In order to construct the monad for 1-composition we use the following 2-functor.

1.11. DEFINITION. *The assignation $\mathcal{V} \mapsto \mathcal{V}\text{-Gph}$ extends to a 2-functor*

$$\underline{\text{Cat}} \longrightarrow \underline{\text{Cat}}$$

We write the action on functors as $()_$, so given a functor $\mathcal{V} \xrightarrow{F} \mathcal{W}$ we induce a functor $\mathcal{V}\text{-Gph} \xrightarrow{F_*} \mathcal{W}\text{-Gph}$ in the obvious way; likewise for natural transformations. Thus a monad T on \mathcal{V} induces a monad T_* on $\mathcal{V}\text{-Gph}$.*

1.12. REMARK. Note that T_* acts on a \mathcal{V} -graph by leaving the objects unchanged, and just acting as T on the homs.

1.13. DEFINITION. [Monad for vertical composition]

We know that $\mathcal{V}_2 = \mathcal{V}_1\text{-Cat}_{P_1}$ is monadic over $\mathcal{V}_1\text{-Gph}$ with monad fc_{P_1} . Write $T_1 = (\text{fc}_{P_1})_$ for the induced monad on $\mathcal{V}_1\text{-Gph-Gph}$, with $T_1\text{-Alg} \cong \mathcal{V}_2\text{-Gph}$.*

1.14. REMARK. The monad T_1 acts on a $\mathcal{V}_1\text{-Gph}$ -graph by leaving the 0-cells unchanged and then forming the free (\mathcal{V}_1, P_1) -category on each hom \mathcal{V}_1 -graph, that is, it makes vertical composition freely.

Next we construct the monad for horizontal composition. This comes from the monad for free (\mathcal{V}_2, P_2) -categories, but that monad already encodes interaction with vertical composition. So we invoke the forgetful functor $\mathcal{V}_2 \longrightarrow \mathcal{V}_1\text{-Gph}$ to forget that part, so that the monads for horizontal and vertical composition can be applied separately; the interaction will be encoded in the distributive law.

1.15. DEFINITION. [Monad for horizontal composition] *We know that \mathcal{V}_3 is monadic over $\mathcal{V}_2\text{-Gph} = \mathcal{V}_1\text{-Cat}_{P_1}\text{-Gph}$. We also have a forgetful functor*

$$\mathcal{V}_2 = \mathcal{V}_1\text{-Cat}_{P_1} \xrightarrow{U} \mathcal{V}_1\text{-Gph}.$$

As U preserves products, the operad $P_2 \in \mathcal{V}_2$ becomes an operad $UP_2 \in \mathcal{V}_1\text{-Gph}$, and we can form $(\mathcal{V}_1\text{-Gph}, UP_2)$ -categories. Then by Proposition 1.10 we know that $\mathcal{V}_1\text{-Gph-Cat}_{UP_2}$ is monadic over $\mathcal{V}_1\text{-Gph-Gph}$ with monad fc_{UP_2} . Call this monad T_0 .

Note that as we are enriching with respect to strict functors, we have strict interchange between vertical and horizontal composition, parametrised by actions of the operads in question. In this case, vertical composition is parametrised by P_1 and horizontal composition is parametrised by P_2 . Furthermore, note that as P_2 is an operad in $\mathcal{V}_1\text{-Cat}_{P_1}$ there

is also an action of P_1 on P_2 , that is, each $P_2(k)$ is a (\mathcal{V}_1, P_1) -category so has composition parametrised by an action of P_1 ; this has to be invoked when performing parametrised interchange (see [Che11a]). The following is an instance of [CL19, Prop 8.6].

1.16. PROPOSITION. *There is a distributive law $T_1T_0 \Longrightarrow T_0T_1$ with $T_0T_1\text{-Alg} \cong \mathcal{V}_3$ and the lifted monad \hat{T}_0 on $T_1\text{-Alg}$ is \mathbf{fc}_{P_2} .*

1.17. REMARK. The monad for 3-categories can be decomposed further by also invoking the monad for composition along bounding 2-cells. However, as we do not need to weaken this composition, we do not need to reference this monad.

Note that for this work we will be taking P_1 to be the operad for bicategories, that is, the free operad generated by one binary and one nullary operation. We will take $P_2 = 1$ (the terminal operad in \mathbf{Cat}) so that horizontal composition is strict.

1.18. THE 2-CATEGORY TOTALITIES. We now construct the iconic 2-category totalities we will be working with. Icons were introduced by Lack [Lac10], giving a convenient 2-dimensional totality of bicategories, and were iterated in [GG09] to give a convenient 2-dimensional totality of tricategories. Regarding bicategories as weak \mathbf{Cat} -categories, the definition of icon can be generalised to weak K -categories for bicategories K other than \mathbf{Cat} , yielding an iconic bicategory of weak K -categories. Under some mild conditions the generalised construction can then be iterated [CG14]. For this work we generalise in a slightly different direction, as we need to add in the action of an operad but we do not need K to be weak. As a result, we have strict 2-category totalities at every stage of the iteration, which we see as a great advantage of this operadic approach.

We will begin with the basic definitions, before introducing the operad actions.

1.19. DEFINITION. *Let K be a 2-category. Then a K -graph X is given by*

- a set X_0 of 0-cells, and
- for all $a, b \in X_0$ a hom-object $X(a, b)$ which is a 0-cell of K .

A morphism $X \xrightarrow{F} Y$ of K -graphs is given by

- a function $X_0 \xrightarrow{F_0} Y_0$, and
- for all $a, b \in X_0$ a 1-cell $X(a, b) \xrightarrow{F_{ab}} Y(Fa, Fb) \in K$.

Given morphisms $F, G: X \rightarrow Y$ of K -graphs, a transformation $\alpha: F \Longrightarrow G$ can exist only when F and G agree on 0-cells. In that case such a transformation is given by

- for all $a, b \in X_0$ a 2-cell in K as below:

$$\begin{array}{ccc}
 & F & \\
 & \curvearrowright & \\
 X(a, b) & & Y(Fa, Fb) \\
 & \alpha_{ab} \Downarrow & \\
 & & Y(Ga, Gb) \\
 & \curvearrowleft & \\
 & G &
 \end{array}$$

K -graphs, their morphisms and their 2-morphisms assemble into a 2-category $\underline{K\text{-Gph}}$, where the composition and identities are inherited from K .

1.20. **REMARK.** Note that if the underlying 1-category of K is denoted by K_1 , then a K -graph is no different from a K_1 -graph; likewise morphisms between them. The only difference is that the 2-cells of K enable us to put a 2-dimensional structure on the totality. That is, the underlying 1-category of $\underline{K\text{-Gph}}$ is the same as the 1-category $K_1\text{-Gph}$.

In what follows K could be a tensor distributive monoidal 2-category as in [Shu12]. However in all our cases we will use products, so we need K to have small coproducts, and finite products that distribute over them (using the strictest 2-dimensional version of (co)limits); we will call such a 2-category “infinitely distributive”. The definition of K -icon is given in [CG14] in a fully weak setting using monoidal bicategories; our setting is simplified by us using strict enrichment in a strict 2-category, and strict functors.

As with K -graphs, the concepts of K -category and K -functor are no different from K_1 -category and K_1 -functor; the difference is that we now have 2-dimensional structure with which to assemble K -categories into a 2-category.

1.21. **DEFINITION.** Let K be a 2-category with products. Then a category enriched in K is just a category enriched in its underlying 1-category K_1 , and a K -functor is just a K_1 -functor.

1.22. **DEFINITION.** [K -icons]

Let X, Y be K -categories, and let $F, G: X \rightarrow Y$ be strict K -functors such that $Fa = Ga$ for all objects $a \in X$. A **K -icon**

$$\begin{array}{ccc} & F & \\ X & \begin{array}{c} \curvearrowright \\ \Downarrow \alpha \\ \curvearrowleft \end{array} & Y \\ & G & \end{array}$$

is given by, for all pairs of objects $a, b \in X$ a 2-cell

$$\begin{array}{ccc} & F & \\ X(a, b) & \begin{array}{c} \curvearrowright \\ \alpha_{ab} \Downarrow \\ \curvearrowleft \end{array} & \begin{array}{c} Y(Fa, Fb) \\ Y(Ga, Gb) \end{array} \\ & G & \end{array}$$

satisfying the following axioms. Note that the following are all diagrams in K . We write (a, b) for the hom-object of the appropriate K -category, and omit \times signs. Here m and m' represent composition in the appropriate K -categories.

- *Composition:*

$$\begin{array}{ccc}
 \begin{array}{c}
 \begin{array}{ccc}
 (b, c)(a, b) & \xrightarrow{FF} & (Fb, Fc)(Fa, Fb) \\
 \downarrow m & \searrow \alpha \Downarrow & \parallel \\
 (a, c) & \xrightarrow{GG} & (Gb, Gc)(Ga, Gb) \\
 \downarrow m' & \swarrow \parallel & \downarrow m' \\
 (a, c) & \xrightarrow{G} & (Ga, Gc)
 \end{array} \\
 \parallel \\
 \begin{array}{ccc}
 (b, c)(a, b) & \xrightarrow{FF} & (Fb, Fc)(Fa, Fb) \\
 \downarrow m & \searrow \parallel & \downarrow m' \\
 (a, c) & \xrightarrow{F} & (Fa, Fc) \\
 \downarrow \alpha \Downarrow & \swarrow \parallel & \downarrow \\
 (a, c) & \xrightarrow{G} & (Ga, Gc)
 \end{array}
 \end{array}
 \end{array}
 =
 \begin{array}{ccc}
 \begin{array}{ccc}
 (b, c)(a, b) & \xrightarrow{FF} & (Fb, Fc)(Fa, Fb) \\
 \downarrow m & \searrow \parallel & \downarrow m' \\
 (a, c) & \xrightarrow{F} & (Fa, Fc) \\
 \downarrow \alpha \Downarrow & \swarrow \parallel & \downarrow \\
 (a, c) & \xrightarrow{G} & (Ga, Gc)
 \end{array}
 \end{array}$$

- *Unit:*

$$\begin{array}{ccc}
 \begin{array}{ccc}
 \mathbb{1} & \xrightarrow{I} & (a, a) \\
 & \searrow \parallel & \parallel \\
 \mathbb{1} & \xrightarrow{I'} & (Fa, Fa) = (Ga, Ga) \\
 & \swarrow \parallel & \parallel \\
 \mathbb{1} & \xrightarrow{I} & (a, a) \\
 & \searrow \parallel & \parallel \\
 \mathbb{1} & \xrightarrow{I'} & (Fa, Fa) = (Ga, Ga)
 \end{array}
 \end{array}
 =
 \begin{array}{ccc}
 \begin{array}{ccc}
 \mathbb{1} & \xrightarrow{I} & (a, a) \\
 & \searrow \parallel & \parallel \\
 \mathbb{1} & \xrightarrow{I'} & (Fa, Fa) = (Ga, Ga) \\
 & \swarrow \parallel & \parallel \\
 \mathbb{1} & \xrightarrow{I} & (a, a) \\
 & \searrow \parallel & \parallel \\
 \mathbb{1} & \xrightarrow{I'} & (Fa, Fa) = (Ga, Ga)
 \end{array}
 \end{array}$$

Write $\underline{K}\text{-Cat}$ for the 2-category of K -categories, K -functors, and K -icons.

1.23. REMARK. This is more usually written $\underline{K}\text{-Icon}$ to distinguish it from the full 3-dimensional totality of K -categories, but we will write it as $\underline{K}\text{-Cat}$ as there will be no ambiguity, and we want to emphasise the K -categories as they are our main objects of study.

We now need to weaken all this by the action of an operad. As we are working somewhat strictly we do not need to invoke any 2-categorical structure for the operad. So an operad in a 2-category K is just an operad in the underlying 1-category K_1 .

1.24. DEFINITION. Let K be a 2-category with products, and P an operad in K . We define a 2-category $\underline{K}\text{-Cat}_P$ as follows.

- 0-cells are (K, P) -categories i.e. (K_1, P) -categories
- 1-cells are (strict) (K, P) -functors
- 2-cells are (K, P) -icons.

Note that the underlying data for a (K, P) -icon is the same as for a K -icon, but the composition axiom is now parametrised by P as follows (where m and m' now represent parametrised composition in the appropriate (K, P) -category):

$$\begin{array}{ccc}
 & \xrightarrow{1 \times F^k} & \\
 P(k)(x_{k-1}, x_k) \cdots (x_0, x_1) & \Downarrow 1 \times \alpha^k & P(k)(Fx_{k-1}, Fx_k) \cdots (Fx_0, Fx_1) \\
 & \xrightarrow{1 \times G^k} & P(k)(Gx_{k-1}, Gx_k) \cdots (Gx_0, Gx_1) \\
 \downarrow m & & \downarrow m' \\
 (x_0, x_k) & \cong & (Gx_0, Gx_k) \\
 & \xrightarrow{G} & \\
 & \xrightarrow{1 \times F^k} & \\
 P(k)(x_{k-1}, x_k) \cdots (x_0, x_1) & & P(k)(Fx_{k-1}, Fx_k) \cdots (Fx_0, Fx_1) \\
 \downarrow m & \cong & \downarrow m' \\
 (x_0, x_k) & \xrightarrow{F} & (Fx_0, Fx_k) \\
 & \alpha \Downarrow & \cong \\
 & \xrightarrow{G} & (Gx_0, Gx_k)
 \end{array} =$$

Horizontal and vertical composition of (K, P) -icons are built in the obvious way from horizontal and vertical composition of 2-cells in K , and it is straightforward to check that these composites satisfy the operadic composition condition.

The 2-category axioms for $\underline{\underline{K\text{-Cat}_P}}$ are inherited from K .

Note that from this point on, we will be working entirely 2-categorically so we will drop the double underline notation on 2-categories as there should be no ambiguity. We can now iterate all the constructions so we have 2-categories as follows:

- $\mathcal{V}_1 = \text{Cat}$ (here the 2-cells are ordinary natural transformations),
- $\mathcal{V}_2 = \mathcal{V}_1\text{-Cat}_{P_1}$ with iconic 2-cells, and
- $\mathcal{V}_3 = \mathcal{V}_2\text{-Cat}_{P_2}$ with iconic 2-cells.

1.25. EXTENDING THE DISTRIBUTIVE LAW TO THE 2-CATEGORY TOTALITIES. We will now extend the 1-dimensional distributive law to the 2-category totalities. Parts of this have to some extent been done already: Lack and Paoli [LP08] study the distributive law at the 2-monad level for bicategories, and Shulman [Shu12] studies it in some generality for both strict and weak algebras. However we need a different combination of strictness and weakness here, as we need our monads to be for weak vertical composition but strict horizontal composition. Bicategories are often treated as weak algebras for the strict 2-category monad, for example in [Shu12], but we want all our algebras to be strict. That is, we express bicategories as strict algebras for a monad for bicategories, rather than as weak algebras for a monad for 2-categories.

As we already know the results are true for the underlying 1-monads on the underlying 1-categories, we just have to check the information at the 2-dimensional level. This is mostly a question of working out what needs to be checked; the calculations are then straightforward. This could also be seen as a generalisation of [Shu12] to include operad actions, but we have decided to include the direct calculations, partly as they are not hard and partly as we found them illuminating.

1.26. PROPOSITION. [2-categorical version of Prop 1.10]

Given any infinitely distributive 2-category K and an operad P in it, the 2-category $K\text{-Cat}_P$ is 2-monadic over $K\text{-Gph}$ via a 2-monad \mathbf{fc}_P , whose underlying 1-monad is the one given in Proposition 1.10. Furthermore, $K\text{-Cat}_P$ is also infinitely distributive.

PROOF. Write T for the monad \mathbf{fc}_P , with unit η and multiplication μ . First we need to extend the 1-monad as follows

1. make the underlying functor into a 2-functor, i.e., give its action on iconic 2-cells, and
2. make η and μ into 2-transformations, i.e., check the cylinder conditions.

For (1) we know the action of $T K\text{-Gph} \rightarrow K\text{-Gph}$ on 0-cells and 1-cells. On 0-cells, given a K -graph A , TA has the same objects, and

$$TA(a, a') = \coprod_{k, a=a_0, a_1, \dots, a_k=a'} P(k) \times A(a_{k-1}, a_k) \times \dots \times A(a_0, a_1)$$

That is, essentially, composable strings equipped with a reparametrising operation. The action of T on 1-cells is pointwise: given a morphism $A \xrightarrow{F} B$ of K -graphs, the morphism $TA \xrightarrow{TF} TB$ has the same action on objects, and on homs the action is as shown below.

$$\begin{array}{c} P(k) \times A(a_{k-1}, a_k) \times \dots \times A(a_0, a_1) \\ \downarrow 1 \times F^k \\ P(k) \times B(Fa_{k-1}, Fa_k) \times \dots \times B(Fa_0, Fa_1) \end{array}$$

We can now define the action of T on 2-cells to be pointwise as well. So consider morphisms of K -graphs

$$X \begin{array}{c} \xrightarrow{F} \\ \xrightarrow{G} \end{array} Y$$

agreeing on objects, and a 2-cell α given as below, for all a, b .

$$\begin{array}{ccc} & F & \\ & \curvearrowright & \\ X(a, b) & \alpha_{ab} \Downarrow & Y(Fa, Fb) \\ & & \parallel \\ & & Y(Ga, Gb) \\ & \curvearrowleft & \\ & G & \end{array}$$

Then TF and TG also agree on objects and we define an icon $T\alpha : TF \Longrightarrow TG$ by the following (where in this diagram we omit the subscripts on the components of α so that α^k represents $\alpha_{x_{k-1}x_k} \cdots \alpha_{x_0x_1}$).

$$\begin{array}{ccc}
 & \xrightarrow{TF = 1 \times F^k} & \\
 P(k)(x_{k-1}, x_k)(x_0, x_1) & \Downarrow 1 \times \alpha^k & P(k)(Fx_{k-1}, Fx_k)(Fx_0, Fx_1) \\
 & & \parallel \\
 & & P(k)(Gx_{k-1}, Gx_k)(Gx_0, Gx_1) \\
 & \xrightarrow{TG = 1 \times G^k} &
 \end{array}$$

For (2) there is no extra data for η and μ , we just have to check the 2-dimensional cylinder conditions. We have to check that the following diagram commutes (as a diagram in K):

$$\begin{array}{ccc}
 (a, b) \xrightarrow{\eta} P(1)(a, b) & & \\
 \left. \begin{array}{c} \text{\scriptsize } F \\ \text{\scriptsize } \Downarrow \\ \text{\scriptsize } \alpha \\ \text{\scriptsize } \Uparrow \\ \text{\scriptsize } G \end{array} \right\} & \cong & \left. \begin{array}{c} \text{\scriptsize } 1 \times G \\ \text{\scriptsize } \Downarrow \\ \text{\scriptsize } 1 \times \alpha \\ \text{\scriptsize } \Uparrow \\ \text{\scriptsize } G \end{array} \right\} \\
 (Fa, Fb) = (Ga, Gb) \xrightarrow{\eta} P(1)(Ga, Gb) & & \\
 \\
 (a, b) \xrightarrow{\eta} P(1)(a, b) & & \\
 \left. \begin{array}{c} \text{\scriptsize } F \\ \text{\scriptsize } \Downarrow \\ \text{\scriptsize } 1 \times \alpha \\ \text{\scriptsize } \Uparrow \\ \text{\scriptsize } 1 \times G \end{array} \right\} & \cong & \left. \begin{array}{c} \text{\scriptsize } 1 \times F \\ \text{\scriptsize } \Downarrow \\ \text{\scriptsize } 1 \times \alpha \\ \text{\scriptsize } \Uparrow \\ \text{\scriptsize } 1 \times G \end{array} \right\} \\
 (Fa, Fb) \xrightarrow{\eta} P(1)(Fa, Fb) = P(1)(Ga, Gb) & &
 \end{array}$$

To see that this commutes, note that η acts as the identity on objects, and on hom objects the action is via the unit of the operad P as follows:

$$(a, b) \cong 1 \times (a, b) \xrightarrow{\text{unit} \times 1} P(1) \times (a, b) \subset TA.$$

So the η and α parts of the diagram act on different parts of the product, and the above cylinder diagram does indeed commute.

We now turn our attention to μ . We know that μ acts by concatenation together with composition of the operad P . We need to check the following diagram:

$$\begin{array}{ccc}
 T^2(a, b) & \xrightarrow{\mu} & T(a, b) \\
 \left. \begin{array}{c} \text{\scriptsize } T^2F \\ \text{\scriptsize } \Downarrow \\ \text{\scriptsize } T^2\alpha \\ \text{\scriptsize } \Downarrow \\ \text{\scriptsize } T^2G \end{array} \right\} & \text{\scriptsize } \cong & \left. \begin{array}{c} \text{\scriptsize } TG \\ \text{\scriptsize } \Downarrow \\ \text{\scriptsize } T(Ga, Gb) \end{array} \right\} \\
 T^2(Fa, Fb) = T^2(Ga, Gb) & \xrightarrow{\mu} & T(Ga, Gb)
 \end{array} =$$

$$\begin{array}{ccc}
 T^2(a, b) & \xrightarrow{\mu} & T(a, b) \\
 \left. \begin{array}{c} \text{\scriptsize } T^2F \\ \text{\scriptsize } \Downarrow \\ \text{\scriptsize } T^2(Fa, Fb) \end{array} \right\} & \text{\scriptsize } \cong & \left. \begin{array}{c} \text{\scriptsize } TF \\ \text{\scriptsize } \Downarrow \\ \text{\scriptsize } T\alpha \\ \text{\scriptsize } \Downarrow \\ \text{\scriptsize } TG \end{array} \right\} \\
 T^2(Fa, Fb) & \xrightarrow{\mu} & T(Fa, Fb) = T(Ga, Gb)
 \end{array}$$

Since $T^2\alpha$ and $T\alpha$ both act pointwise, this commutes.

So we have a 2-monad \mathbf{fc}_P as claimed.

Next we need to establish an equivalence of 2-categories

$$T\text{-Alg} \simeq K\text{-Cat}_P.$$

In fact, as in the 1-dimensional case, this is an isomorphism because (K, P) -categories are precisely algebras for the monad T . (We could have defined the monad T first, and then defined (K, P) -categories to be T -algebras.) The 1-cell correspondence works as in the 1-dimensional case, so we just need to examine iconic 2-cells. A 2-cell α of T -algebras is a 2-cell of K satisfying the additional cylinder condition:

$$\begin{array}{ccc}
 \begin{array}{ccc}
 TA & \xrightarrow{Tf} & TB \\
 \downarrow a & \text{\scriptsize } T\alpha \Downarrow & \downarrow b \\
 A & \xrightarrow{Tg} & B \\
 \downarrow & \text{\scriptsize } \cong & \downarrow \\
 A & \xrightarrow{g} & B
 \end{array} & = & \begin{array}{ccc}
 TA & \xrightarrow{Tf} & TB \\
 \downarrow a & \text{\scriptsize } \cong & \downarrow b \\
 A & \xrightarrow{f} & B \\
 \downarrow & \text{\scriptsize } \alpha \Downarrow & \downarrow \\
 A & \xrightarrow{g} & B
 \end{array}
 \end{array}$$

We see that this condition is exactly the cylinder condition for iconic 2-cells of $K\text{-Cat}_P$.

Finally note that infinite distributivity follows as for the 1-dimensional version, that is, since products and coproducts in $K\text{-Cat}_P$ are constructed from those in K . ■

We now use this general free (K, P) -category 2-monad to construct the two 2-monads which will be composed via a distributive law. In the 1-dimensional version, the monad for vertical composition comes from a 2-functor

$$\begin{array}{ccc}
 \mathbf{Cat} & \longrightarrow & \mathbf{Cat} \\
 \mathcal{V} & \longmapsto & \mathcal{V}\text{-Gph}
 \end{array}$$

We now need to use an analogous 2-functor

$$\begin{array}{ccc} 2\text{-Cat} & \longrightarrow & 2\text{-Cat} \\ K & \longmapsto & K\text{-Gph} \end{array}$$

As in the 1-dimensional version, a 2-functor

$$F : K \longrightarrow K'$$

is sent to the 2-functor

$$F_* : K\text{-Gph} \longrightarrow K'\text{-Gph}$$

which leaves objects unchanged, and applies F to the hom K -objects; the action on icons works similarly. The full definition of this 2-functor is given very succinctly in [Shu12, Section 3] where it is called \mathcal{G} . As in the 1-dimensional case, a 2-monad T on K induces a 2-monad T_* on $K\text{-Gph}$. T_* acts on a K -graph by leaving the objects unchanged and applying T to the hom K -objects; the unit and multiplication act on objects as the identity on objects, and at the level of hom objects as the unit and multiplication for T .

1.27. PROPOSITION. *Let T be a 2-monad on K with 2-category of algebras K^T . Then $\mathcal{G}T$ is a 2-monad on $\mathcal{G}K$ and $(\mathcal{G}K)^{(\mathcal{G}T)} \cong \mathcal{G}(K^T)$, that is*

$$T_*\text{-Alg} \cong (T\text{-Alg})\text{-Gph}.$$

PROOF. A T_* -algebra is a K -graph A together with an algebra action $T_*A \xrightarrow{\theta} A$ satisfying the usual algebra axioms. As T_* leaves the objects of A unchanged, the unit axiom for algebras ensures that the algebra action θ must be the identity on objects; the unit and associativity axioms at the level of homs tell us that θ gives a T -algebra action on each hom K -object. That is, we have a graph enriched in $T\text{-Alg}$.

A map of T_* -algebras is a 1-cell $A \xrightarrow{f} B$ of the underlying K -graphs such that the usual square commutes. As the algebra actions are the identity on objects, this gives us any function f on the underlying objects, and a T -algebra map at the level of homs. That is, we have a map of graphs enriched in $T\text{-Alg}$.

A 2-cell

$$\begin{array}{ccc} & f & \\ & \curvearrowright & \\ A & \Downarrow \alpha & B \\ & \curvearrowleft & \\ & g & \end{array}$$

between maps of T_* -algebras is a 2-cell of $K\text{-Gph}$ satisfying the cylinder condition. Thus it is an icon, so we start with the condition that f and g must agree on objects; the rest of the data and the axioms amount to a 2-cell between T -algebras at the level of homs. That is, we have an iconic 2-cell of $(T\text{-Alg})\text{-Gph}$. ■

The 2-monads for horizontal and vertical composition are then straightforward 2-dimensional extensions of Definitions 1.13 and 1.15.

We start with

- $\mathcal{V}_1 = \text{Cat}$ (here the 2-cells are ordinary natural transformations), and P_1 is an operad in \mathcal{V}_1
- $\mathcal{V}_2 = \mathcal{V}_1\text{-Cat}_{P_1}$ with iconic 2-cells, and P_2 is an operad in \mathcal{V}_2
- $\mathcal{V}_3 = \mathcal{V}_2\text{-Cat}_{P_2} = \mathcal{V}_1\text{-Cat}_{P_1}\text{-Cat}_{P_2}$ with iconic 2-cells.

The following diagram of categories and monadic forgetful functors (the lower part of the diagram after Proposition 1.10) becomes a diagram of 2-categories and 2-monadic forgetful 2-functors.

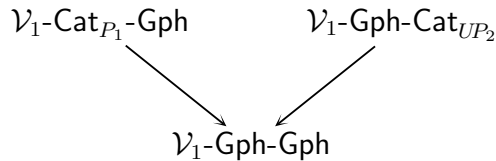

As in the 1-categorical case, we define the following 2-monads on $\mathcal{V}_1\text{-Gph-Gph}$

- For vertical composition: $S = (\text{fc}_{P_1})_*$.
- For horizontal composition: $T = \text{fc}_{UP_2}$.

Finally, we check that the distributive law from the 1-categorical case (Proposition 1.16)

$$ST \xrightarrow{\lambda} TS$$

extends to a 2-dimensional distributive law. We have to check that λ becomes a 2-transformation, that is, that the cylinder diagram commutes (as a diagram in $\mathcal{V}_1\text{-Gph-Gph}$):

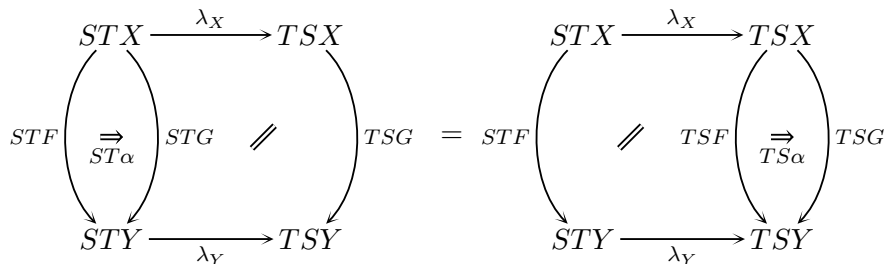

First note that a 2-cell of STX essentially consists of a composable grid of 2-cells of X , adorned with some appropriate operad elements for parametrising their formal composition, as shown below; here each b_i is a 1-cell of $P_2(w)$ that is considered to parametrise

the row of cells in question (as produced by T), and moreover as S produces vertical composites of cells of TX , we know that b_1, \dots, b_h are composable in $P_2(w)$, and a is a 0-cell of $P_1(h)$ which is here considered to parametrise the entire vertical composite.

$$a \left[\begin{array}{cccc} b_1 (x_{11} & x_{21} & \cdots & x_{w1}) \\ \vdots & & & \\ b_h (x_{1h} & x_{2h} & \cdots & x_{wh}) \end{array} \right]$$

The distributive law places this configuration inside TSX as shown below:

- each column of cells is now considered to be vertically parametrised by a , and each one is thus now a 2-cell of SX ,
- T produces horizontal composites of 2-cells of SX , parametrised by 1-cells of P_2 , and here the 1-cell in question is the composite of b_1, \dots, b_h parametrised by a

$$a \left(\begin{array}{c} b_1 \\ \vdots \\ b_h \end{array} \right) \left[a \left(\begin{array}{c} x_{11} \\ \vdots \\ x_{w1} \end{array} \right) \cdots a \left(\begin{array}{c} x_{1h} \\ \vdots \\ x_{wh} \end{array} \right) \right]$$

See [Che11a, Theorem 4.1] for the derivation of this distributive law.

Now we see that $ST\alpha$ acts as α pointwise on the individual cells of the grid, and leaves the operad elements unchanged. $TS\alpha$ does likewise, so the equation holds.

1.28. EXAMPLE: \mathbf{Bicat}_s -CATEGORIES. For this work we use the following special case:

- We set $\mathcal{V}_1 = \mathbf{Cat}$ and $P_1 =$ the operad for bicategories (the free contractible operad on one binary and one nullary operation).
- Then by definition $\mathcal{V}_2 := \mathcal{V}_1\text{-Cat}_{P_1} = \mathbf{Bicat}_s$.
- We set $P_2 = 1$ (the terminal operad).
- Then by definition $\mathcal{V}_3 := (\mathbf{Bicat}_s, 1)\text{-Cat} = \mathbf{Bicat}_s\text{-Cat}$.

We then have the following 2-monads on $\mathbf{Cat}\text{-Gph}\text{-Gph}$:

- for (strict) horizontal composition: $H = \mathbf{fc}_{UP_2}$,
- for (weak) vertical composition: $V = (\mathbf{fc}_{P_1})_*$,

Note that the algebras for H are $\mathbf{Cat}\text{-Gph}$ -categories, and the algebras for V are \mathbf{Bicat}_s -graphs.

We have a 2-dimensional distributive law

$$VH \implies HV$$

thus by Proposition 1.16 we know that H lifts to a 2-monad H' on $\mathcal{V}\text{-Alg} = \mathbf{Bicat}_s\text{-Gph}$ and this lifted monad is the free \mathbf{Bicat}_s -category monad. Thus by Beck's theorem (inside 2-Cat) we know

$$HV\text{-Alg} \cong \mathbf{Bicat}_s\text{-Cat}$$

showing that the 2-category of \mathbf{Bicat}_s -categories with iconic 2-cells can be constructed as the 2-category of algebras for the composite 2-monad HV . This is the construction we will use to define weak maps between \mathbf{Bicat}_s -categories in the next section.

Note that the underlying data for an HV -algebra is a $\mathbf{Cat}\text{-Gph}$ -graph, that is, it has 0-cells, 1-cells, and hom-categories of 2-cells and 3-cells. Doubly-degenerate \mathbf{Bicat}_s -categories can then be constructed as doubly-degenerate HV -algebras, that is, HV -algebras whose underlying $\mathbf{Cat}\text{-Gph}$ -graph has only one 0-cell and only one 1-cell. We perform the usual "dimension shift" and disregard the single 0-cell and single 1-cell, so that the underlying data becomes just a category.

2. Algebras via distributive laws

In this section we will give more details about how to use 2-dimensional distributive laws to study weak maps between TS -algebras in general. This will enable us to define weak maps of \mathbf{Bicat}_s -categories via weak maps of algebras for the individual 2-monads. These are only weak enough in the doubly-degenerate case because, in effect, they force (or assume) strict functoriality on 1-cells. For general tricategories this is too strict, but for doubly-degenerate ones there is only one 0-cell and only one 1-cell so weak functors are trivially strictly functorial on 1-cells.

As our motivating example is not a fully weakly 2-dimensional, we will simplify the situation by keeping it as strict as that example:

- strict 2-categories, strict 2-functors, strict transformations
- strict 2-monads and strict distributive laws between them
- strict algebras
- weak maps of algebras
- strict transformations of algebras

For this reason we will not just use the analogous results about pseudo distributive laws from [CHP04, Cor. 5.5] giving a biequivalence of bicategories

$$TS\text{-Alg} \simeq T'\text{-Alg}$$

where T' is a lifting of T to $S\text{-Alg}$. We have a much better behaved situation and we can characterise weak maps of TS -algebras precisely with a direct approach. Our goal is to achieve a convenient explicit description of weak maps of doubly-degenerate \mathbf{Bicat}_s -categories. We follow Kelly and Street [KS74] and consider strict 2-monads (which they

call doctrines), strict algebras, and weak maps of algebras (although their focus is more on the lax case). Keeping the 2-monads and the algebras strict makes for a much simpler theory, without us losing any of the expressivity we need.

We begin by giving a closer examination of algebras for a composite monad TS .

2.1. ALGEBRAS VIA DISTRIBUTIVE LAWS. The basic theorem about a distributive law of S over T (Theorem 1.3) shows that algebras for the composite monad TS are the same as algebras for the lifted monad T' . However, in practice we often express them as a T -algebra structure and an S -algebra structure satisfying an interaction axiom coming from the distributive law. This is one possible answer to the question of why a distributive law is called a “law” when it is a piece of extra structure on the monads (a natural transformation): it is a law at the level of algebra structures.

The following easy corollary makes this precise.

2.2. COROLLARY. [Bec69, Section 2] *Let S and T be monads on a category \mathcal{C} , and $\lambda :$*

$ST \implies TS$ a distributive law. Then a TS -algebra is equivalently a T -algebra $\begin{matrix} TA \\ \downarrow t \\ A \end{matrix}$ and S -algebra $\begin{matrix} SA \\ \downarrow s \\ A \end{matrix}$ such that the following diagram commutes:

$$\begin{array}{ccc}
 STA & \xrightarrow{st} & SA \\
 \lambda_A \downarrow & & \downarrow s \\
 TSA & & A \\
 Ts \downarrow & & \downarrow t \\
 TA & \xrightarrow{t} & A
 \end{array}$$

We follow Beck and call this a λ -distributive algebra pair, or λ -distributive pair for short, and will refer to this diagram as “ s/t interaction”.

We have included a proof in the Appendix, expressed in string diagrams, as we found it helpful for what follows.

2.3. REMARK. It will later be useful to have an explicit correspondence between TS -algebras and λ -distributive algebra pairs.

- Given a TS -algebra $\begin{pmatrix} TSA \\ \downarrow \theta \\ A \end{pmatrix}$ we get the pair $\begin{pmatrix} SA & TA \\ \downarrow \eta_{SA}^T & \downarrow T\eta_A^S \\ TSA & TSA \\ \downarrow \theta & \downarrow \theta \\ A & A \end{pmatrix}$.
- Given the pair $\begin{pmatrix} SA & TA \\ \downarrow s & \downarrow t \\ A & A \end{pmatrix}$ we get the TS -algebra $\begin{pmatrix} TSA \\ \downarrow Ts \\ TA \\ \downarrow t \\ A \end{pmatrix}$.

This follows from the above corollary and standard correspondence between T -algebras and T' -algebras.

2.4. EXAMPLES.

1. In the case of rings, the above correspondence expresses a ring as a set with a monoid structure and an abelian group structure satisfying distributivity of the monoid operation over the group operation, that is, the usual direct definition of a ring.
2. In the case of 2-categories, the above correspondence expresses a 2-category as a 2-globular set equipped with vertical and horizontal composition satisfying interchange, that is, one of the usual direct definitions of a 2-category.
3. We can modify the example of 2-categories to produce doubly-degenerate 2-categories. Let $\mathcal{C}, T, S, \lambda$ be as in Example 1.5. A doubly-degenerate TS -algebra is by definition a λ -distributive pair where the underlying 2-globular set is doubly-degenerate. That is, it has only one 0-cell and only one 1-cell, so is of the following form (as a diagram of sets and functions) and so its underlying data is just a set.

$$A_2 \rightrightarrows 1 \rightrightarrows 1$$

Thus a doubly-degenerate 2-category is a set equipped with two monoid structures, with one distributing over the other. The standard Eckmann–Hilton argument shows that these must be the same and commutative.

4. Finally, the correspondence tells us that a \mathbf{Bicat}_s -category is a $\mathbf{Cat}\text{-}\mathbf{Gph}$ -graph equipped with weak vertical composition and strict horizontal composition, satisfying strict interchange. Restricting to the doubly-degenerate ones, we see that a doubly-degenerate \mathbf{Bicat}_s -category is a doubly-degenerate $\mathbf{Cat}\text{-}\mathbf{Gph}$ -graph (that is, a category) equipped with a weak “vertical” tensor product and a strict “horizontal” tensor product, satisfying strict interchange.

2.5. **REMARK.** Doubly-degenerate 2-categories cannot be simply expressed by restricting T and S to a category of doubly degenerate 2-globular sets (i.e. \mathbf{Set}), as T does not restrict — even if A is a doubly degenerate 2-globular set, TA is not, as it creates formal composites of the unique 1-cell. The same is true for doubly-degenerate \mathbf{Bicat}_s -categories.

2.6. **MAPS OF ALGEBRAS VIA DISTRIBUTIVE LAWS.** We now move on to consider maps of algebras via distributive laws. Just as we can express TS -algebras in terms of a T -algebra and an S -algebra (in the presence of a distributive law of S over T), we can express maps of TS -algebras as a map of T -algebras and a map of S -algebras.

2.7. **THEOREM.** *In the presence of a distributive law of monads S over T , a map f of TS -algebras is precisely a map f which is a map of both the associated T -algebra and the associated S -algebra.*

PROOF. Consider TS -algebras $TSA \xrightarrow{\theta} A$ and $TSB \xrightarrow{\phi} B$ and a map $A \xrightarrow{f} B$ between them, so the following diagram commutes.

$$\begin{array}{ccc} TSA & \xrightarrow{TSf} & TSB \\ \theta \downarrow & & \downarrow \phi \\ A & \xrightarrow{f} & B \end{array}$$

We need to check that f is a map of the associated T -algebras and of the associated S -algebras. This is seen from the following diagrams where the top squares are naturality squares:

$$\begin{array}{ccc} SA & \xrightarrow{Sf} & SB \\ \eta_{SA}^T \downarrow & & \downarrow \eta_{SB}^T \\ TSA & \xrightarrow{TSf} & TSB \\ \theta_A \downarrow & & \downarrow \theta_B \\ A & \xrightarrow{f} & B \end{array} \quad \begin{array}{ccc} TA & \xrightarrow{Tf} & TB \\ T\eta_A^S \downarrow & & \downarrow T\eta_B^S \\ TSA & \xrightarrow{TSf} & TSB \\ \theta_A \downarrow & & \downarrow \theta_B \\ A & \xrightarrow{f} & B \end{array}$$

Conversely, suppose we know that f is a map of the associated T -algebra and S -algebra structures given by the λ -distributive pairs below.

$$\left(\begin{array}{cc} TA & SA \\ \downarrow a_t & \downarrow a_s \\ A & A \end{array} \right) \quad \text{and} \quad \left(\begin{array}{cc} TB & SB \\ \downarrow b_t & \downarrow b_s \\ B & B \end{array} \right)$$

We check that f satisfies the axioms for a map of TS -algebras. This is seen from the following diagram, where by definition the left-hand map is θ and the right-hand map is ϕ , and the squares are the axioms for a T -algebra map and an S -algebra map respectively:

$$\begin{array}{ccc} TSA & \xrightarrow{TSf} & TSB \\ Ta_s \downarrow & & \downarrow Tb_s \\ TA & \xrightarrow{Tf} & TB \\ a_t \downarrow & & \downarrow b_t \\ A & \xrightarrow{f} & B \end{array}$$

■

2.8. EXAMPLES.

1. A ring homomorphism consists of a map that is both a group homomorphism and a monoid homomorphism.
2. A functor of 2-categories is a map of the underlying 2-globular sets that respects both the horizontal composition and the vertical composition. This has a slightly different emphasis from the expression as a T' -algebra map, which says it is a functor on hom-categories and a Cat -enriched functor as well.

We now move to the case of weak maps of algebras.

2.9. WEAK MAPS OF ALGEBRAS VIA DISTRIBUTIVE LAWS. We now extend the 1-categorical results to a 2-categorical framework. Since we are dealing with strict 2-monads, strict algebras and strict distributive laws throughout this work, the previous theorems characterising TS -algebras still hold. However, we need a new result characterising weak maps of TS -algebras. First we recall the definition of a weak map of algebras for a 2-monad T .

2.10. DEFINITION. *Let T be a 2-monad on a 2-category \mathcal{C} . Given strict algebras $TA \xrightarrow{a} A$ and $TB \xrightarrow{b} B$ a weak map between them is given by a 1-cell $A \xrightarrow{f} B$ and a 2-cell isomorphism*

$$\begin{array}{ccc} TA & \xrightarrow{Tf} & TB \\ a \downarrow & \tau \Downarrow \sim & \downarrow b \\ A & \xrightarrow{f} & B \end{array}$$

satisfying the following axioms.

$$\begin{array}{ccc} \begin{array}{ccccc} T^2A & \xrightarrow{T^2f} & T^2B & \xrightarrow{\mu_B} & TB \\ \mu_A \searrow & = & \searrow & & \\ TA & \xrightarrow{Tf} & TB & & \\ \downarrow Ta & \mu_A \searrow & \downarrow a & \Downarrow \tau & \downarrow b \\ TA & \xrightarrow{a} & A & \xrightarrow{f} & B \end{array} & = & \begin{array}{ccccc} T^2A & \xrightarrow{T^2f} & T^2B & \xrightarrow{\mu_B} & TB \\ \downarrow Ta & \Downarrow_{T\tau} & \downarrow Tb & & \\ TA & \xrightarrow{Tf} & TB & & \\ \downarrow a & \mu_A \searrow & \downarrow a & \Downarrow \tau & \downarrow b \\ TA & \xrightarrow{a} & A & \xrightarrow{f} & B \end{array} \\ \\ \begin{array}{ccccc} A & \xrightarrow{f} & B & \xrightarrow{\eta_B} & TB \\ \eta_A \searrow & = & \searrow & & \\ TA & \xrightarrow{Tf} & TB & & \\ \downarrow 1 & \eta_A \searrow & \downarrow a & \Downarrow \tau & \downarrow b \\ A & \xrightarrow{f} & A & \xrightarrow{f} & B \end{array} & = & \begin{array}{ccccc} A & \xrightarrow{f} & B & \xrightarrow{\eta_B} & TB \\ \downarrow 1 & \eta_A \searrow & \downarrow 1 & & \\ A & \xrightarrow{f} & A & \xrightarrow{f} & B \end{array} \end{array}$$

2.11. EXAMPLE. Let T be the 2-monad on \mathbf{Cat} whose strict algebras are weak monoidal categories. So given a category A , TA is the free weak monoidal category on A , with objects (parenthesised) words in objects of A . The multiplication μ acts by concatenation of words, and the unit η realises an object of A as a 1-ary word.

Then the weak maps are weak monoidal functors but expressed slightly differently from the usual way, with *a priori* a coherence isomorphism for every length of parenthesised word, not just binary and nullary words. This is because in the definition of weak map of algebras, the 2-cell isomorphism τ produces, for all objects of TA , a morphism in B . In this case, the objects of TA include parenthesised words of all finite lengths.

That is, not only do we have the usual specified coherence isomorphisms

$$Fx \otimes Fy \xrightarrow{\sim} F(x \otimes y)$$

and

$$I \xrightarrow{\sim} FI$$

but also coherence isomorphisms such as

$$Fx \otimes (Fy \otimes Fz) \xrightarrow{\sim} F(x \otimes (y \otimes z)).$$

However, the axioms for a weak map of algebras ensure that the coherence constraints for other arities must be built from the binary and nullary ones in the usual way, so that these (unbiased) weak maps coincide with the usual (biased) definition of weak monoidal functor.

We now consider 2-monads S, T with a distributive law, and characterise weak maps of TS -algebras in a manner similar to the strict maps. However, as the maps are now weak a new axiom is needed, governing the interaction between the constraint cells.

2.12. THEOREM. *Let S and T be 2-monads on a 2-category \mathcal{C} , and let $\lambda ST \implies TS$ be a 2-categorical distributive law. Then a weak map of TS -algebras*

$$\left(\begin{array}{c} TA \quad SA \\ \downarrow a_t \quad \downarrow a_s \\ A \quad A \end{array} \right) \longrightarrow \left(\begin{array}{c} TB \quad SB \\ \downarrow b_t \quad \downarrow b_s \\ B \quad B \end{array} \right)$$

is given by a 1-cell $A \xrightarrow{f} B$ and 2-cells as below giving individual weak maps:

$$\begin{array}{ccc} TA & \xrightarrow{Tf} & TB \\ a_t \downarrow & \tau \swarrow \sim & \downarrow b_t \\ A & \xrightarrow{f} & B \end{array} \qquad \begin{array}{ccc} SA & \xrightarrow{Sf} & SB \\ a_s \downarrow & \sigma \swarrow \sim & \downarrow b_s \\ A & \xrightarrow{f} & B \end{array}$$

such that the following “ σ/τ interaction axiom” holds:

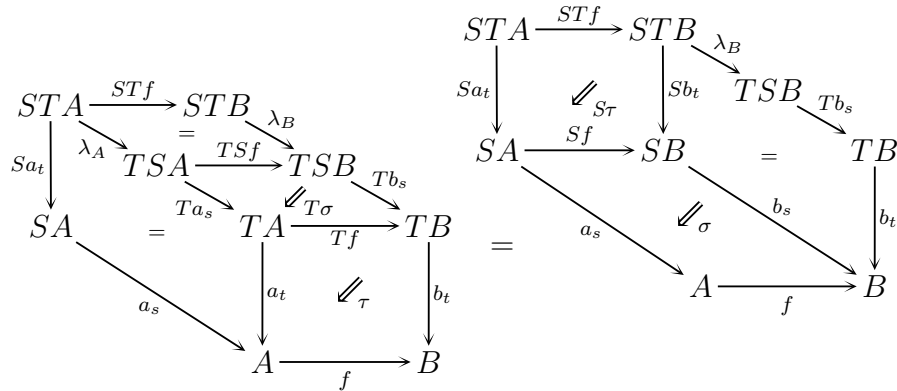

Note that as everything is strict here except the weak maps of algebras, there is a certain amount of overkill in using fully 2-dimensional pasting diagrams. In particular, the vast majority of faces in the diagrams are merely (strict) naturality squares. Under such circumstances, string diagram notation is particularly efficacious. All the proofs of commutativity in this section are entirely routine, and only complicated by the difficulty of notating 2-cells. Thus, we will defer many of the proofs to the appendix where we will use string diagrams.

PROOF. Consider a weak map

$$\begin{array}{ccc}
 TSA & \xrightarrow{TSf} & TSB \\
 a_{ts} \downarrow & \zeta \swarrow \sim & \downarrow b_{ts} \\
 A & \xrightarrow{f} & B
 \end{array}$$

First note that $\eta^T S : S \Rightarrow TS$ and $T\eta^S : T \Rightarrow TS$ give monad functors $TS \Rightarrow S$ and $TS \Rightarrow T$. Thus we know that σ and τ given as follows are weak maps of the constituent S -algebras and T -algebras respectively:

$$\begin{array}{ccc}
 SA & \xrightarrow{Sf} & SB \\
 \eta_{SA}^T \downarrow & \parallel & \downarrow \eta_{SB}^T \\
 TSA & \xrightarrow{TSf} & TSB \\
 a_{ts} \downarrow & \zeta \swarrow & \downarrow b_{ts} \\
 A & \xrightarrow{f} & B
 \end{array}
 \qquad
 \begin{array}{ccc}
 TA & \xrightarrow{Tf} & TB \\
 T\eta_A^S \downarrow & \parallel & \downarrow T\eta_B^S \\
 TSA & \xrightarrow{TSf} & TSB \\
 a_{ts} \downarrow & \zeta \swarrow & \downarrow b_{ts} \\
 A & \xrightarrow{f} & B
 \end{array}$$

We need to check the σ/τ interaction axiom; see Appendix.

Conversely, given individual weak maps σ and τ , we construct the following putative weak map of TS -algebras:

$$\begin{array}{ccc}
 TSA & \xrightarrow{TSf} & TSB \\
 \downarrow Ta_s & \Downarrow_{T\sigma} & \downarrow Tb_s \\
 TA & \xrightarrow{Tf} & TB \\
 \downarrow a_t & \Downarrow_{\tau} & \downarrow b_t \\
 A & \xrightarrow{f} & B
 \end{array}$$

We need to check the two axioms for an algebra; see Appendix. ■

2.13. TRANSFORMATIONS OF ALGEBRAS VIA DISTRIBUTIVE LAWS.

2.14. DEFINITION. Let T be a 2-monad on a 2-category \mathcal{C} . Given weak maps of T -algebras

$$\begin{array}{ccc}
 TA & \xrightarrow{Tf} & TB \\
 \downarrow a & \Downarrow_{\tau_f} & \downarrow b \\
 A & \xrightarrow{f} & B
 \end{array}
 \qquad
 \begin{array}{ccc}
 TA & \xrightarrow{Tg} & TB \\
 \downarrow a & \Downarrow_{\tau_g} & \downarrow b \\
 A & \xrightarrow{g} & B
 \end{array}$$

a transformation $f \Rightarrow g$ consists of a 2-cell

$$\begin{array}{ccc}
 & f & \\
 A & \Downarrow_{\alpha} & B \\
 & g &
 \end{array}$$

such that the following cylinder diagram commutes.

$$\begin{array}{ccc}
 \begin{array}{ccc}
 TA & \xrightarrow{Tf} & TB \\
 \downarrow a & \Downarrow_{T\alpha} & \downarrow b \\
 A & \xrightarrow{Tg} & B \\
 \downarrow a & \Downarrow_{\tau_g} & \downarrow b \\
 A & \xrightarrow{g} & B
 \end{array}
 & = &
 \begin{array}{ccc}
 TA & \xrightarrow{Tf} & TB \\
 \downarrow a & \Downarrow_{\tau_f} & \downarrow b \\
 A & \xrightarrow{f} & B \\
 \downarrow a & \Downarrow_{\alpha} & \downarrow b \\
 A & \xrightarrow{g} & B
 \end{array}
 \end{array}$$

We will refer to this as a T -algebra transformation for short, or just T -transformation. T -algebras, weak T -maps and T -transformations form a 2-category which we will call $T\text{-Alg}_w$.

2.15. EXAMPLE. Let T be the 2-monad on Cat for weak monoidal categories. Then a transformation between weak maps of T -algebras is a monoidal transformation. As for the weak maps, this is expressed slightly differently from the usual biased way, in that there is now a monoidality axiom for all parenthesised words and not just nullary/binary ones. However, again the concepts are the same because in the biased presentation the axioms for other arities can be derived from the nullary/binary ones. This allows us to consider $T\text{-Alg}_w$ as the 2-category of monoidal categories, weakly monoidal functors, and monoidal transformations.

2.16. **THEOREM.** *Let S and T be 2-monads on a 2-category \mathcal{C} , and let $\lambda ST \Longrightarrow TS$ be a 2-categorical distributive law. Then a transformation α of TS -algebras is precisely a 2-cell α that is both a transformation of S -algebras and a transformation of T -algebras (with no further axiom).*

PROOF. Consider a transformation of TS -algebras. As above, the monad functors $TS \Longrightarrow S$ and $TS \Longrightarrow T$ give us a transformation of S -algebras and T -algebras respectively. Conversely, suppose we have a 2-cell α that satisfies both the cylinder for T and the cylinder for S ; it is straightforward to check that it then satisfies the cylinder for TS . ■

3. Weak maps and transformations of doubly-degenerate \mathbf{Bicat}_s -categories

In this section we unravel the definitions of weak map and transformation in our case of interest, and go on to characterise these with reference only to the vertical monoidal structures. This is the technical content of the comparison with braided monoidal categories.

3.1. **WEAK MAPS BY DEFINITION.** In this section we unravel the definition of weak map in the case of doubly-degenerate \mathbf{Bicat}_s -categories.

Recall (Section 1.28) that we construct \mathbf{Bicat}_s -categories from 2-monads V for vertical composition and H for horizontal composition, equipped with a distributive law of V over H . These are monads on the 2-category $\mathbf{Cat}\text{-}\mathbf{Gph}\text{-}\mathbf{Gph}$. By definition, the doubly-degenerate HV -algebras are those whose underlying data is doubly-degenerate, that is, whose underlying $\mathbf{Cat}\text{-}\mathbf{Gph}$ -graph has only one 0-cell and only one 1-cell. In this case the underlying data is just a category A . Then

- a V -algebra structure is a (weak) monoidal structure on A , and
- an H -algebra structure is a (strict) monoidal structure on A .

As in [CC22] we will write the V -algebra (weak monoidal) structure vertically as $\frac{a}{b}$ and the H -algebra (strict monoidal) structure horizontally as $a|b$. As we have strict interchange between these monoidal structures we can combine these in grids without ambiguity, for example:

$$\frac{a|b}{c|d}$$

Furthermore, we will often ignore issues of associativity in the vertical direction because, as long as we are not simultaneously interacting with associativity in the horizontal direction, coherence means that the diagram of vertical associators will commute. (We know from [Koc06] that care must be taken about the interaction between horizontal and vertical

associativity.) Thus we will work with larger grids such as

$$\begin{array}{c|c} a & b \\ \hline c & d \\ \hline e & f \end{array}$$

but will only increase the height when the width remains at two. By interchange we know that the horizontal and vertical monoidal unit are the same, and we write it as 1; we will sometimes write it as an empty space in a grid formation. We will write the left and right unit constraints for the horizontal tensor product as follows (with λ and ρ for “left” and “right”):

$$\begin{array}{c|c} 1 & a \xrightarrow{\lambda} a \\ a & 1 \xrightarrow{\rho} a \end{array}$$

and those for the vertical tensor product as follows (with τ and β for “top” and “bottom”):

$$\begin{array}{c} \frac{1}{a} \xrightarrow{\tau} a \\ \frac{a}{1} \xrightarrow{\beta} a \end{array}$$

3.2. DEFINITION. *We define a weak map of doubly-degenerate \mathbf{Bicat}_s -categories to be a weak map of their HV-algebra structures.*

We can now use the results of the previous section to characterise these weak maps via the horizontal and vertical monoidal structures.

3.3. PROPOSITION. *A weak map $X \xrightarrow{F} Y$ of doubly-degenerate \mathbf{Bicat}_s -categories is a functor on the underlying categories equipped with:*

- *A vertical monoidality constraint: for all $a, b \in X$ an isomorphism*

$$\frac{Fa}{Fb} \xrightarrow[\sim]{v_{ab}} F\left(\frac{a}{b}\right)$$

natural in a and b ; we will usually omit the subscripts.

- *A horizontal monoidality constraint: for all $a, b \in X$ an isomorphism*

$$Fa | Fb \xrightarrow[\sim]{h_{ab}} F(a | b)$$

natural in a and b ; again we will usually omit the subscripts.

- *A unit constraint: an isomorphism $1 \xrightarrow[\sim]{\eta} F1$.*

These must satisfy the usual axioms for monoidal functors, plus the interaction axiom:

$$\begin{array}{ccc}
 \frac{Fa \mid Fb}{Fc \mid Fd} & \xrightarrow{\frac{h}{\hbar}} & \frac{F(a \mid b)}{F(c \mid d)} \\
 \downarrow v \mid v & & \downarrow v \\
 F\left(\frac{a}{c} \mid \frac{b}{d}\right) & \xrightarrow{h} & F\left(\frac{a \mid b}{c \mid d}\right)
 \end{array}$$

Note that is essentially a “biased” presentation of the interaction axiom in the previous section.

PROOF. By Theorem 2.12 we know that a weak HV -map is equivalently a map with the structure of both a weak H -map and a weak V -map satisfying the interaction axiom. Thus as in Example 2.11 the structure of the weak V -map gives us unbiased vertical monoidality constraints, and the structure of the weak H map gives us unbiased horizontal monoidality constraint, and a general interaction axiom (for all arities in both directions). The interaction axiom gives us interaction for all vertical and horizontal arities. In particular in the nullary case it tells us that the horizontal and vertical unit constraints $1 \rightarrow F1$ must coincide; in the case of a binary arity in both directions, the axioms tells us that the 2-by-2 interaction axiom above must hold. Conversely, starting from the interaction axiom for arity 0 and 2-by-2, we can prove the general interaction axiom by double induction. ■

3.4. WEAK MAPS IN TERMS OF VERTICAL STRUCTURE. We are now going to use a weak Eckmann–Hilton argument to re-characterise these weak maps further, eliminating the reference to H . First recall from [CC22] that a doubly-degenerate \mathbf{Bicat}_s -category has the structure of a braided monoidal category with respect to its vertical tensor product,

with braiding given by a weak Eckmann–Hilton argument as follows:

$$\begin{array}{c}
 \frac{a}{b} \\
 \parallel \begin{array}{l} \text{strict horizontal units} \\ \text{strict interchange} \end{array} \\
 \frac{a}{b} \\
 \downarrow \begin{array}{l} \wr \\ \text{weak vertical units} \end{array} \\
 b \mid a \\
 \downarrow \begin{array}{l} \wr \\ \text{weak vertical units} \end{array} \\
 \frac{b}{a} \\
 \parallel \begin{array}{l} \text{strict horizontal units} \\ \text{strict interchange} \end{array} \\
 \frac{b}{a}
 \end{array}$$

Note that this involves a choice of orientation; we will keep the above “clockwise” orientation throughout. As we will invoke this repeatedly we will express it in terms of the following maps:

$$\alpha \ a \mid b \longrightarrow \frac{a}{b}$$

and

$$\bar{\alpha} \ a \mid b \longrightarrow \frac{b}{a}$$

We can think of α as being clockwise and $\bar{\alpha}$ as anti-clockwise. Then the braiding in the orientation we have chosen above is given as follows:

$$\gamma := \frac{a}{b} \xrightarrow{\bar{\alpha}^{-1}} b \mid a \xrightarrow{\alpha} \frac{b}{a}$$

We will refer to this as the *standard braiding*.

Note that α and $\bar{\alpha}$ are built from unit constraints so are natural in a and b . Another key result we need encapsulates the usual way in which we extract a braiding from interchange.

3.5. PROPOSITION. *The following diagram commutes.*

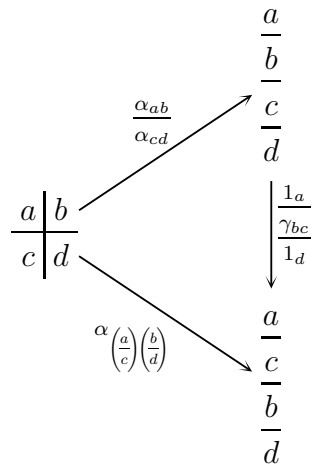

PROOF. The diagram in question is the outside of the diagram below.

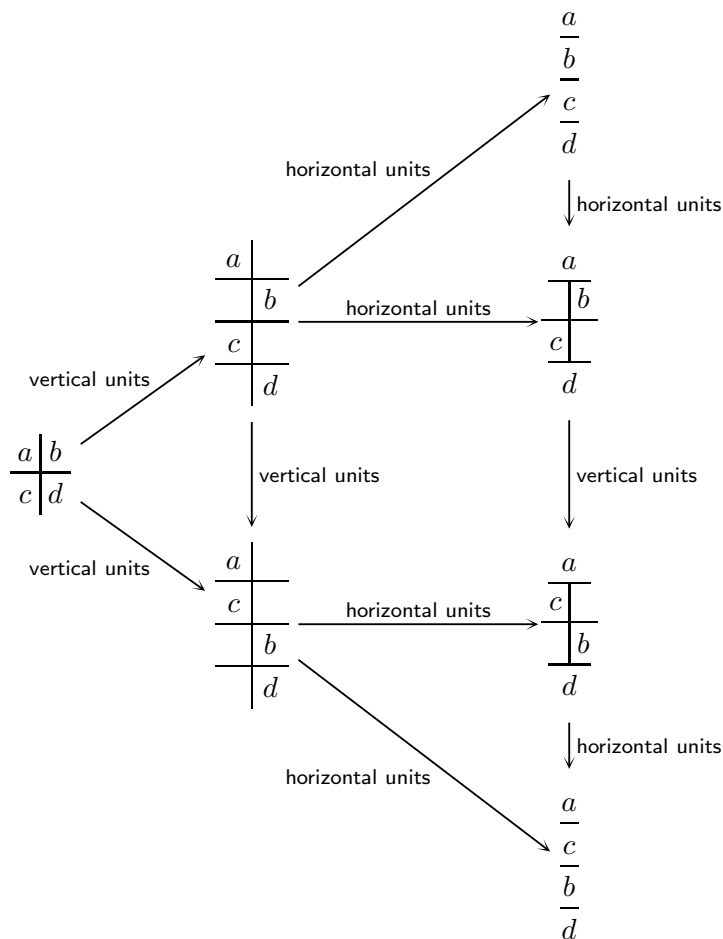

We see that each triangle involves only one type of unit constraint and so commutes by coherence. The square commutes by functoriality of vertical tensor product.

■

We are now ready to characterise the weak maps of HV -algebras in terms of just the vertical structure, that is, in terms of V -structure and the braiding. In some sense the following proposition is just a corollary of [CG11, Theorem 2.14], where it was proved in much greater generality (for fully weak tricategories). However, as that proof involved long coherence calculations we deem it worthwhile to include a direct proof here. First we show that a weak map of HV -algebras is a braided monoidal functor with respect to the V -structure; afterwards we will show that given a braided monoidal functor, a weak HV -map giving rise to it can be reconstructed.

3.6. PROPOSITION. *Let $(F, v, h) X \longrightarrow Y$ be a weak map of doubly-degenerate \mathbf{Bicat}_s -categories. Then F is a braided monoidal functor with respect to the vertical tensor product and the standard braiding. That is, the following diagram commutes:*

$$\begin{array}{ccc} \frac{Fa}{Fb} & \xrightarrow{v} & F\left(\frac{a}{b}\right) \\ \gamma \downarrow & & \downarrow F\gamma \\ \frac{Fb}{Fa} & \xrightarrow{v} & F\left(\frac{b}{a}\right) \end{array}$$

PROOF. The diagram can be seen to commute as shown below. Here “unit” refers to the unit axiom for a monoidal functor.

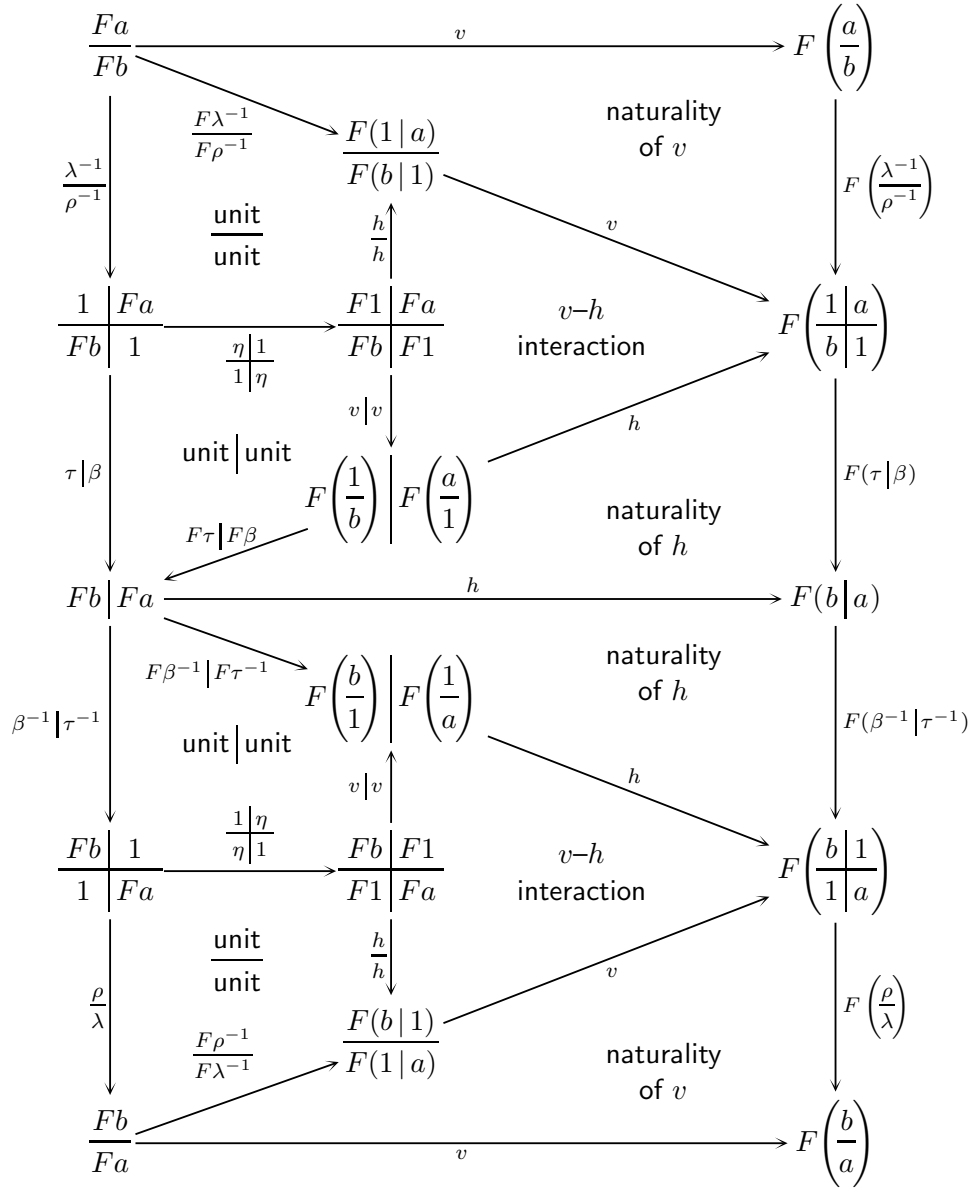

■

Note that the diagram in the above proof splits into two halves (top and bottom) and the halves are themselves key for what follows, showing that, given a weak HV -map, the h constraint can always be derived from v .

3.7. PROPOSITION. Let (F, v, h) be a weak map of doubly-degenerate Bicat_s -categories $X \rightarrow Y$. It follows from the above proof that the following diagram commutes, showing that h can be derived from v (as α and thus $F\alpha$ are invertible):

$$\begin{array}{ccc}
 Fa|Fb & \xrightarrow{h} & F(a|b) \\
 \alpha \downarrow & & \downarrow F\alpha \\
 \frac{Fa}{Fb} & \xrightarrow{v} & F\left(\frac{a}{b}\right)
 \end{array}$$

Note that this means that if we know we have a weak HV -map, then h can be reconstructed from v , but if we started with only v we might not be able to make it into a weak HV -map. It remains to show that any v satisfying the braid axiom will yield a weak map by reconstructing h according to this diagram.

The idea is that if we start with a constraint v there are two options for extending the weak map structure, depending on how we're thinking about the overall structure. Either we're thinking about braided monoidal categories in which case we want v to satisfy the braid axiom. Or we're thinking about HV -algebras in which case we want to reconstruct an h and check the interaction axiom. The point is that these turn out to be equivalent.

3.8. PROPOSITION. *Let X and Y be doubly-degenerate \mathbf{Bicat}_s -categories and (F, v) a monoidal functor $X \rightarrow Y$ with respect to the vertical tensor products, satisfying the braid axiom. Then defining h according to Proposition 3.7 makes F into a weak map of doubly-degenerate \mathbf{Bicat}_s -categories.*

PROOF. We need to show that with h defined in this way the interaction axiom holds. This is seen by the following diagram; the outside is the interaction axiom, and we see that it follows from the braid axiom.

edges of the diagram below. Thus the monoidal transformation diagram we need to check becomes the outside of the diagram below, which is seen to commute as shown:

$$\begin{array}{ccccccc}
 Fa \mid Fb & \xrightarrow{\alpha} & \frac{Fa}{Fb} & \xrightarrow{v} & F\left(\frac{a}{b}\right) & \xrightarrow{F\alpha^{-1}} & F(a \mid b) \\
 \theta_a \mid \theta_b \downarrow & \text{naturality} & \downarrow \theta_a & \text{vertical} & \downarrow \theta_{\frac{a}{b}} & \text{naturality} & \downarrow \theta_a \mid b \\
 & \text{of } \alpha & \theta_b & \text{monoidal} & & \text{of } \theta & \\
 & & & \text{axiom} & & & \\
 Ga \mid Gb & \xrightarrow{\alpha} & \frac{Ga}{Gb} & \xrightarrow{v} & G\left(\frac{a}{b}\right) & \xrightarrow{G\alpha^{-1}} & G(a \mid b)
 \end{array}$$

■

Note that doubly-degenerate \mathbf{Bicat}_s -categories, weak maps, and transformations between them form a 2-category which we will write as $\mathbf{ddBicat}_s\text{-Cat}$; it is a full sub-2-category of $HV\text{-Alg}_w$.

4. Biadjoint biequivalence

We are now ready to state and prove our main theorem. We exhibit a comparison 2-functor between $\mathbf{ddBicat}_s\text{-Cat}$ and $\mathbf{BrMonCat}$ and prove that it is part of a biadjoint biequivalence. Here we write $\mathbf{BrMonCat}$ for the 2-category of braided (weakly) monoidal categories, weak monoidal functors between them, and monoidal transformations.

In fact, all the technical components of the equivalence have been proved in [CC22] and the previous section, so this is just a case of bringing all those results together.

4.1. THEOREM. [Main Theorem] *There is a 2-functor*

$$U \mathbf{ddBicat}_s\text{-Cat} \longrightarrow \mathbf{BrMonCat}$$

extending the construction on 0-cells given in [CC22], and it is part of a biadjoint biequivalence of 2-categories.

PROOF. First we construct the 2-functor U .

- On 0-cells: given a doubly-degenerate \mathbf{Bicat}_s -category X , UX is the braided monoidal category given by the vertical tensor product and the standard braiding γ .
- On 1-cells: given a weak map of doubly-degenerate \mathbf{Bicat}_s -categories

$$(F, v, h) X \longrightarrow Y$$

UF is the associated braided monoidal functor (F, v) , which we know is braided by Proposition 3.6.

- On 2-cells: given a transformation between weak maps of doubly-degenerate \mathbf{Bicat}_s -categories

$$\begin{array}{ccc}
 & F & \\
 X & \begin{array}{c} \curvearrowright \\ \Downarrow \theta \\ \curvearrowleft \end{array} & Y \\
 & G &
 \end{array}$$

$U\theta$ is the underlying transformation with respect to just the vertical monoidal structure.

This is a strict 2-functor. The main theorem of [CC22] proved that U is biessentially surjective on 0-cells. By Proposition 3.8 we know U is locally essentially surjective on 1-cells (in fact locally surjective). By Proposition 3.11 we know U is locally full and faithful on 2-cells. Then by [Gur12, Lemma 3.1 and Theorem 3.2] it follows that U is part of a biadjoint biequivalence of 2-categories. ■

Note that constructing a pseudo-inverse for U is non-trivial. A candidate construction on 0-cells was made in [CC22] to prove the biessential surjectivity, but extending it to a 2-functor requires more work and we defer it to a sequel.

In future work we will perform an analogous analysis for doubly-degenerate tricategories according to the theory of Trimble [Tri99]. This theory uses iterated enrichment with more general operad actions, with the result that, although the ideas are analogous, the technicalities are a little more intricate.

A. String diagram calculations

In this section we will give the deferred 2-categorical proofs that are more efficaciously performed using string diagrams. The advantage of string diagrams in this case is that almost all our 2-categorical concepts are strict, and so we can “ignore” naturality squares. The conventions we use are as follows. We read the diagrams from top to bottom. We are working with 2-categories, 2-functors, and transformations (all strict), so in particular the relative heights do not matter (because of naturality). To simplify the diagrams we will omit labels wherever there is no ambiguity.

A.1. MONADS AND DISTRIBUTIVE LAWS. We begin by laying out our basic notation for the classical results of 2-monads and distributive laws. For a 2-monad T on a 2-category \mathcal{C} , we write its multiplication, unit, and axioms as follows.

$$\begin{array}{c} T T \\ \text{Y} \\ T \end{array} = \begin{array}{c} 1 \\ \text{!} \\ T \end{array} \qquad \begin{array}{c} \text{Y} \\ \text{Y} \end{array} = \begin{array}{c} \text{Y} \\ \text{Y} \end{array} \qquad \begin{array}{c} \text{!} \\ \text{Y} \end{array} = \begin{array}{c} | \\ \text{Y} \end{array} = \begin{array}{c} \text{Y} \\ \text{!} \end{array}$$

We write a distributive law $ST \Rightarrow TS$ as

$$\begin{array}{c} S T \\ \times \\ T S \end{array}$$

and the axioms for a distributive law as follows:

$$\begin{array}{c} S S T \\ \text{Y} \\ T \end{array} = \begin{array}{c} \text{Y} \\ \text{Y} \end{array} \qquad \begin{array}{c} S T T \\ \text{Y} \\ T \end{array} = \begin{array}{c} \text{Y} \\ \text{Y} \end{array} \qquad \begin{array}{c} T \\ \text{Y} \\ T S \end{array} = \begin{array}{c} T \\ | \\ T S \end{array} \qquad \begin{array}{c} S \\ \text{Y} \\ T S \end{array} = \begin{array}{c} \text{!} \\ | \\ T S \end{array}$$

Given such a distributive law, TS becomes a monad with the following multiplication and unit:

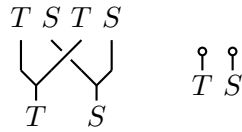

We write an algebra for a monad T as follows, together with its axioms. (Note that this can be made consistent with the string diagram notation by regarding the object A as a functor $1 \rightarrow \mathcal{C}$.)

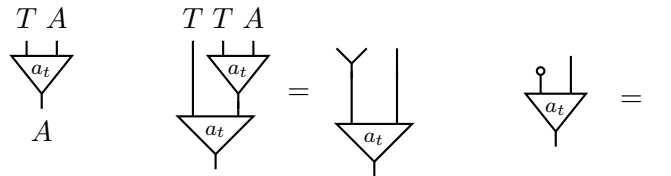

We now turn to algebras for a composite monad TS arising from a distributive law. Corollory 2.2 says that a TS -algebra is equivalently a T algebra and an S -algebra satisfying the following interaction axiom.

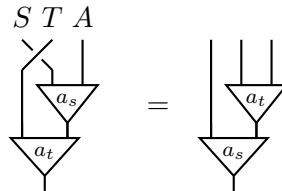

Given a TS -algebra a_{ts} we produce an S -algebra and a T -algebra as follows; it is then quite straightforward to check they satisfy the interaction axiom using the diagrams.

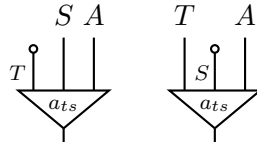

Conversely, given an S -algebra a_s and a T -algebra a_t we construct a putative TS -algebra as follows, and can then use the string diagrams to check that the algebra axioms follow from the interaction axiom. (That is, the multiplication axiom follows from the interaction axiom; the unit axiom follows from the individual unit axioms.)

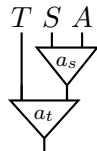

A.2. WEAK MAPS OF ALGEBRAS. We now address weak maps of algebras. Note that in all that follows, we will label 2-cells between string diagrams just with the name of the non-trivial part of the 2-cell.

A weak map of algebras

$$\left(\begin{array}{c} TA \\ \downarrow a_t \\ A \end{array} \right) \longrightarrow \left(\begin{array}{c} TB \\ \downarrow b_t \\ B \end{array} \right)$$

consists of a 1-cell $A \xrightarrow{f} B$ and a 2-cell isomorphism as shown below

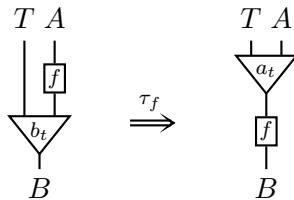

satisfying the following axioms:

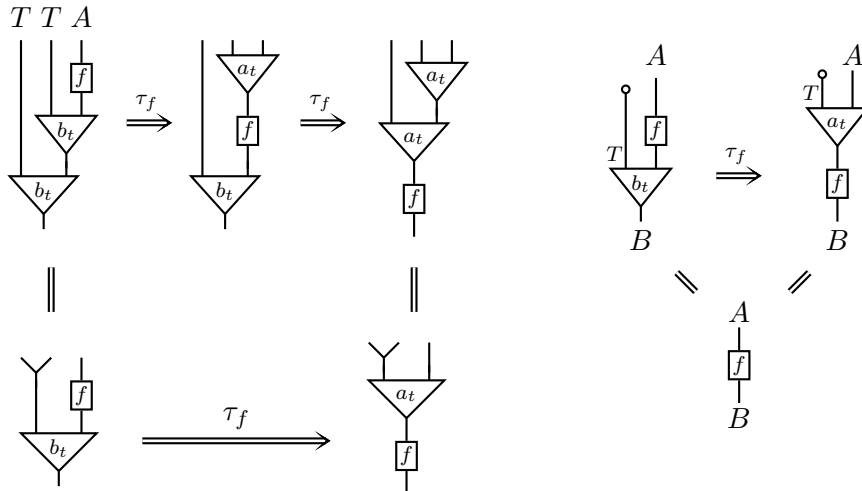

Note that, as above, we can make this consistent with the string diagrams: if we are regarding a 0-cell A as a 2-functor $1 \rightarrow A$, then a 1-cell $f : A \rightarrow B$ is a strict transformation, and a 2-cell $f \Rightarrow g$ is a modification.

We now turn to weak maps for the composite monad TS arising from a distributive law. We know that a TS -algebra structure on A can be expressed as a pair (a_s, a_t) where a_s is an S -algebra structure on A and a_t is a T -algebra structure on A and they satisfy the interaction axiom. Theorem 2.12 says that a weak map of TS -algebras

$$\left(\begin{array}{cc} TA & SA \\ \downarrow a_t & \downarrow a_s \\ A & A \end{array} \right) \longrightarrow \left(\begin{array}{cc} TB & SB \\ \downarrow b_t & \downarrow b_s \\ B & B \end{array} \right)$$

is given by

- a 1-cell $A \xrightarrow{f} B$

- 2-cells σ_f and τ_f as shown below giving the structure of a weak map of underlying S -algebras and a weak map of underlying T -algebras,

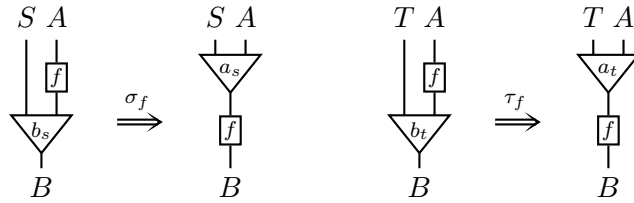

- satisfying the interaction axiom shown below.

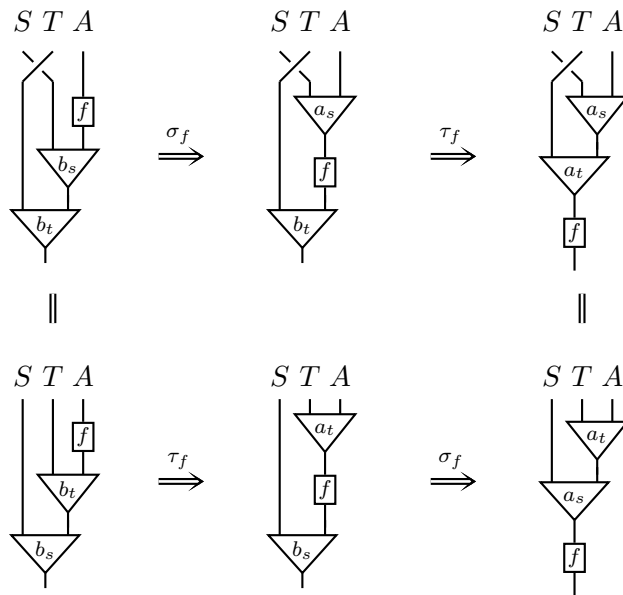

Proof of Theorem 2.12. Now, *a priori* a weak map of TS -algebras is a 1-cell $A \xrightarrow{f} B$ and a 2-cell

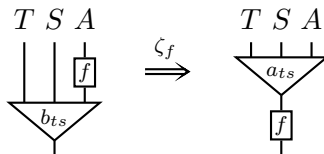

such that the following diagrams commute:

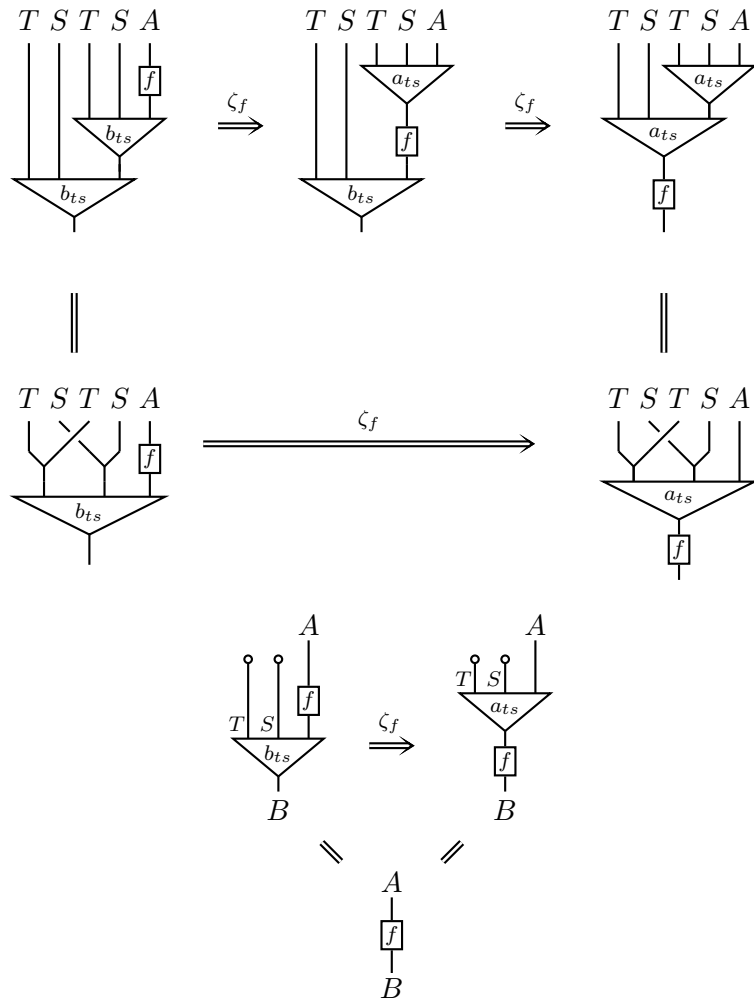

First we will show that this gives a pair (σ_f, τ_f) satisfying interaction. We begin by expressing the TS -algebras a_{ts} and b_{ts} as λ -distributive pairs:

$$\left(\begin{array}{c} \begin{array}{c} S \ A \\ | \ | \\ \circ \ | \\ | \ | \\ \triangleleft \\ a_{ts} \\ | \\ A \end{array} \quad \begin{array}{c} T \ A \\ | \ | \\ \circ \ | \\ | \ | \\ \triangleleft \\ a_{ts} \\ | \\ A \end{array} \end{array} \right) \quad \left(\begin{array}{c} \begin{array}{c} S \ B \\ | \ | \\ \circ \ | \\ | \ | \\ \triangleleft \\ b_{ts} \\ | \\ B \end{array} \quad \begin{array}{c} T \ B \\ | \ | \\ \circ \ | \\ | \ | \\ \triangleleft \\ b_{ts} \\ | \\ B \end{array} \end{array} \right)$$

Next we construct σ for the S components and τ for the T components as shown below.

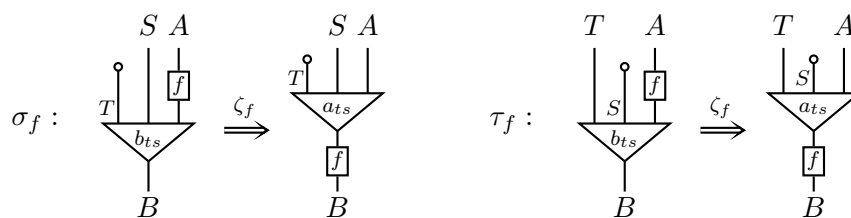

We check the interaction diagram:

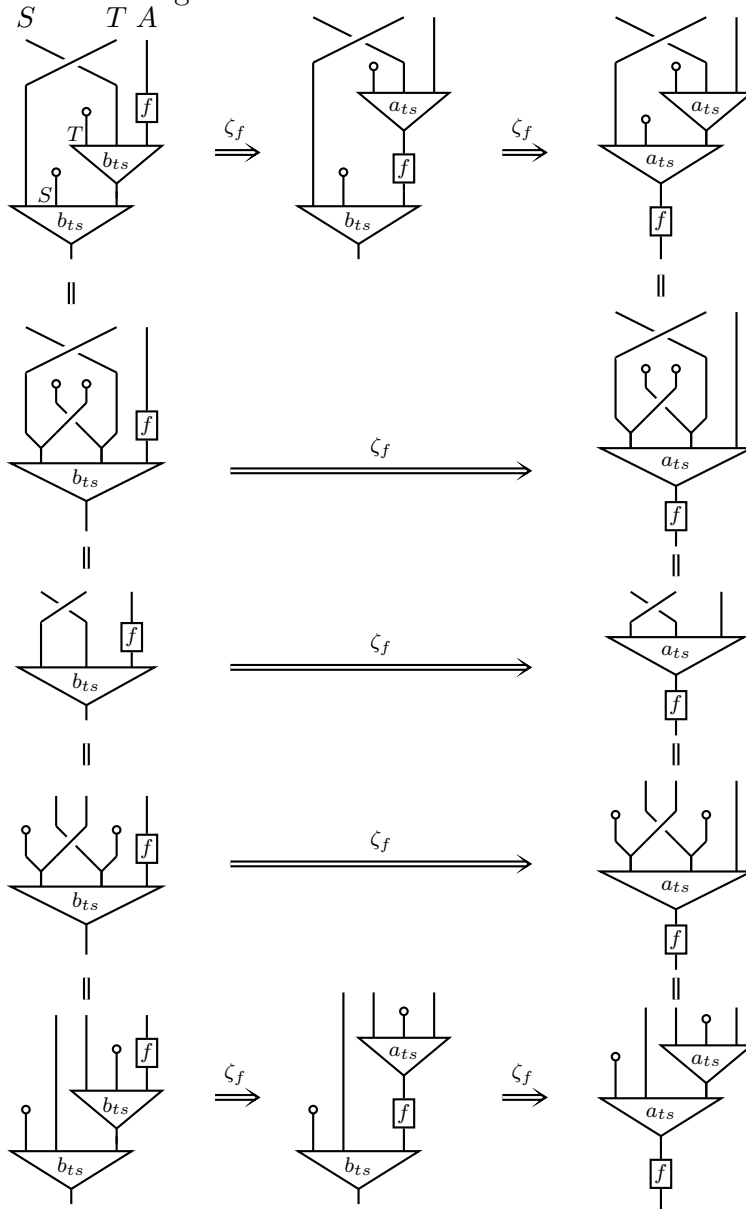

Conversely, suppose we have a pair (σ_f, τ_f) as below satisfying the interaction diagram.



We show that these result in a weak map of TS -algebras. First we form the 2-cell ζ_f as shown below.

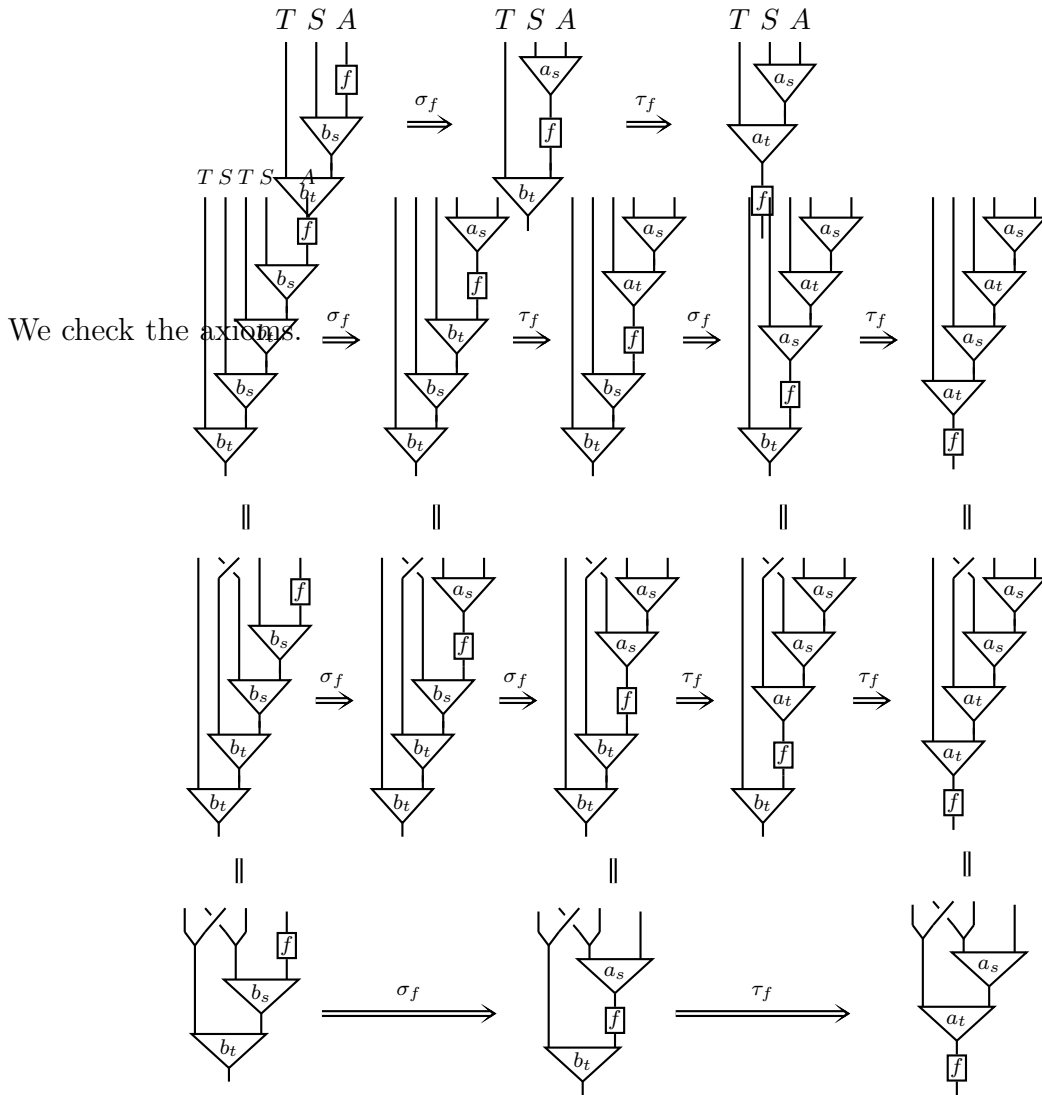

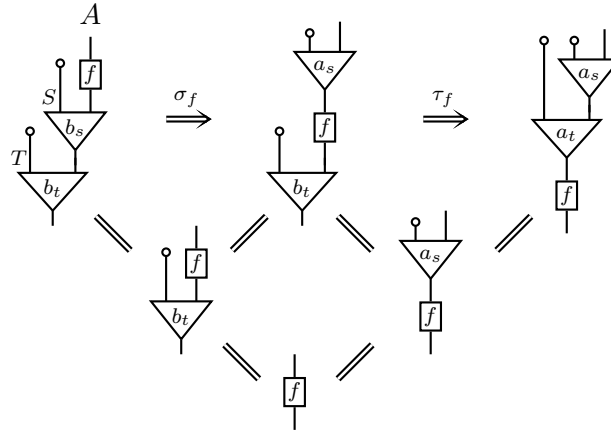

Finally we check that these assignments are inverse to each other. We start with ζ_f , construct individual weak maps σ_f and τ_f , compile them back into a weak TS -map and check that this is equal to ζ_f . This is seen from the commutativity of the following diagram, where the top region is the multiplication axiom for a weak map of TS -algebras.

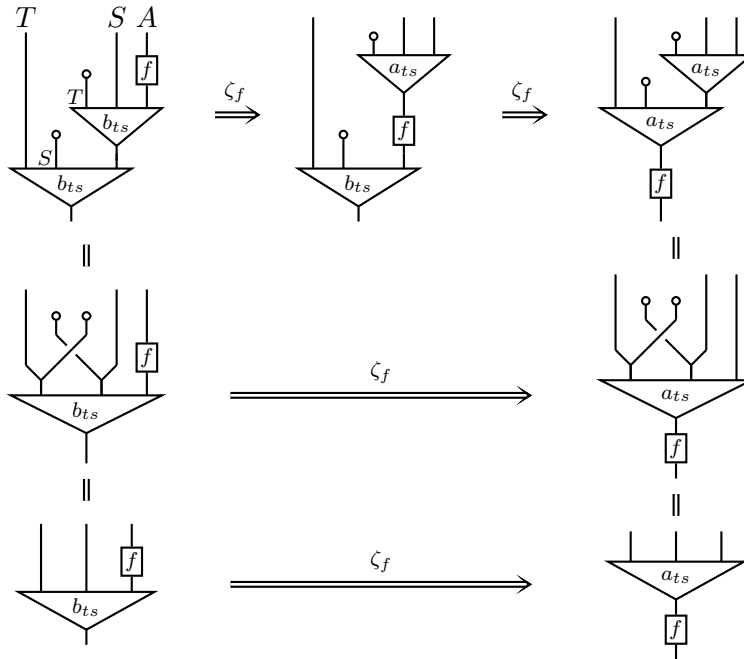

Conversely, start with σ_f and τ_f , make ζ_f , and then extract individual weak S -map and T -map constraints out, and check that these are equal to the σ_f and τ_f we started with. This is seen from the commutativity of the following diagrams; in each case the triangle commutes by the triangle axiom for a weak map.

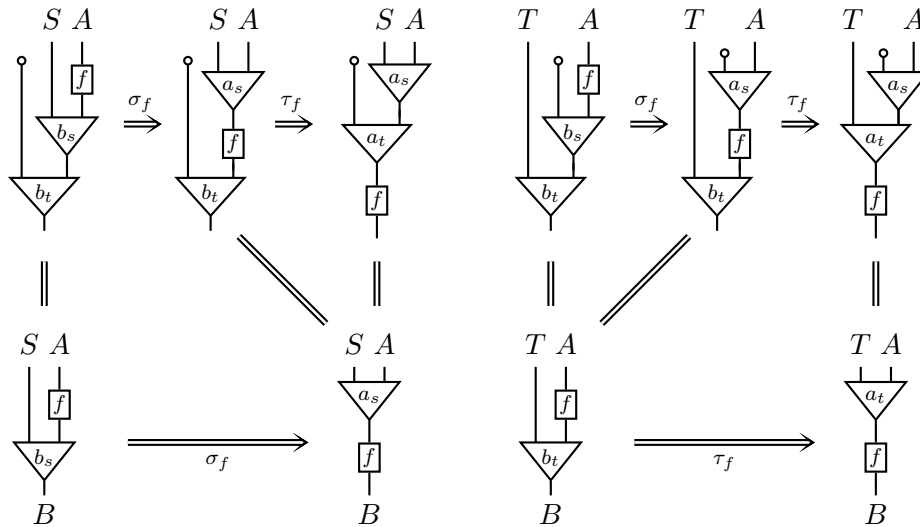

References

- [AM10] M. Aguiar and S. Mahajan. Monoidal functors, species and hopf algebras. *CRM Monoidal Series*, 29, 2010.
- [BD95] John Baez and James Dolan. Higher-dimensional algebra and topological quantum field theory. *Jour. Math. Phys.*, 36:6073–6105, 1995.
- [Bec69] J. Beck. Distributive laws. *Lecture Notes in Mathematics*, 80:119–140, 1969.
- [CC22] Eugenia Cheng and Alexander S. Corner. Weak vertical composition, 2022, 2212.11865.
- [CG07] Eugenia Cheng and Nick Gurski. The periodic table of n -categories for low dimensions I: degenerate categories and degenerate bicategories. In Batanin, Davydov, Johnson, Lack, and Neeman, editors, *Categories in Algebra, Geometry and Mathematical Physics, proceedings of Streetfest*, volume 431 of *Contemporary Math.*, pages 143–164. AMS, 2007. E-print 0708.1178.
- [CG11] Eugenia Cheng and Nick Gurski. The periodic table of n -categories for low dimensions II: degenerate tricategories. *Cahiers de Topologie et Géométrie Différentielle Catégoriques*, 52:82–125, 2011. E-print 0706.2307.
- [CG14] Eugenia Cheng and Nick Gurski. Iterated icons. *Theory and Applications of Categories*, 29:929–977, 2014, 1308.6495.
- [Che11a] Eugenia Cheng. Comparing operadic theories of n -category. *Homology, Homotopy and Applications*, 13(2):217–249, 2011. Also E-print 0809.2070.

- [Che11b] Eugenia Cheng. Iterated distributive laws. *Mathematical Proceedings of the Cambridge Philosophical Society*, 150(3):459–487, 2011. Also E-print 0710.1120.
- [CHP04] Eugenia Cheng, Martin Hyland, and John Power. Pseudo-distributive laws. *Electronic Notes in Theoretical Computer Science*, 83, 2004.
- [CL19] Eugenia Cheng and Tom Leinster. Weak infinity-categories via terminal coalgebras. *Theory and Applications of Categories*, (34):1073–1133, 2019. E-print 1212.5853.
- [GG09] Richard Garner and Nick Gurski. The low-dimensional structures formed by tricategories. *Mathematical Proceedings of the Cambridge Philosophical Society*, 146:551–589, 2009.
- [Gur12] Nick Gurski. Biequivalences in tricategories. *Theory and Applications of Categories*, 26(14):349–384, 2012. E-print 1102.0979.
- [JK07] André Joyal and Joachim Kock. Weak units and homotopy 3-types. In Batanin, Davydov, Johnson, Lack, and Neeman, editors, *Categories in Algebra, Geometry and Mathematical Physics, proceedings of Streetfest*, volume 431 of *Contemporary Math.*, pages 257–276. AMS, 2007.
- [Koc06] Joachim Kock. Note on commutativity in double semigroups and two-fold monoidal categories. *Journal of Homotopy and Related Structures*, 2, 2006, math/0608452. E-print math/0608452.
- [KS74] G. M. Kelly and Ross Street. Review of the elements of 2-categories. In *Category Seminar*, volume 420 of *Springer Lecture Notes in Mathematics*, pages 75–103, 1974.
- [Lac10] Stephen Lack. Icons. *Applied Categorical Structures*, 18(3):289–307, 2010. E-print 0711.4657.
- [Lei04] Tom Leinster. *Higher operads, higher categories*. Number 298 in London Mathematical Society Lecture Note Series. Cambridge University Press, 2004.
- [LP08] Steve Lack and Simona Paoli. 2-nerves for bicategories. *K-Theory*, 38(2):153–175, 2008. E-print math.CT/0607271.
- [Shu12] Michael Shulman. Not every pseudoalgebra is equivalent to a strict one. *Adv. Math.*, 229(3):2024–2041, 2012, arXiv:1005.1520. E-print 1005.1520.
- [Str72] Ross Street. The formal theory of monads. *Journal of Pure and Applied Algebra*, 2:149–168, 1972.

- [Tri99] Todd Trimble. What are ‘fundamental n -groupoids’?, 1999. Seminar at DP-MMS, Cambridge, 24 August 1999.

*School of the Art Institute of Chicago
112 S. Michigan Avenue, Chicago, IL 60605, USA*

*Department of Engineering and Mathematics, Sheffield Hallam University
Howard St, Sheffield S1 1WB, UK*

Email: info@eugeniacheng.com, alex.corner@shu.ac.uk

This article may be accessed at <http://www.tac.mta.ca/tac/>

THEORY AND APPLICATIONS OF CATEGORIES will disseminate articles that significantly advance the study of categorical algebra or methods, or that make significant new contributions to mathematical science using categorical methods. The scope of the journal includes: all areas of pure category theory, including higher dimensional categories; applications of category theory to algebra, geometry and topology and other areas of mathematics; applications of category theory to computer science, physics and other mathematical sciences; contributions to scientific knowledge that make use of categorical methods. Articles appearing in the journal have been carefully and critically refereed under the responsibility of members of the Editorial Board. Only papers judged to be both significant and excellent are accepted for publication.

SUBSCRIPTION INFORMATION Individual subscribers receive abstracts of articles by e-mail as they are published. To subscribe, send e-mail to tac@mta.ca including a full name and postal address. Full text of the journal is freely available at <http://www.tac.mta.ca/tac/>.

INFORMATION FOR AUTHORS L^AT_EX₂ ϵ is required. Articles may be submitted in PDF by email directly to a Transmitting Editor following the author instructions at <http://www.tac.mta.ca/tac/authinfo.html>.

MANAGING EDITOR. Geoff Cruttwell, Mount Allison University: gcruttwell@mta.ca

T_EXNICAL EDITOR. Michael Barr, McGill University: michael.barr@mcgill.ca

ASSISTANT T_EX EDITOR. Gavin Seal, Ecole Polytechnique Fédérale de Lausanne: gavin_seal@fastmail.fm

TRANSMITTING EDITORS.

Clemens Berger, Université de Nice-Sophia Antipolis: cberger@math.unice.fr

Julie Bergner, University of Virginia: jeb2md@virginia.edu

Richard Blute, Université d' Ottawa: rblute@uottawa.ca

John Bourke, Masaryk University: bourkej@math.muni.cz

Maria Manuel Clementino, Universidade de Coimbra: mmc@mat.uc.pt

Valeria de Paiva, Topos Institute: valeria.depaiva@gmail.com

Richard Garner, Macquarie University: richard.garner@mq.edu.au

Ezra Getzler, Northwestern University: getzler@northwestern.edu

Rune Haugseng, Norwegian University of Science and Technology: rune.haug seng@ntnu.no

Dirk Hofmann, Universidade de Aveiro: dirk@ua.pt

Joachim Kock, Universitat Autònoma de Barcelona: Joachim.Kock@uab.cat

Stephen Lack, Macquarie University: steve.lack@mq.edu.au

Tom Leinster, University of Edinburgh: Tom.Leinster@ed.ac.uk

Sandra Mantovani, Università degli Studi di Milano: sandra.mantovani@unimi.it

Matias Menni, Conicet and Universidad Nacional de La Plata, Argentina: matias.menni@gmail.com

Giuseppe Metere, Università degli Studi di Palermo: giuseppe.metere@unipa.it

Kate Ponto, University of Kentucky: kate.ponto@uky.edu

Robert Rosebrugh, Mount Allison University: rrosebrugh@mta.ca

Jiri Rosický, Masaryk University: rosicky@math.muni.cz

Giuseppe Rosolini, Università di Genova: rosolini@unige.it

Michael Shulman, University of San Diego: shulman@sandiego.edu

Alex Simpson, University of Ljubljana: Alex.Simpson@fmf.uni-lj.si

James Stasheff, University of North Carolina: jds@math.upenn.edu

Tim Van der Linden, Université catholique de Louvain: tim.vanderlinden@uclouvain.be

Christina Vasilakopoulou, National Technical University of Athens: cvasilak@math.ntua.gr