

Silicon Carbide Enabled Medium Voltage DC Transmission Systems for Rapid Electric Vehicle Charging in the UK

DEB, Arkadeep, GONZALEZ, Jose-Ortiz, WU, Ruizhu, ISSA, Walid <<http://orcid.org/0000-0001-9450-5197>>, JAHDI, Saeed and ALATISE, Olayiwola

Available from Sheffield Hallam University Research Archive (SHURA) at:

<http://shura.shu.ac.uk/31788/>

This document is the author deposited version. You are advised to consult the publisher's version if you wish to cite from it.

Published version

DEB, Arkadeep, GONZALEZ, Jose-Ortiz, WU, Ruizhu, ISSA, Walid, JAHDI, Saeed and ALATISE, Olayiwola (2023). Silicon Carbide Enabled Medium Voltage DC Transmission Systems for Rapid Electric Vehicle Charging in the UK. In: 27th International Conference on Electricity Distribution (CIRED 2023). IET Digital Library, 2074-2078.

Copyright and re-use policy

See <http://shura.shu.ac.uk/information.html>

SILICON CARBIDE ENABLED MEDIUM VOLTAGE DC TRANSMISSION SYSTEMS FOR RAPID ELECTRIC VEHICLE CHARGING IN THE UK

Arkadeep DEB
University of Warwick, UK
Arkadeep.deb@warwick.ac.uk

Jose-Ortiz GONZALEZ
University of Warwick, UK
j.a.ortiz-gonzalez@warwick.ac.uk

Ruizhu WU
Chongqing Powertrain co., LTD, China
ruizhu.wu@seres.cn

Walid ISSA
Sheffield Hallam University, UK
walid.issa@shu.ac.uk

Saeed JAHDI
University of Bristol, UK
Saeed.jahdi@bristol.ac.uk

Olayiwola ALATISE
University of Warwick, UK
O.Alatise@warwick.ac.uk

ABSTRACT

The expected proliferation of rapid EV chargers with more than 100 kW rating will place significant power demand on the UK distribution system. Due to the currently limited headroom in 11kV networks, reinforcement will be costly and disruptive. This paper proposes a medium voltage DC (MVDC) system that bypasses the 33kV/11kV and 11kV/400V AC transformers by transmitting 54 kV DC power directly to the EV charging stations. Additional benefits include the opportunity to reinforce integration of battery storage and photovoltaic sources as well as implement soft-open-points with an MVDC interconnection between asynchronous AC systems at lower voltages. The 33kV AC to 54 kV rectification in this system is proposed to be done by using a 29-level modular multilevel converter (MMC) implemented in 3.3 kV SiC MOSFETs. On the EV side, there will be a 54 kV to 800 V fully isolated DC/DC converter implemented with 3.3 kV SiC MOSFETs on the primary side and 1.2 kV SiC MOSFETs or Schottky diodes on the secondary side. This paper presents converter simulation results demonstrating improved performance in the MVDC system and shows this is only possible with SiC MOSFET technology as the losses using silicon IGBTs make the system less efficient compared to the existing system.

I. INTRODUCTION

In the future when there is significant penetration of EV vehicles, the 11 kV distribution network will increasingly come under the stress of increased EV charging demand [1-3]. The proliferation of ultra-fast chargers for heavy goods vehicles (HGVs) and electric buses will mean the demand of EV chargers capable of above 100 kW charging power will increase. This will require significant upgrades for the distribution network infrastructure, especially the 11 kV/400 V transformers. This paper proposes a medium voltage DC transmission system that transmits power directly from the 33 kV system to the charging station. A conceptual diagram for this is shown in Figure 1 where the MVDC lines are shown in red dashed lines and the conventional AC lines are shown as black lines. There are several advantages to this approach namely

i) This approach avoids the need for upgrading several

- distribution transformers (33kV/11kV & 11kV/400V) since they are bypassed.
- ii) By using MVDC transmission, different points in the low voltage AC system can be interconnected as would be the case using a soft open point (SOP). The advantages of SOPs, which increased improved network fault tolerance and more flexible active/reactive power flow are well known.
 - iii) DC energy storage solutions like batteries and generation systems like photovoltaic can be more easily integrated into the DC transmission system. In addition, it facilitates the integration of off-shore windfarm with less conversion stages.
 - iv) It offers an additional opportunity of interlinking converters from different AC micro-grids.

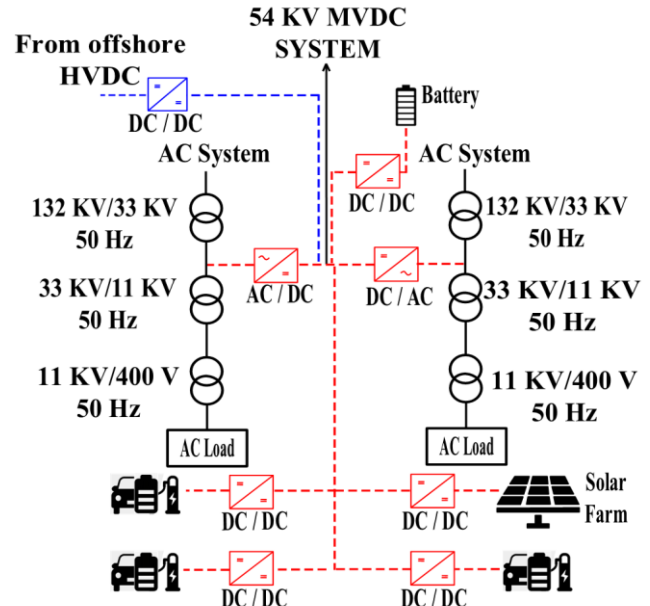

Figure 1. Proposed MVDC Transmission in red

The advantages of MVDC transmission are clear [4, 5], however, what remains to be assessed is the loss performance of the power converters compared to the conventional AC system. This paper implements electrothermal simulations of power converters of the EV chargers in the proposed MVDC system and compares them against those in the conventional AC system. As the voltages are higher and converter topologies are different,

SiC MOSFETs are shown to be at the heart of the MVDC system as it significantly improves on converter efficiency. Section II describes the proposed MVDC system in contrast with the existing AC system, section III introduces the simulation methodology, section IV analyses the results and section V concludes the paper.

II. PROPOSED MVDC SYSTEM

The current technology for EV charging solutions based on the 400 V system uses either the EV onboard chargers (for type 1 and type 2 charging) and an off-board charger for type 3 charging. The charger comprises of a rectifier (for AC to DC conversion) and a dual active bridge (DAB) DC/DC converter for interfacing with the EV battery. The rectifier can currently be implemented as a (i) Vienna rectifier, (ii) an active front end rectifier or (iii) a 12-pulse rectifier. The DC/DC converter is typically implemented using an isolated topology with full bridge primary side converter, an isolating high frequency transformer and either a full bridge diode rectifier (for unidirectional power flow) or another full bridge converter (for bidirectional power flow in vehicle to grid applications). Figure 2 shows a conceptual diagram of this system including the transformers connecting the to high voltage transmission system.

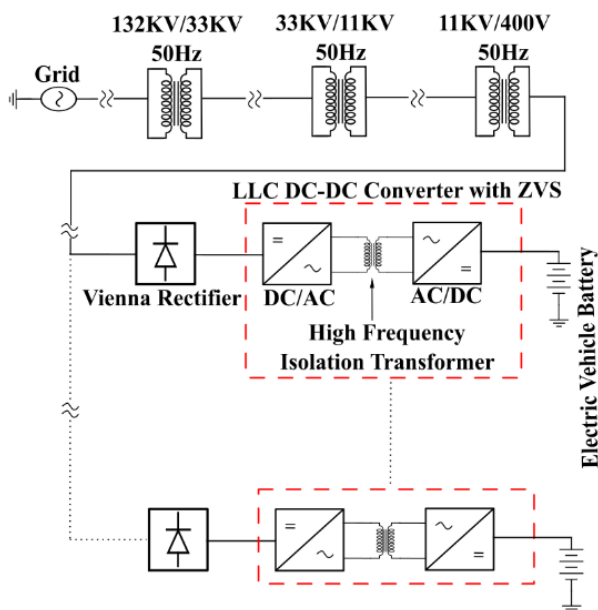

Figure 2. EV charging system from 400V AC mains

In the MVDC system, all the rectification is aggregated to the 33 kV bus. This means that this converter will have significantly higher power rating since it may serve multiple rapid charging stations. Figure 3 shows a conceptual diagram of this MVDC system with the high-power rectifier and the receiving end converters. 54 kV is chosen as the DC transmission voltage since this has been previously demonstrated in an MVDC system [6].

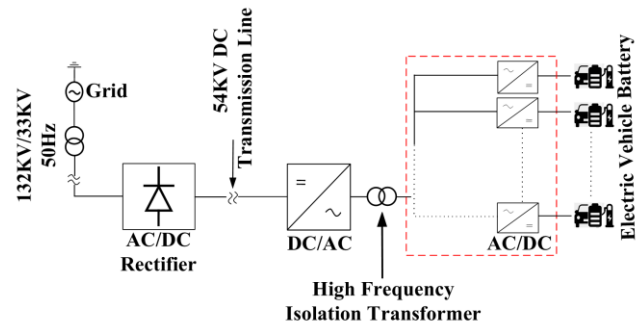

Figure 3. EV Charging with MVDC

Since the DC side voltage is 54 kV and the converters at the EV load end will be required to step down from 54 kV to under 1 kV (for the EV battery), the converter topology applicable is not immediately clear as this has not been demonstrated yet. The high voltage converters can be implemented as

- i) **Two-Level H-bridge Converters with Series Connected Devices:** In this topology, multiple devices will be connected in series for voltage sharing. Each of the six switching blocks of the H-bridge converter will be required to block the entire DC voltage (54 kV). Since the voltage blocking capability of commercially available power devices is limited to 3.3 kV (for SiC MOSFETs) and 6.5 kV (for silicon IGBTs), devices will have to be series connected to share the DC side voltage. This topology was initially commercialized by ABB in its first variant of voltage source converters for HVDC transmission systems. This topology comes with significant challenges including static and dynamic voltage balancing, high electromagnetic stresses that come with fast switching, lack of fault tolerance due to no modularity and large filters for harmonic management.
- ii) **Three level NPC Converters with Series Connected Devices:** In this topology, there are 12 switching units in the converter hence each unit is required to block half the DC link voltage. This means that the number of devices required for series connection in each switching unit is halved thereby easing the difficulties mentioned earlier with 2 level converters. The harmonic output of this converter is better than that of the 2-level converter, however, as there are more switching units the control is more complicated. This converter also lacks modularity hence is also not fault tolerant.
- iii) **Modular Multilevel Converter with Cascaded H-Bridges:** In this topology, the DC link voltage is blocked by a series connection of half-bridge or full bridge converters each operating at a fraction of the total voltage depending on the number of levels. The primary advantage of this topology is that it is highly modular and there is no need for static/dynamic voltage

balancing of series connected devices. The total harmonic distortion (THD) performance of this converter is significantly superior to that of the 2L and 3L NPC converters discussed previously and the switching losses are much lower since very low switching frequency is used compared to the previous converters. Most importantly, the converter is highly modular and is therefore fault tolerant. It is for these reasons that this topology is chosen for implementing the MVDC system for EV chargers. Figure 4 shows the proposed converter implementation for the DC/DC converter at the EV station stepping down from 54 kV to 800 V. The primary side of the high frequency isolation transformer is the MMC single phase inverter and on the secondary side are parallel connected full bridge rectifiers.

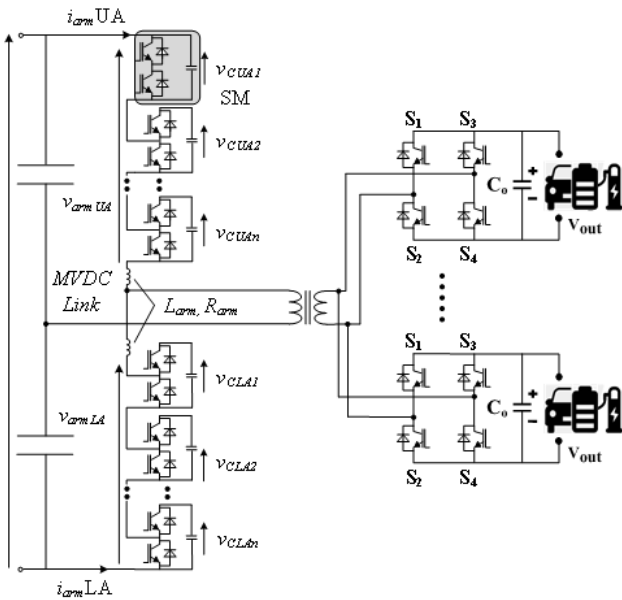

Figure 4. Proposed DC/DC Converter based on MMC Topology

MOSFET based full bridge rectifiers can be used for two reasons. Firstly, to enable bidirectional power flow for vehicle to grid applications and secondly, to improve performance by using synchronous rectification.

III. SIMULATION METHODOLOGY

In this section of the paper, electrothermal simulations are performed on EV chargers in both the conventional low voltage AC system and the MVDC system. To perform accurate loss calculations for the converters in the EV charging systems, it is first necessary to correctly simulate the control system of the converters. Simulations are performed in MATLAB Simulink. Harmonic management of the rectifier is performed by the phase lock loop (PLL). Voltage and current control in the rectifier are

implemented in the DQ reference frame as shown in Figure 5. An LLC converter is used for the DC/DC voltage control. The switching frequency of the converter is selected to ensure zero voltage switching (ZVS) at turn on thereby reducing switching losses significantly.

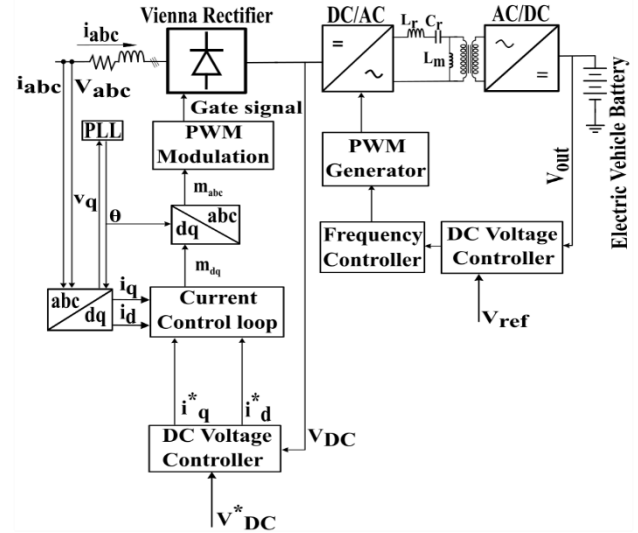

Figure 5. Converter control system implemented in Simulink

However, the turn-off losses of the transistors are still reflected in the converter's performance. To calculate the converter losses, it is necessary for the simulations to be fully electrothermal. This means that the conduction and switching losses of the power devices are used to compute the instantaneous junction temperature using the transient thermal impedance characteristics provided on the device datasheet. A look-up-table (LUT) of losses is used in the simulation so that the losses are temperature dependent. Figure 6 shows the simulation process where the turn-on, turn-off and conduction losses are added into the total losses and used to compute the junction temperature. The switching transients are controlled by the PWM signals generated by the control system.

Table 1 shows the devices used in the simulation of the EV chargers using the 400 V AC system. In the simulations of the EV charger based on the 400 V AC system, 650 V SiC MOSFETs and SiC SBDs are used for the simulations of the Vienna rectifier.

Device	I _{bs} @ 100°C	Datasheet
Vienna Rectifier Devices		
SiC MOSFET	650V/27A	SCT3060AL
Silicon IGBTs	650V/20A	RGT40TS65D
SiC SBD	650V/10A	C3D10065
DC/DC Converter Devices		
SiC MOSFET	1.2kV/24A	C2M0080120D
Silicon IGBT	1.2kV/20A	IHW20N120R5
SiC SBD	1.2kV/16A	C4D10120A

TABLE 1. Devices used in EV Charger Simulations

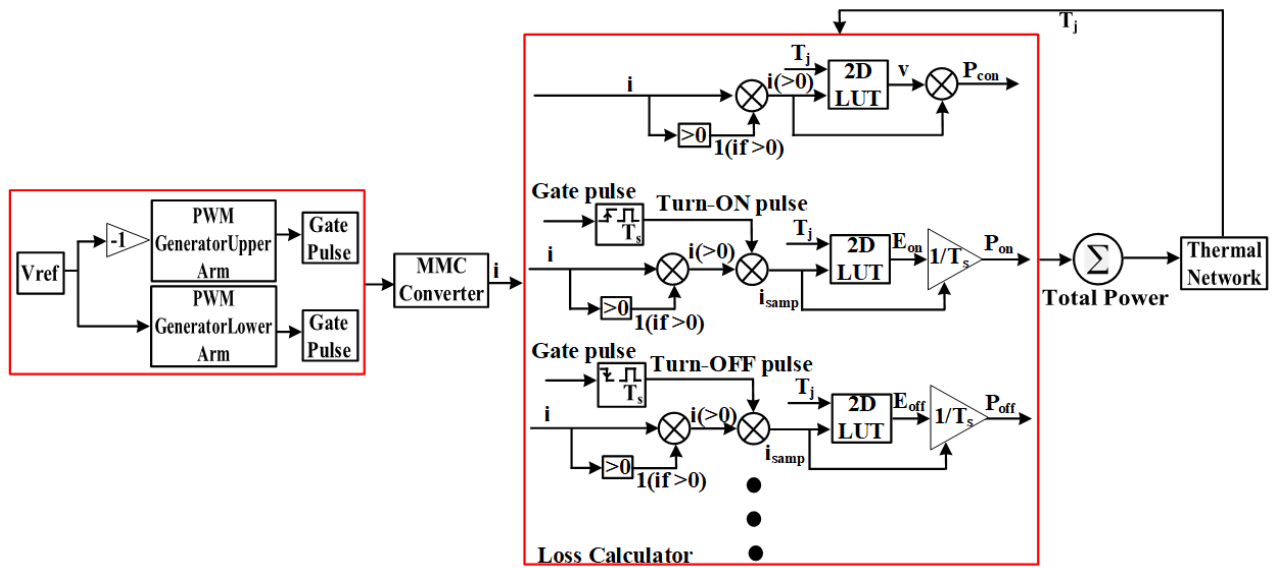

Figure 6. Loss calculation process for Power Converters

1.2 kV SiC MOSFETs, and SiC SBDs are used in the simulations of the DC/DC converter. 1.2 kV SiC Schottky Barrier Diodes are used for the Vienna rectifier front end. To deliver a more compact converter with reduced filter sizes, it is necessary to switch these converters with a high switching frequency (above 50 kHz). A Vienna rectifier based on silicon IGBTs, and silicon PiN antiparallel diodes is also simulated likewise a hybrid solution with silicon IGBTs and antiparallel SiC SBDs.

In the case of the EV chargers used in the MVDC system, two power device technologies as assessed for the implementation. The highest voltage rated SiC MOSFET commercially available is a 3.3 kV SiC MOSFET from GeneSiC with datasheet reference G2R50MT33K. Using this device means that the MMC submodule voltage will be 1928.57 V based on the device using 58% of its rated voltage capacity. This results in a 29 level MMC. If a 6.5 kV silicon IGBT is used, the number of levels of the MMC can be reduced to 17 since each submodule can be implemented with a voltage of 3375 V. The advantage of having a reduced number of levels is reducing the complexity of the MMC control. Since there are no commercially available 6.5 kV SiC MOSFETs, this variant will have to be implemented in silicon IGBTs. For the simulation, a 6.5 kV IGBT from Powerex is used with datasheet reference QIC6508001.

A 1 MW EV charging station is simulated. The peak current demand based on 1 MW charging power is used to determine the number of parallel devices in the simulations since the current conduction capacity of the discrete devices is exceeded.

IV. RESULTS AND ANALYSIS

Figure 7 compares the simulation results of the power losses in the Vienna rectifier in the conventional 400 V AC charging system with those of the MMC converters in the 54 kV MVDC system. As a total charging power of 1 MW is assumed for the EV charging station, this breaks down to twenty-five EV chargers rated at 40 kW each. For the MVDC system, all the rectification is aggregated at the 33 kV bus on the sending end. The converters are simulated with losses from SiC Planar MOSFETs and silicon IGBTs for technological comparison. Simulated losses for the MMC converters implemented in 3.3 kV SiC MOSFETs and 6.5 kV silicon IGBTs are also presented.

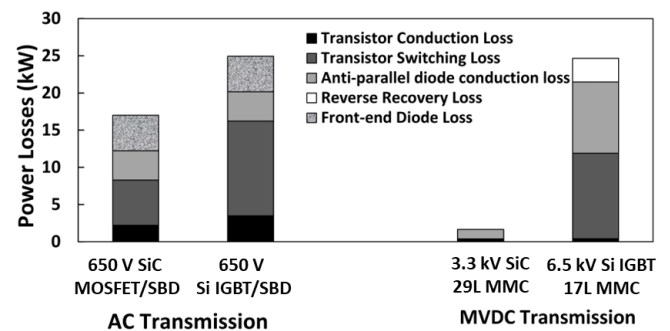

Figure 7. Loss simulation for the rectifiers

The results shown in Figure 7 using the SiC based 29 level MMC converter yields the lowest losses. This is due to the improved conduction and switching performance of SiC MOSFETs over IGBTs and the reduced switching frequencies inherent in MMC operation compared to Vienna rectifiers that operate at high switching frequencies. However, it should be noted that this converter will be significantly more expensive than the

other solutions.

Figure 8 shows the loss simulation results of the DC/DC conversion stage for the EV charging working from AC transmission system and that working from the MVDC system. The losses include the conduction and switching losses of the primary side transistors as well as the total loss of the secondary side rectifiers. For the converter connected to the 400 V AC system, the SiC MOSFET based converter is simulated with 100 kHz switching frequency while the Si IGBT based converter is simulated with 11 kHz (due to limitations of the switching speed of silicon IGBTs). This means that the SiC based Vienna rectifier will be significantly more compact since the isolating transformer will be significantly smaller.

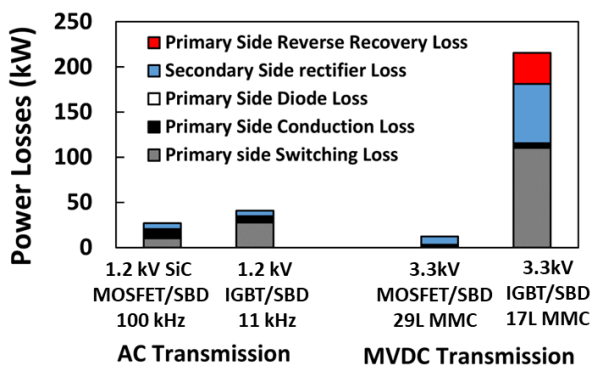

Figure 8. Loss simulation for the DC/DC converters

The MVDC converter on the primary side of the isolated DC/DC converter uses a fundamental frequency of 1 kHz and a switching frequency of 6 kHz to minimize the size of the isolating transformer. Again, the results show that the 29 level SiC based MMC converter demonstrates the best performance as it exhibits the lowest total losses. The 17 level MMC based on Si IGBTs exhibits significantly higher losses due to the switching losses of the Si IGBTs and the switching losses of the 1.2 kV secondary side silicon IGBTs with datasheet reference FZ400R12KE4. As there are no commercially available 6.5 kV SiC MOSFETs, the 17 level converter can only be implemented in Si IGBTs. Figure 9 compares the efficiencies of converters in the AC and MVDC transmission system.

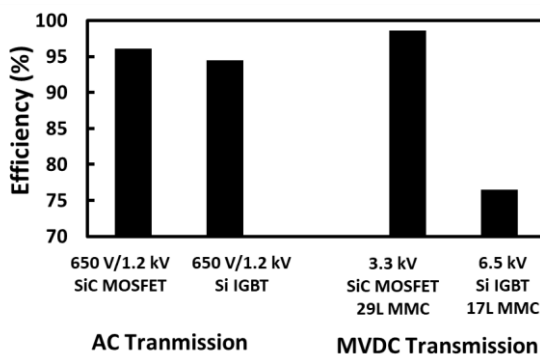

Figure 9. Efficiency comparison

Figure 9 shows that the MMC-MVDC charging system is only more efficient than the existing AC system if SiC MOSFET technology is used.

V. CONCLUSIONS

This paper has proposed MVDC transmission technology as a preferable option for EV chargers over the conventional AC transmission system since it avoids the bottleneck of the lower voltage distribution transformers. Using electrothermal simulations of power converters in Simulink, it has been demonstrated that EV chargers based on MVDC-MMC transmission systems provide the best performance in terms of efficiency when implemented using SiC MOSFET technology. A 54 kV MVDC system for a 1 MW EV charging station was simulated using a 29-L MMC converter based on 3.3 kV SiC MOSFETs and compared to a 17-L MMC converter using 6.5 kV silicon IGBTs. These are compared to EV chargers based on Vienna rectifiers and soft switched DC/DC converters connected to the 400 V AC mains. The results show using MVDC transmission only yields better efficiency performance compared to the existing AC system when implemented in SiC MOSFET technology which is capable of significantly reduced switching losses at higher switching frequencies.

REFERENCES

- [1] J. Antoun, M. E. Kabir, B. Moussa, R. Atallah, and C. Assi, "Impact Analysis of Level 2 EV Chargers on Residential Power Distribution Grids," in *2020 IEEE 14th International Conference on Compatibility, Power Electronics and Power Engineering (CPE-POWERENG)*, 8-10 July 2020 2020, vol. 1, pp. 523-529, doi: 10.1109/CPE-POWERENG48600.2020.9161463.
- [2] Y. Liu, M. Xu, S. Cheng, and F. Li, "Advanced investment in distribution network based on EV penetration," in *CIRED Porto Workshop 2022: E-mobility and power distribution systems*, 2-3 June 2022 2022, vol. 2022, pp. 573-577, doi: 10.1049/icp.2022.0773.
- [3] K. Qian, C. Zhou, M. Allan, and Y. Yuan, "Modeling of Load Demand Due to EV Battery Charging in Distribution Systems," *IEEE Transactions on Power Systems*, vol. 26, no. 2, pp. 802-810, 2011, doi: 10.1109/TPWRS.2010.2057456.
- [4] G. Bathurst, G. Hwang, and L. Tejwani, "MVDC - The New Technology for Distribution Networks," in *11th IET International Conference on AC and DC Power Transmission*, 10-12 Feb. 2015 2015, pp. 1-5, doi: 10.1049/cp.2015.0037.
- [5] Q. Xu, H. Huang, W. Lv, J. Xuan, F. Chen, and J. Wu, "Control strategy of flexible interconnection system in distribution network based on back-to-back MMC-MVDC," in *The 16th IET International Conference on AC and DC Power Transmission (ACDC 2020)*, 2-3 July 2020 2020, vol. 2020, pp. 398-403, doi: 10.1049/icp.2020.0127.
- [6] T. Joseph, J. Liang, G. Li, A. Moon, K. Smith, and J. Yu, "Dynamic control of MVDC link embedded in distribution network: — Case study on ANGLE-DC," in *2017 IEEE Conference on Energy Internet and Energy System Integration (EI2)*, 26-28 Nov. 2017 2017, pp. 1-6, doi: 10.1109/EI2.2017.8245752.