

Robotic ignition systems for oil fields

LAMI, Mohammed, ALBOUL, Lyuba <<http://orcid.org/0000-0001-9605-7228>> and ABED, Issa

Available from Sheffield Hallam University Research Archive (SHURA) at:

<http://shura.shu.ac.uk/30263/>

This document is the author deposited version. You are advised to consult the publisher's version if you wish to cite from it.

Published version

LAMI, Mohammed, ALBOUL, Lyuba and ABED, Issa (2020). Robotic ignition systems for oil fields. In: UKRAS20 Conference: "Robots into the real world" Proceedings. EPSRC UK-RAS Network, 97-99.

Copyright and re-use policy

See <http://shura.shu.ac.uk/information.html>

Robotic ignition systems for oil fields

Mohammed Lami

Materials and Engineering Research
Institute
Sheffield Hallam University
Sheffield, U.K.
b8018683@my.shu.ac.uk

Lyuba Alboul

Materials and Engineering Research
Institute
Sheffield Hallam University
Sheffield, U.K.
l.alboul@shu.ac.uk

Issa Ahmed Abed

Engineering Technical College –
Basrah
Southern Technical University, Basrah,
Iraq
Issaahmedabed@stu.edu.iq

<https://doi.org/10.31256/Ln9Sf6F>

Abstract—In the oil extraction industry, igniting the flare stacks is an essential operation. Oil sites have two kinds of flares, ground flares and flares that installed on towers. The ignition systems generate electrical sparks to burn the gases blowing out of the flares. Due to the permanent high operating temperature and the need for special thermal isolation, classical igniters have low reliability and high cost. In this work, two novel ignition systems have been implemented, the first is the robotic ignition system for ground flares, it utilises a mobile robot which moves toward the flare, avoiding the obstacles in its way and stops after detecting the gas, then it starts igniting the flare before heading to a safe point with no gas and low temperature. The second solution is the automated ignition system to light up the flares on the towers, which is a car that moves on a rail vertically, and begins igniting once it arrives at the tip of the tower, then it comes back to its starting point. As the igniters in both suggested systems are movable, so the system will be exposed to the heat generated by the flame within a very short time, this new feature increases the reliability of the igniter and reduces the complexity and the cost of the system.

Keywords—igniters, microcontrollers, mobile robots, stack flares

I. INTRODUCTION

The work focusses on the oil industry, and particularly on the oil fields where natural gases are occasionally produced during the oil extraction process [1]. These gases are transported to special torches called flare stacks to be burned. Different methods are used to achieve this task, but the most popular method uses the electrical spark to ignite the flares [2]. These sparks are generated by special electrical devices, and then they are delivered to an ignition probe through an electrical cable that is located close to the flare [3]. The parts of the ignition system that are fixed near to the flare are thermally protected using thermal insulators which adds more complexity to the system. However, these systems usually have a short lifetime because of high operating temperature, hence, this reduces the system reliability [4]. The main aim of this research is to implement a new ignition system with a movable igniter, so it can be positioned close to the gas cloud around the flare when it is required to perform the ignition task, and then returns to a safe point away from the high temperature. Consequently, the system complexity will be reduced as no more thermal insulators will be needed, besides, the reliability of the system will be raised because the exposure time of the igniter to the flame will be very short, virtually in terms of seconds. For ground flares, the robotic ignition system has been introduced, which is a robotic car equipped with motorized wheels and different kinds of sensors. With the aid of a special microcontroller and a suitable algorithm, it can move toward the flare stack avoiding the obstacles; the robot uses a gas sensor to measure the density in real-time of the natural gas to determine whether the goal is reached. Once the measured value of the density equals or more than a threshold value stored in the program, the robot decides to stop and start igniting the flare for a while. A fire sensor is utilised detect the flame generated after performing

ignition operation, this helps to verify that the ignition action is completed. Consequently, the robot changes its direction to move away from the flare and searches for a safe point, and of course, it also keeps avoiding the obstacles until the final position is reached. For the flares on towers, an automated ignition system has been suggested, it employs a car which carries the igniter device to be moved on a rail vertically toward the flare and ignite it. The automated car also has a fire sensor to verify the ignition action just like in the robotic ignition system. Both ignition systems mentioned above are designed to work with a secondary robot synchronously, the secondary robot is responsible for opening a gas valve that controls the flowing of the gas from the source (oil well) to the flare stack. The robotic or the automated ignition system firstly orders the secondary robot to open the valve, to ensure the gas is blowing out of the flare before starting the ignition mission.

II. MATLAB/SIMULATION

The artificial potential field (APF) approach has been employed in both systems [5]; in this case, the robot will be guided in the field to the goal (the flare). The mathematical representations for the attractive \vec{F}_{att} and repulsive \vec{F}_{rep} forces are shown in equations (1) and (2) which are retrieved from [5] and [6] respectively.

$$\vec{F}_{att} = K_g \cdot (q - q_{goal}) \quad (1)$$

$$\vec{F}_{rep} = \frac{1}{K_{rep}} e^{-\frac{dist(rob,obs)}{K_{rep}}} \quad (2)$$

The mathematical formulas of robot displacement due to both forces used in MATLAB simulation are given in equations (3) and (4).

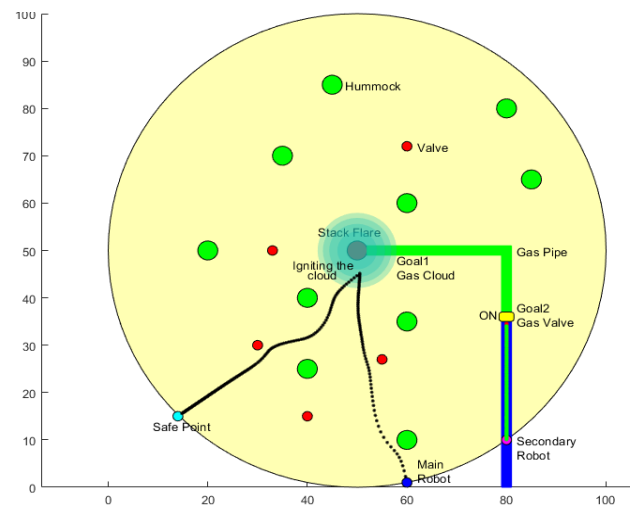

Fig 1: MATLAB simulation of the robotic ignition System

$$dx_{rep} = (robot - Obs_n) \exp \frac{-norm(robot - Obs_n)}{K_{obs_n}} \quad (3)$$

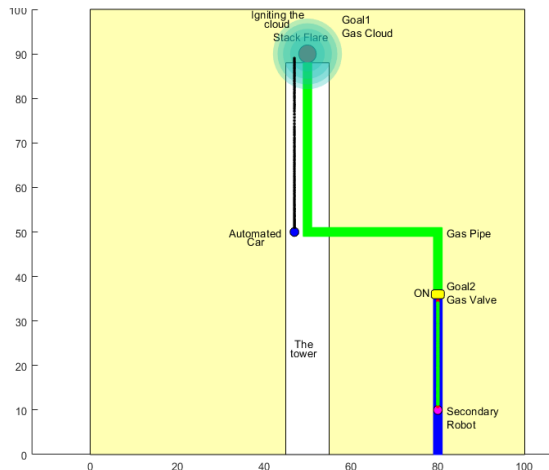

Fig 2: MATLAB simulation of the automated ignition System

Where n is the number of obstacles, $Kobs_n$ is a scaling factor, robot and Obs_n are the positions for the robot and the obstacle.

$$dx_{att} = K_{goal} \frac{(Goal-robot)}{norm(Goal-pos)} \quad (4)$$

Where K_{goal} is a scaling factor, $robot$ and $Goal$ are the positions for the robot and the goal.

Both systems were successfully tested and simulated. The simulation results of the robotic and automated ignition systems are shown in Fig. 1 and Fig. 2.

III. IMPLEMENTATION

The robotic ignition system (the robotic car) has been prototyped as shown in Fig 5, using the embedded system shown in Fig. 3. The two microcontrollers control robot's motors, obstacle avoidance and ignition action based on the real-time data obtained from the equipped sensors. The automated ignition system (the automated car on the rail) has been prototyped as shown in Fig. 5, using the embedded system shown in Fig. 4. The PLC control car's motors and ignition action based on the real-time data obtained from the equipped sensors.

IV. RESULTS, DISCUSSION AND CONCLUSION

To sum up, the output of this work is the implementation of the two ignition systems. The first one is the robotic ignition system which is designed to serve the ground flares in oil fields. Secondly, the automated ignition system has been introduced as a solution for the flare stacks on the towers in oil fields. In the classical ignition systems, the direct exposure of some components to the flame for long periods reduces the operating lifetime of the ignition device, the heat usually damages these components and then they need to be replaced. Moreover, in some cases, there is no opportunity for service between major shutdown and this leads to a reduction in system reliability [4]. Due to the high operating temperature, the igniter and other parts of the system are protected using special insulators which bear temperature up to 1100 C° [7], and this increases the complexity and the cost of the system dramatically. The unique property of the suggested ignition systems in this work is that the end terminal (the part of the system that responsible for delivering the spark to the flare) is not fixed at the position of the flare, but it is movable, it is utilised only when it is needed to ignite the gas cloud, so it will be exposed to the fire within a short time in terms of few seconds during ignition operation. Hence, this feature could

reduce system complexity and cost as the igniter no longer need a high thermal isolation. Since the exposure time of the igniter to the hazardous temperature becomes short, the igniters will be more reliable with long lifetime. However, although the exposure time becomes short, the external parts of the robot and the automated car should be chosen to bear the high temperature within ignition operation. In addition, the time needed to accomplish the ignition operation by the two suggested systems will be longer as compared with current ignition systems, it depends on the speed of the robot, number of obstacles in its way and how much the ground is sloped. Furthermore, the algorithm used in implementing the robotic ignition system assumes that the robot always succeed in igniting the flare at the first time, but practically it may fail if the amount of the gas is low even if its density is high, a future work, an extended algorithm is needed to execute several attempts that may be required to complete the task.

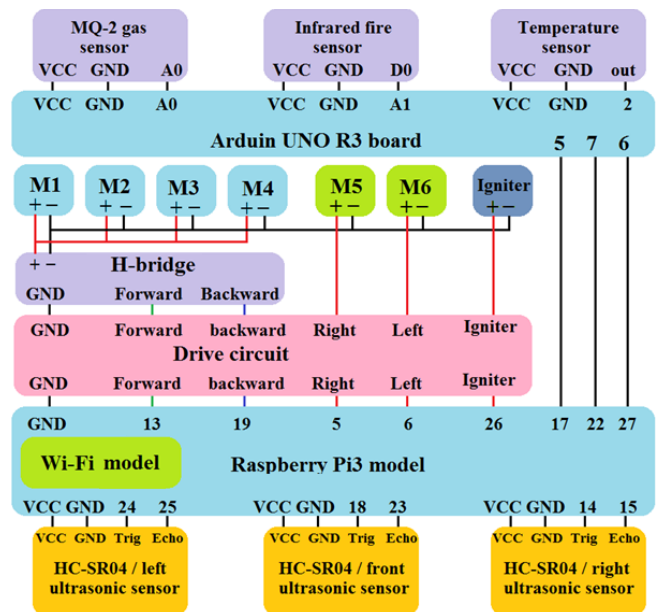

Fig 3: The detailed wiring diagram for the robotic ignition system

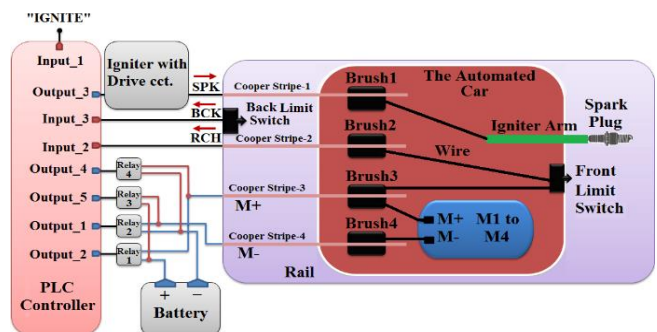

Fig 4: The detailed wiring diagram for the robotic automated system

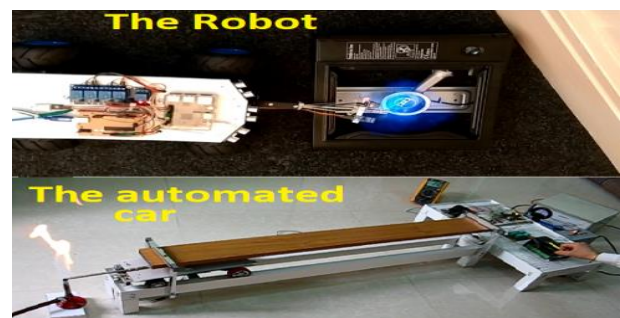

Fig 5: The prototyped robot and the automated car

References

- [1] Eman, "GAS FLARING IN INDUSTRY: AN OVERVIEW," Petroleum & Coal ISSN 1337-7027, December 2015.
- [2] Profire Energy, "FLARE STACK IGNITER," 2015. [Online]. Available: https://www.profireenergy.com/product_documents/FSL_Manual_and_Install_Guide_0.1_print.pdf.
- [3] Honeywell, "Two-rod Pilot Burner/Igniter-Sensor," 2017. [Online]. Available: <https://customer.resideo.com/resources/Techlit/TechLitDocuments/69-0000s/69-0768.pdf>.
- [4] Argo, "Electronic Spark Ignition," 2019. [Online]. Available: <http://www.argoflars.com/research/introduction/pilot-burners-ignition-systems/electronic-spark-ignition/>.
- [5] R. Siegwart, I. Nourbakhsh and D. Scaramuzza, Introduction to autonomous mobile robots, vol. 2nd ed., 2011.
- [6] D. S. Neculescu, E. Pruner and e. al., "Self-organizing robot formations using velocity potential fields commands for material transfer," 2014.
- [7] Kraus, Kurt, Richmond, Dusty, Jennings, Jay and Bietto, Stefano. USA Patent 8986000, 2015.