

**Fault identification-based voltage sag state estimation using artificial neural network**

LIAO, Huilian <<http://orcid.org/0000-0002-5114-7294>> and ANANI, Nader

Available from Sheffield Hallam University Research Archive (SHURA) at:

<http://shura.shu.ac.uk/17392/>

---

This document is the author deposited version. You are advised to consult the publisher's version if you wish to cite from it.

**Published version**

LIAO, Huilian and ANANI, Nader (2017). Fault identification-based voltage sag state estimation using artificial neural network. *Energy Procedia*, 134, 40-47.

---

**Copyright and re-use policy**

See <http://shura.shu.ac.uk/information.html>



9th International Conference on Sustainability in Energy and Buildings, SEB-17, 5-7 July 2017,  
Chania, Crete, Greece

## Fault Identification-based Voltage Sag State Estimation Using Artificial Neural Network

Huilian Liao <sup>a\*</sup>, Nader Anani <sup>b</sup>

<sup>a,b</sup>*Electrical, Electronic and Control Engineering, Sheffield Hallam University, UK*

---

### Abstract

This paper presents an artificial neural network (ANN) based approach to identify faults for voltage sag state estimation. Usually ANN cannot be used to abstract relationship between monitored data and arbitrarily named fault indices which are not related at all logically in numerical level. This paper presents a novel approach to overcome this problem. In this approach, not only the networks are trained to adapt to the given training data, the training data (the expected outputs of fault indices) is also updated to adapt to the neural network. During the training procedure, both the neural networks and training data are updated interactively. With the proposed approach, various faults can be accurately identified using limited monitored data. The approach is robust to measurement uncertainty which usually exists in practical monitoring systems. Furthermore, the updated fault indices are able to suggest the difference of the impact of various faults on bus voltages.

© 2017 The Authors. Published by Elsevier Ltd.  
Peer-review under responsibility of KES International.

*Keywords:* Voltage sag state estimation; artificial neural network; fault indices; power quality; state estimation.

---

---

\* Corresponding author. Tel.: +44 (0)114 225 3607; fax: +44 (0)114 225 4449.

*E-mail address:* [huilian.liao@shu.ac.uk](mailto:huilian.liao@shu.ac.uk)

## 1. Introduction

Recently, the increased awareness of power quality (PQ) issues has led to more research focused on PQ state estimation (PQSE) which covers different types of analysis in PQ area. Voltage sags as one of the most critical power quality problems has attracted great attention in the last decade due to the substantial financial losses to many utilities and industries and frequent disruptions to industrial processes and malfunction of electronic equipment caused by voltage sags [1]. Driven by the need to compare the PQ performance among utility companies or among various feeders, voltage sag state estimation (VSSE) was developed to estimate sag characteristics at unmonitored nodes and used for sag assessment. Accurate state estimation of voltage sags allows the operators to be aware of the network performance and develop appropriate network enhancement strategy [2].

Various techniques have been explored for VSSE in literature. Fault position based methods determine the voltage sag magnitude at buses in the network for faults occurring in previously selected fault positions [3]. Since most likely, these methods are not designed to pinpoint the exact fault position, probability based methods have been investigated for VSSE in literature [4]. With the condition identified by the monitoring data, the characteristics of voltage sags at non-monitored buses can be estimated by finding a set of fault positions which are likely to cause the residual voltages. For every possible fault position identified, the residual voltage at all non-monitored buses can be determined by simulating the fault at such a position. The residual voltage can be calculated as a weighted average of all potential residual voltages. Monitor reach area (MRA) method, as one of the most popular and preferred sag monitoring method, is widely used to register voltage sags by faults [5]. MRA defines the region of the network where a monitor is able to register voltage sags caused by faults. A single MRA matrix represents the area of the network where a monitor can detect and capture the voltage sags originated by faults with specific characteristics, such as type, location, and fault resistance, and taking place under particular system conditions such as network topology and generation schedule. The MRA matrix is built for each type of fault and for a number of given voltage thresholds. In this approach, a considerable number of MRA matrices should be built in order to study a reasonable number of fault scenarios. Furthermore, a series of voltage thresholds should be selected and set in advance before being used to build MRA matrix. The effectiveness of sag performance estimation at non-monitored buses obtained from MRA based methods is greatly dependent on the comparison between the actual voltages and the voltage thresholds. Especially with the presence of measurement uncertainty which is very common in practical operation, the information derived from the comparison between the deviated measured voltage residuals and fixed voltage thresholds may mislead and result in inaccurate estimation.

Artificial neural network (ANN), inspired by biological nervous system, is an interconnected assembly of simple processing elements, units or nodes, which allows the network to adapt to and store a set of training patterns through the inter-unit connection weights. ANN is widely applied to various areas such as prediction, curve fitting and clustering etc. It has been also used for solving problems in various areas of power system, ranging from system planning to operation as well as analysis/modeling [6].

This paper proposes a fault position based VSSE method, which employs ANN to register faults, i.e., to associate faults with the voltages at monitored buses. The proposed approach adopts a novel approach for training neural network in ANN. Different from general ANN based methods, the proposed approach updates/modifies the training data simultaneously as the neural network evolves. Given limited monitored data, the proposed approach is able to identify the faults accurately, and allow the voltage sags at unmonitored buses being estimated. The approach eliminates the necessary of setting voltage thresholds in MRA based methods, and has the merit of being robust to measurement uncertainty.

## 2. Problem Description

### 2.1. VSSE by Identification of Fault Location

Sag monitoring system-level monitoring and estimation are concerned in the study. It intends to estimate the overall power quality of the entire system. This approach requires monitoring usually at a large number of sites and estimating the voltages at sites without monitors. Since it is economically unfeasible to monitor many sites, only a

limited number of monitors can be located in a network. It is desired that the voltage sags can be estimated accurately with limited monitors placed.

Since the voltage sags are mainly caused by short-circuit faults, any monitoring system whose objective is the localization of faults can be used for sag estimation. For fault position based sag estimation approaches, the estimation procedure involves finding a fault location that produces voltages and currents that most closely match the measurements from the few available monitors [7]. With the faults identified, the voltage residuals at all buses can be analysed. When different types of faults are considered, the allocation for each type of fault can be identified separately using limited monitors. Then, an array of monitors covering all the responses obtained by the algorithm is analyzed.

## 2.2. Artificial Neural Network (ANN)

The structure of an ANN is illustrated in Fig. 1, in which hidden layers and an output layer are presented. For each layer there are an input vector, a weight matrix  $W$ , a bias vector  $b$ , a sum operator, a transfer function (TF)  $f$  and an output vector. The weighting matrix weighs the input elements, the bias vector biases the weighed inputs via the sum operator, the sum operator gathers the weighed inputs and the biases to produce an intermediate variable for the TF, and the TF produces the final output of the layer. The output of the hidden layer is the input of the output layer. The weight matrix and biases are determined through training process which adapts the network to match the inner-pattern of the given input data. Further description of this type of ANN can refer to [8-10].

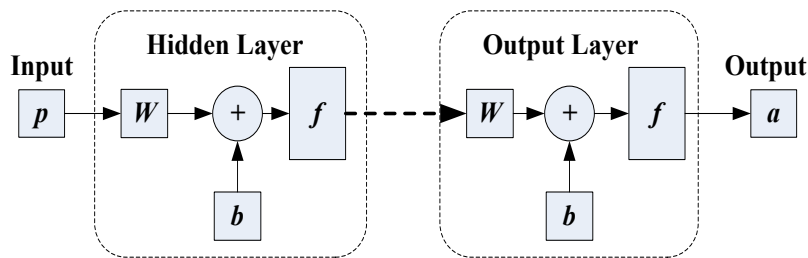

Fig. 1. Structure of an ANN

## 3. Problem Description

The problem to be solved in the study is to associate voltage residuals at the monitored buses with the corresponding faults. The fault indices could be, and often are named arbitrarily, i.e., two close fault indices could represent two faults occurring at two locations which are geographically far away from each other, or two completely different types of faults, depending on the way of numbering them. Usually the fault indices can be named as integral numbers. Assuming there are 24 faults in the network, then the fault indices can be defined as integral number from 1 to 24. Usually the patterns abstracted by neural networks present the numeric relationship between inputs and outputs, i.e., the weighted contribution of input's proportionality or differentials to outputs. Taking load forecasting as example, neural network can be used to associate the inputs of temperature and historical load demand with the future load demand. It is straightforward that the load demand is affected by the numeric values of inputs such as temperature, therefore neural network can be used to abstract the relationship between the temperature and load demand, e.g., whether the load demand tends to increase or decrease when the temperature is increased or decreased. For the problem to be solved here (i.e., associate the voltages with integral fault indices), it is unlikely that the neural network can be trained to link the voltage residuals with the arbitrary integer numbers (1 to 24). Taking Fig. 2 as an example, it can be seen that the bus voltages caused by Faults F1 and F3 are similar, while the voltage caused by Fault F2 is much different. Logically, the Faults F1 and F3 should be numbered in a way that they have close fault indices, in order to enable neural network to learn and abstract the logical connection between the fault indices and corresponding voltages. However, the fault indices initially are numbered arbitrarily

without taking into account and compare the difference of bus voltages caused by different faults. The arbitrarily named fault index itself is not numerically related to the values of inputs. It suggests that the monitored voltage residuals and the arbitrary integral fault indices have no connection at all in numerical levels thus it is unlikely that the inner patterns that link the inputs (monitored voltage residuals) with the output (fault indices) can be found.

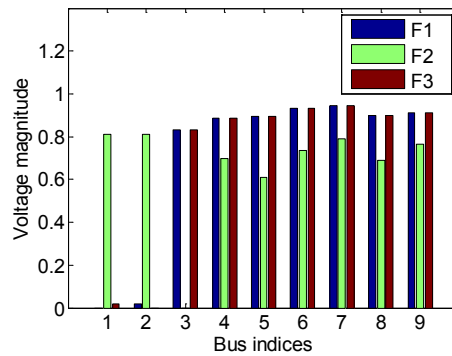

Fig. 2. Illustration of the voltage residuals by three different faults.

The issue raised above is solved by the procedure of adjusting fault indices during training the neural network. Instead of only adapting the neural network to match the training data (i.e., voltage residuals and the original fault indices), the procedure of network training also adapts the training data to facilitate the neural network which evolves during training. During network training procedure a series of new fault indices will be generated to replace the original fault location indices.

The procedure of training the network is illustrated in Fig. 3. Firstly, a series of potential faults are identified and assigned with fault indices. Assuming there are  $N_F$  faults in the test network, the faults can be named from 1 to  $N_F$ . In step 1 in Fig. 3, each potential fault is simulated to generate its corresponding voltage residuals at monitored buses. The training data consists of the monitored voltage residuals as the inputs  $x$  and the corresponding fault indices as the expected outputs. With the initialized neural network in step 2, the training data, including the input and expected outputs, are applied to train the neural network and generate an updated neural network. At this point, the updated network cannot provide satisfactory mapping between the monitored voltage residuals and original fault indices. In step 4, the trained neural network is simulated with the same inputs  $x$ , and generate outputs denoted as  $y'$ . In step 5, the fault indices are re-numbered based on the ranking of  $y'$  in ascending order. In this way, the fault indices are re-numbered by taking into account the magnitude of the simulated output of the trained neural network. The evolution of the fault indices are illustrated in Table 1. In generation 2 in Table 1, the fault indices  $y$  are updated based on the ranking of the simulated output  $y'$ . It can be seen that in generation 2 the updated fault indices  $y$  are still integer numbers. With the same inputs  $x$  and the updated expected fault indices  $y$ , the neural network is re-trained in step 6. With the same inputs  $x$  the latest updated neural network is simulated, and the output is denoted as  $y'$  in step 7. If  $y'$  converges to the expected output  $y$ , the iteration will terminate. Otherwise, the fault indices will be updated by setting  $y=y'$ , which is again employed as the expected fault indices and used to re-train the neural network. It can be seen from Table 1 that from generation 3, the fault indices are adjusted to decimal numbers rather than integer numbers. In steps 6-7 in Fig. 3, the fault indices and the neural networks are updated simultaneously until the simulated outputs of the latest updated neural network are very close to the modified (expected) fault indices. Once the simulation converges, the procedure outputs the latest neural network and the modified fault indices generated in the last generation as illustrated in Table 1. The whole procedure here is to obtain the neural network and the logical numeric indices which are associated with the fault locations.

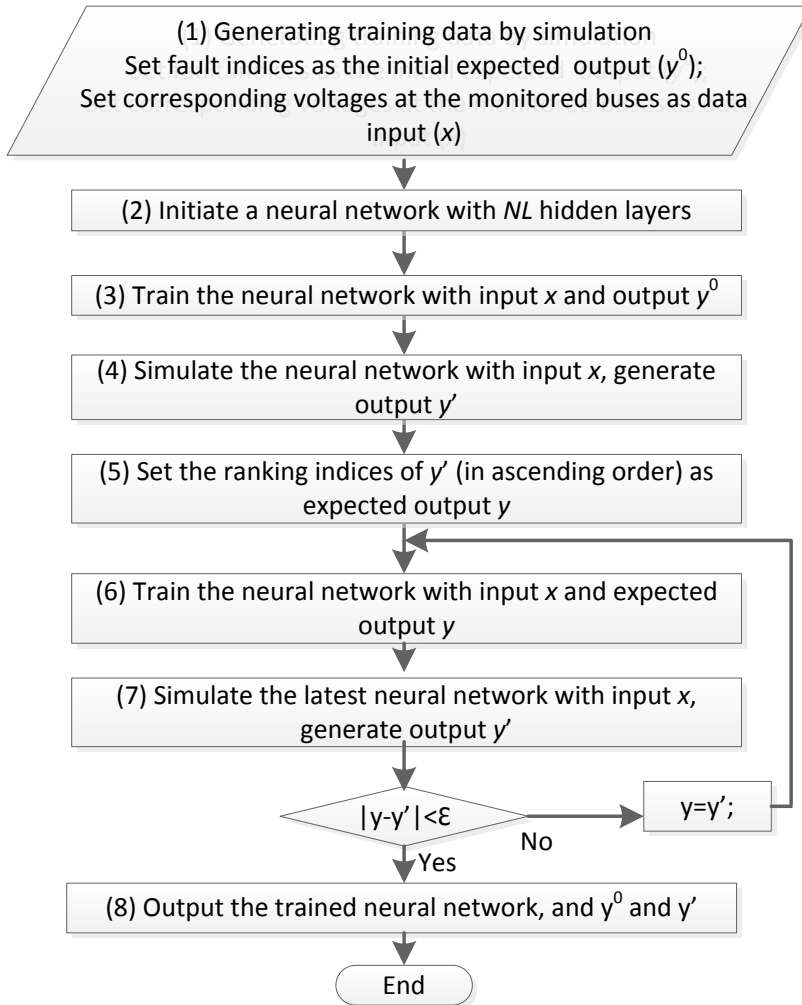

Fig. 3. Procedure of obtaining the neural network and corresponding representative fault indices.

Table 1. Illustration of the evolution of fault indices during training procedure.

Gen.	Procedure	Evolution of fault indices		
		Fault 1	Fault 2	Fault 3
1	Initial Fault indices	1	2	3
2	Set fault indices as the ranking of $y'$ in step 5	3	1	2
3	Set fault indices as $y'$	2.82	1.34	2.11
...	Set fault indices as $y'$	...	...	...
$N_G$	Set fault indices as $y'$	2.65	1.46	2.34

Given the monitored voltage residuals, the final neural network can be simulated, and the output of the neural network is used to compare with all fault indices of the last generation, and the one which is closest to the output of the neural network will be selected and its corresponding fault can be identified.

#### 4. Simulation Results

The proposed approach was tested on IEEE Reliability Test system (RTS), as presented in Fig. 4, which consists of 24 buses, 33 lines, 10 generators, and 5 transformers. The system is used as a benchmark system for power flow analysis, reliability analysis, fault analysis, and transient stability, etc. [11]. In total 24 faults at different locations are considered in the simulation. In the simulation, three sag monitors are employed and placed at buses 18, 19 and 20 respectively.

The original fault indices are set arbitrarily from 1 to 24 as given in the  $x$ -axis in Fig. 5. The 24 faults are simulated separately and the voltage residuals at buses 18, 19 and 20 are recorded. The initial neural network is assigned with five hidden layers. The data used to train the neural network consists of the voltage residuals at monitored buses (as inputs) and the corresponding fault indices (as the expected outputs). The procedure converges after three generations, and the adjusted fault indices are presented in Fig. 5.

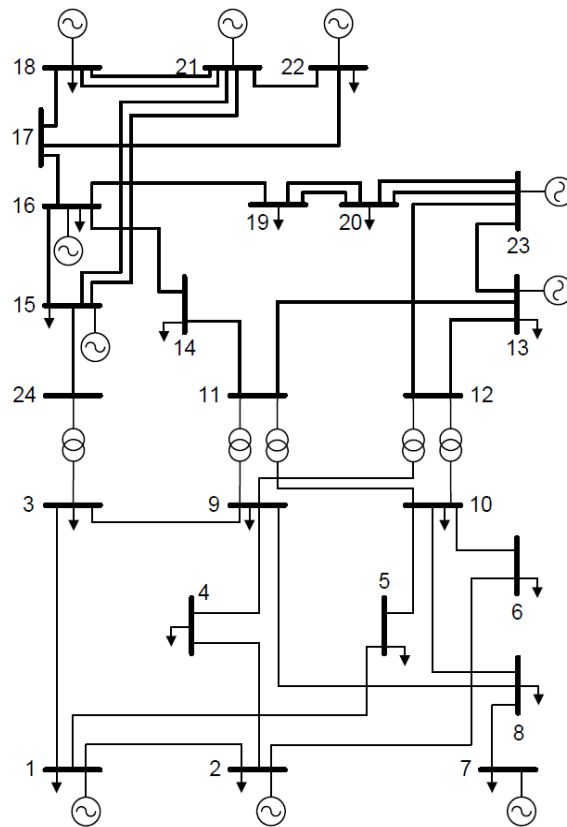

Fig. 4. IEEE Reliability Test system (RTS)

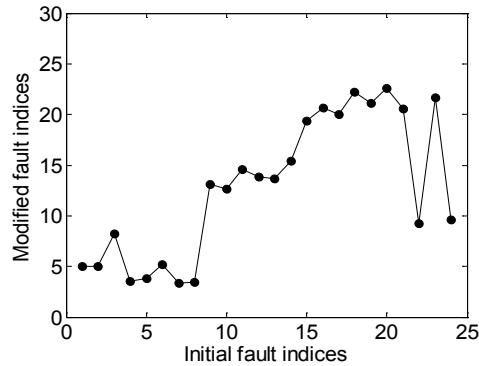

Fig. 5. Initial and adjusted fault indices.

#### 4.1. Uncertainty of the monitored voltage residuals

Uncertainties exist in measurements of various network parameters including voltage  $U$ . Real measurements can be characterized by their own ranges of measurement errors which are primarily determined by the corresponding measurement devices. The uncertainty of the measurement should be considered when evaluating the performance of fault location. The simulation here adopts the accuracy classes of 0.2 of voltage transformers (VTs) base on IEC60044-2 [12]. For a given percentage of the maximum allowed deviation (i.e., tolerance) from the mean  $\mu$ , the standard deviation of the measurement error can be derived based on  $\sigma = \mu \times \%error / (3 \times 100)$  [13]. Randomly generated measurement errors are added to the simulated voltage residuals at monitored buses. The deviated voltage residuals are served as inputs to the trained neural network for estimating fault indices. In this cast, all 24 faults can be accurately identified with the deviated monitored voltages. Given the uncertainty of the monitored data, the simulated outputs of the neural network (i.e., the estimated fault indices) for different faults are given in Fig. 6. It can be seen that even with reasonable measurement errors, the fault indices can be accurately estimated, and the fault location can be identified accurately.

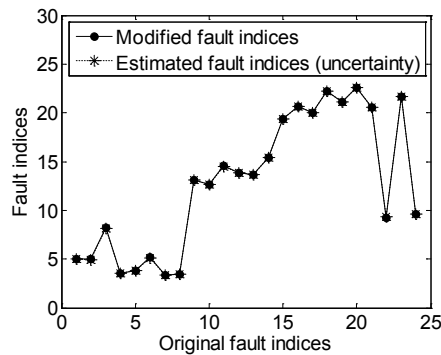

Fig. 6. Fault indices estimated by deviated monitored voltages.

Employing the deviated monitored voltages, the voltage residuals at monitored buses and those estimated at unmonitored buses for faults 1 and 2 respectively are presented in Fig. 7. It can be seen that the impact of these two faults on the voltage residuals at buses are very similar, which explains why the adjusted fault indices for faults 1 and 2 are very similar, as shown in Fig. 5. This also suggests that from the modified/adjusted fault indices obtained by the proposed approach, the impacts on bus voltages by various faults can be distinguished by fault indices themselves.



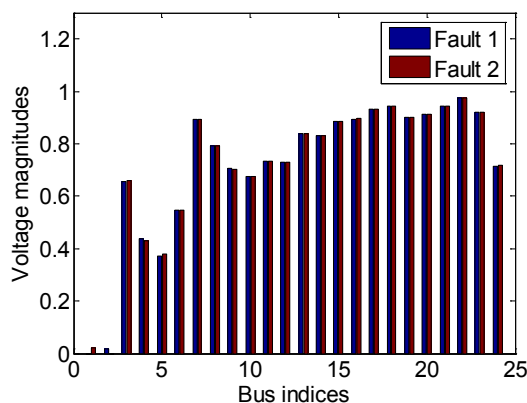

Fig. 7. Monitored and estimated voltages for faults 1 and 2 respectively.

## 5. Conclusions

This paper presents a fault position based voltage sag state estimation using artificial neural network. Different from general neural network training procedure in which the neural network is trained to adapt to the training data, both the neural networks and training data are updated simultaneously during training procedure in the proposed approach. The fault indices numbered arbitrarily originally are adjusted to a series of numerical values which can reveal the difference of their impact on voltage residuals. Using this approach, the faults can be accurately identified using limited monitored data even when measurement uncertainty is taken into account. With this approach, the faults can be identified accurately using only one neural network, rather than employing a considerable number of matrices to register various types of faults. The future work will include the application of the proposed method for optimal sag monitor placement.

## References

- [1] H.L. Liao, Sami Abdelrahman, Yue Guo, Jovica V. Milanović, Identification of Weak Areas of the Network Based on Exposure to Voltage Sags—Part I: Sag Severity Index. *IEEE Trans on Power Del.*, vol. 30, no. 6, pp. 2392-2400, 2015.
- [2] W. Bin, X. Wilsun, P. Zhencun. Voltage sag state estimation for power distribution systems, *IEEE Trans Power Syst.*, vol. 20, pp. 806-812, 2005.
- [3] IEEE Recommended Practice for the Design of Reliable Industrial and Commercial Power Systems - Redline. *IEEE Std 493-2007 (Revision of IEEE Std 493-1997) - Redline*, (2007) 1-426.
- [4] M. T. Aung, J. V. Milanović. Stochastic prediction of voltage sags by considering the probability of the failure of the protection system. *IEEE Trans Power Del.*, vol. 21, pp. 322-329, 2006.
- [5] G. Olguin, F. Vuinovich, M.H.J. Bollen. An optimal monitoring program for obtaining Voltage sag system indexes. *IEEE Trans. on Power Del.*, 21 (2006) 378-384.]
- [6] M. Tarafdar Haque, A.M. Kashtiban. Application of Neural Networks in Power Systems; A Review. *World Academy of Science, Engineering and Technology* 6 2007, 643-647
- [7] R.C. Dugan, M.F. McGranaghan, S. Santoso, H.W. Beaty. *Electrical Power Systems Quality*. 2nd ed., McGraw-Hill, 2003.
- [8] H. K. Long, Y.Y. Hsu, and Y. Chien-Chuen. Short term load forecasting using a multilayer neural network with an adaptive learning algorithm. *IEEE Trans.on Power Syst.*, vol. 7, pp. 141-149, 1992.
- [9] K. Gurney. *An introduction to neural network*. University College London Press, 1997.
- [10] H. Demuth, M. Beale, M. Hagan. *MATLAB Neural network toolbox user's guide*, ed, 2009.
- [11] Q.B. Dam, A.P. Sakis Meliopoulos, G.T. Heydt, A. Bose. A breaker-oriented, three-phase IEEE 24-substation test system. *IEEE Trans on Power Del.*, 25 (2010) 59-67.
- [12] IEC 60044-2:2003. *Instrument transformers – Part 2. Inductive voltage transformers*, ed, 2003.
- [13] R. Singh, B. C. Pal, R. B. Vinter. Measurement placement in distribution system state estimation. *IEEE Trans. Power Syst.*, vol. 24, pp. 668-675, 2009.