

Non-linear model calibration for off-design performance prediction of gas turbines with experimental data

TSOUTSANIS, Elias <<http://orcid.org/0000-0001-8476-4726>>, LI, Yi-Guang, PILIDIS, Pericles and NEWBY, Mike

Available from Sheffield Hallam University Research Archive (SHURA) at:

<https://shura.shu.ac.uk/16808/>

This document is the Accepted Version [AM]

Citation:

TSOUTSANIS, Elias, LI, Yi-Guang, PILIDIS, Pericles and NEWBY, Mike (2017). Non-linear model calibration for off-design performance prediction of gas turbines with experimental data. *The Aeronautical Journal*, 121 (1245), 1758-1777. [Article]

Copyright and re-use policy

See <http://shura.shu.ac.uk/information.html>

Nonlinear model calibration for off-design performance prediction of gas turbines with experimental data

Elias Tsoutsanis^{1,2} Yi-Guang Li³ Pericles Pilidis³ Mike Newby⁴

¹ Emirates Aviation University, School of Engineering, Dubai, UAE

² Sheffield Hallam University, Department of Engineering and Mathematics, Sheffield, UK

³ Cranfield University, School of Aerospace, Transport and Manufacturing, Cranfield, Bedford, UK

⁴ Manx Utilities, Isle of Man, UK

Abstract

One of the key challenges of the gas turbine community is to empower the condition based maintenance with simulation, diagnostic and prognostic tools which improve the reliability and availability of the engines. Within this context, the inverse adaptive modelling methods have generated much attention for their capability to tune engine models for matching experimental test data and/or simulation data. In this study, an integrated performance adaptation system for estimating the steady state off-design performance of gas turbines is presented. In the system, a novel method for compressor map generation and a genetic algorithm based method for engine off-design performance adaptation are introduced. The methods are integrated into PYTHIA gas turbine simulation software, developed at Cranfield University and tested with experimental data of an aero derivative gas turbine. The results demonstrate the promising capabilities of the proposed system for accurate prediction of the gas turbine performance. This is achieved by matching simultaneously a set of multiple off-design operating points. It is proven that the proposed methods and the system have the capability to progressively update and refine gas turbine performance models with improved accuracy, which is crucial for model-based gas path diagnostics and prognostics.

Nomenclature

$a_{i,j}$	= weighting factor of OF
ETA	= isentropic efficiency
ETA_a	= elliptical coefficient for the semi-major axis
ETA_b	= elliptical coefficient for the semi-minor axis
ETA_{b1-3}	= efficiency sub-coefficients
ff	= engine fuel flow (kg/s)
k	= number of measurable parameters
l	= number of operating points
N	= compressor shaft speed
OF	= objective function
\mathbf{p}	= performance parameter vector
$\mathbf{p}_{M_{i,j}}$	= measurable parameters
$\mathbf{p}_{i,j}$	= predicted parameters
P	= total pressure (atm)
PR	= pressure ratio
PR_{1-2}	= pressure ratio sub-coefficient
PR_b	= elliptical coefficient for pressure ratio
T	= total temperature (K)

\mathbf{u} = ambient and operating condition vector
 UW = power output (W)
 \mathbf{x} = independent component characteristics vector
 WAC = corrected mass flow rate
 \bar{W} = mass flow rate (kg/s)/elliptical coefficient
 WAC_a = mass flow rate
 W_{1-2} = mass flow sub-coefficient

Greek

η = efficiency

Subscripts

$1-8$ = engine stations (see Fig. 8),
 amb = ambient
 DP = design point
 g = exhaust gas
 s = surge
 SM = surge margin
 th = thermal

Introduction

The continuously stringent environmental regulations imposed on the gas turbines for propulsion and power applications, along with the competitive market environment, has triggered diverse challenges. One of these challenges is the development of multi-fidelity, accurate and reliable engine performance models which leads towards a better understanding of the behavior of these highly nonlinear and complex machines. A successful operation and maintenance strategy for gas turbine assets depends on the informed decisions that gas turbine operators make according to the available information from condition monitoring, diagnostic and prognostic tools. An example of the impact that the engine models may have on the implementation of these decision making tools can be found in the General Electric's latest Digital Twin™ technology [1]. One of the engaging tasks of the gas turbine community is the continuous development of engine modelling techniques [2-6] for improving the accuracy of performance simulation [7-9], diagnostics [10,11] and prognostics [12-14].

Gas turbines have to operate at any point between idle and full power at various ambient, altitudes and/or flight conditions. The off-design performance behavior of each gas turbine engine is determined by the behavior of its key gas path components represented by their "characteristic maps". These maps represent the interrelationships among the component performance parameters such as pressure ratio, air mass flow rate, isentropic efficiency and shaft rotational speed. The characteristic maps may be obtained from a long and expensive development effort by original equipment manufacturers (OEM) and remain, apart from a few examples in the literature, proprietary information.

Given the proprietary nature of the compressor maps and their emphasized importance in engine performance estimation, the gas turbine research community has addressed this limitation by utilizing generic component maps

and then tuning and scaling the maps in order to match the actual engine performance obtained from engine tests. In recent years, the topic of inverse modelling with experimental data has generated much attention [15,16] for several scientific disciplines since it enables a fast and accurate representation of a system's behavior for a wide range of operating conditions and applications.

One of the most common inverse mathematical modelling processes for estimating the gas turbine performance is the multiple point performance adaptation. This process may involve adaptation of an engine model in order to match simultaneously a set of measurements taken from a service engine at off-design conditions. Stamatis et al [9] introduced such a method of adapting an engine model through an optimal set of scaling factors applied to the compressor map after an optimization process. The work of Kong and Ki [17] suggested a scaling method based on system identification and later on a compressor map generation method through genetic algorithm (GA) [18]. Lo Gatto et al [19] used a GA method to search for an optimal set of scaling factors based on rig test data at a single off-design point. This method was further developed by Wang et al [20] and Li et al [21] by seeking an optimal set of scaling factors to compromise the accuracy of multiple off-design point test data. Recently, Li et al [22,23] proposed a variable scaling factors for multiple off-design operating points in order to perform a nonlinear multiple point adaptation.

In contrast to the existing scaling techniques [9, 17-24] this paper proposes a non-linear compressor map modelling and generation method based on engine off-design test data. The compressor map generation procedure is analytical and can therefore capture nonlinear distribution of speed lines and efficiency contours. This method is then integrated into an engine model and a GA based performance adaptation system for multiple off-design performance simulation. It should be noted that both the compressor map generation method and the inverse modelling optimization process have integrated into PYTHIA gas turbine software platform which has been utilized by Manx Utilities for improved condition based maintenance of a combined cycle power plant. Two test cases are conducted for an aero derivative industrial gas turbine engine to demonstrate the capability of the proposed method, in comparison with an earlier adaptation approach [19], in the estimation of off-design performance of the engine.

Methodology

Map Representation

The first step of the methodology involves the development of a mathematical model to present a compressor characteristic map. Among a limited number of compressor maps available in the literature, the characteristic map of GE's LM2500 gas turbine [25] is taken as an example for this analysis. This map has been digitized and reproduced as seen in Fig. 1. The input ambient operating conditions of this compressor map refer to ISA conditions of $T_a=288.15$ K and $P_a=101.325$ kPa.

The form of the compressor map shown in Fig. 1 represents graphically the interrelationships of all component characteristic parameters, namely mass flow rate WAC , pressure ratio PR , isentropic efficiency ETA and referred shaft rotational speed N . In order to facilitate the interpretation of such compressor characteristics by an engine simulation program two separate maps may be presented, one for PR - WAC relationship and the other for ETA - WAC relationship. Normally, such compressor characteristics may be represented in either a graph or a table. To represent compressor maps in a more generic form for the purpose of performance adaptation, a new method is introduced as follows.

It is assumed that the compressor map speed lines are segments of a set of ellipses

$$\left(\frac{x-x_c}{a}\right)^2 + \left(\frac{y-y_c}{b}\right)^2 = 1, \quad (1)$$

where (x_c, y_c) are the coordinates of the center of the ellipse. In case of the PR - WAC map it may be assumed that the center of the ellipse is fixed at the origin $(0, 0)$. Therefore Eq. (1) becomes

$$\left(\frac{WAC}{WAC_a}\right)^2 + \left(\frac{PR}{PR_b}\right)^2 = 1, \quad (2)$$

where WAC_a and PR_b denote the semi-major and semi-minor axes of the ellipse. These coefficients correspond to the points at which each curve meets the x and y -axis when $PR=0$ and $WAC=0$, respectively.

A similar fitting approach has been employed for the second form of the compressor map which represents the relationship between mass flow and isentropic efficiency. As before, it is assumed that each efficiency line belongs to an elliptic curve, with its center fixed at $(x_c, 0)$, which is given by

$$\left(\frac{WAC-x_c}{ETA_a}\right)^2 + \left(\frac{ETA}{ETA_b}\right)^2 = 1. \quad (3)$$

The only difference in our approach for this form of the map is the fact that the coordinate of the ellipse's center in x -axis (x_c) is assumed to coincide with the mid-point of air mass flow range for each line of constant speed, as shown in Fig. 3. The range of the mass flow rate is known from the PR - WAC map; hence the only unknown parameter that needs to be determined is the coefficient ETA_b .

The proposed mathematical representation method has been tested for fitting the characteristic map of GE's LM2500 and the resulted map for the PR - WAC relationship is shown in Fig. 4. Taking into account that 50 operating points have been selected for fitting each map the mean prediction error for the PR - WAC and the ETA - WAC maps is 0.2% and 0.1%, respectively.

Map generation

The second step of the methodology deals with the mathematical analysis of the proposed elliptical coefficients and more specifically their variation with respect to the rotational speed N . This analysis is carried out in order to establish the mathematical relationships for controlling and generating the compressor map shape. Starting off with PR - WAC map the coefficient WAC_a may be expressed as an exponential function of relative shaft speed

$$WAC_a = WAC_{DP} \cdot W_1 \cdot N^{W_2}, \quad (4)$$

where W_1 and W_2 are the sub-coefficients of this exponential function and WAC_{DP} denotes the mass flow rate at design point conditions.

The elliptical coefficient PR_b may be similarly expressed by an exponential function of relative shaft speed

$$PR_b = PR_{DP} \cdot PR_1 \cdot N^{PR_2}, \quad (5)$$

where PR_1 and PR_2 are the sub-coefficients of the equation and PR_{DP} denotes the design point pressure ratio.

The parameter PR_s , schematically illustrated in Fig. 2, denotes the pressure ratio at the surge point of a speed line. Assuming a reasonable surge margin (SM) of 20% (i.e. $SM=0.2$), then PR_s can be determined as

$$PR_s = PR_{DP}(SM + 1). \quad (6)$$

The mass flow rate corresponding to the surge point of the same speed line can be determined by the elliptical equation

$$WAC_s = \sqrt{WAC_a^2 \cdot [1 - (PR_s/PR_b)^2]}. \quad (7)$$

The sub-coefficients W_1 , W_2 , PR_1 and PR_2 determine the pressure ratio and mass flow rate within the specified range of 50% up to 115% of compressor relative shaft speed N . A similar procedure has been followed for the map that represents the ETA - WAC relationship. For this form of the map it was assumed that the isentropic efficiency can be accurately approximated by a quadratic function as

$$ETAb = ETA_{DP}(ETA_{b_1} \cdot N^2 + ETA_{b_2} \cdot N + ETA_{b_3}), \quad (8)$$

where ETA_{b_1} , ETA_{b_2} and ETA_{b_3} are the sub-coefficients of the equation and ETA_{DP} denotes the design point isentropic efficiency. This is because the contour of ETA_b represents the peak efficiency of different speed lines on the ETA - WAC graph shown in Fig. 3 and the distribution of the peak efficiency curve is close to a quadratic curve.

To evaluate the impact of each sub-coefficient, a sensitivity analysis is performed. This sensitivity analysis examines the effect that a -10% drop of each sub-coefficient has on the pressure ratio, the mass flow rate and the isentropic efficiency of the compressor. As shown in Fig. 5 the pressure ratio has an increased sensitivity to sub-coefficients PR_1 and PR_2 . A sensitivity of similar magnitude is also noticed for the mass flow rate to

the sub-coefficients W_1 , W_2 . Finally, the isentropic efficiency is solely affected by the sub-coefficients ETA_{b1} , ETA_{b2} and ETA_{b3} . It is also worth noting that a 10% drop in ETA_{b2} leads to -25% deviation in efficiency, a fact that emphasizes the amplified influence that this sub-coefficient has. It follows that the efficiency depends very much on ETA_{b2} which shows that the relationship is mainly linear and to a second degree nonlinear (ETA_{b2}). The sensitivity analysis can serve as a guide for setting the upper and lower bounds of these sub-coefficients when these are used for a constrained optimal coefficient searching process.

The total number of sub-coefficients for this analysis is seven, as summarized in Table 1. Tuning these sub-coefficients through an optimization algorithm allows the modification of the generated compressor map in a nonlinear fashion. As a result, an engine model could be adapted to real engine off-design performance by modifying the compressor maps using engine test data.

Performance Adaptation

Performance adaptation is an inverse mathematical process with the objective of tuning/adapting an engine model so as to match the observable measurements of an engine. Generally, the measurable engine performance parameters are gas path measurements such as temperatures and pressures represented by a vector \mathbf{p} . The measurable engine performance parameters are a function of ambient and operating condition parameters represented by a vector \mathbf{u} (P_{amb} , T_{amb} , "handle") and the component characteristics represented by a vector \mathbf{x} as follows:

$$\mathbf{p} = f(\mathbf{x}, \mathbf{u}). \quad (9)$$

Note that the "handle" parameter refers to the control parameter of the engine which might be shaft rotational speed, shaft power output, Turbine Entry Temperature (TET) or any other quantity. The "handle" is an input to the engine model and determines the power level of the engine.

Now the objective of the performance adaptation is to modify the component characteristics vector \mathbf{x} in order to match the measurable gas path parameters vector \mathbf{p} at off-design operating conditions. To assess the accuracy of the adaptation the difference between the predicted measurements \mathbf{p} by the engine model and the observed measurements of the engine \mathbf{p}_m is evaluated by an objective function (OF)

$$OF = \sum_{j=1}^l \sum_{i=1}^k \left| \frac{p_{i,j} - p_{M_{i,j}}}{p_{M_{i,j}}} \right| \cdot 100, \quad (10)$$

where $p_{M_{i,j}}$ are the values of the observed measurements and $p_{i,j}$ are the corresponding predicted measurements. The parameter k denotes the total number of measurable parameters and l the number of off-design operating points used in the adaptation process.

GA optimization

For the minimization problem of the objective function a GA optimizer is developed and implemented. GA is an adaptive heuristic search algorithm based on the evolutionary needs of natural selection and genetics [21]. The GA initially generates a population of a large number of possible solutions, called strings, of the compressor map's sub-coefficients over a specified range. It then calls the performance simulation module in PYTHIA software to predict the off-design performance in order to calculate the fitness of the strings within the population.

$$GA \text{ Fitness} = \frac{1}{1+OF}. \quad (11)$$

Crossovers and mutations may be used to generate extra strings to replace worse strings in the population in order to improve the average fitness of the whole population. Such a process of GA search is repeated until the specified maximum number of generations has been reached. Then the best string of the whole population, i.e. the best set of compressor map sub-coefficients with the highest fitness is selected as the solution of the performance adaptation. The quality of each set of sub-coefficients within the population is assessed by the fitness criterion of Eq. 11. A value of fitness approaching 1 indicates a good set while a value approaching 0 represents a poor set. The flow chart of such an adaptation process is shown in Fig. 6. The result of this process is an updated and more accurate engine model that can be used for future diagnostic analysis of the engine. It should be noted that the turbine map has not been utilized for this adaptation process due to the fact that the turbine is operating at choking conditions for a wide operating range. Moreover, the variation of turbine pressure ratio with respect to the corrected mass flow rate can be approximated by a horizontal line.

Application, Results and Discussions

The accuracy of the proposed method has been tested for a GE LM2500+ aero derivative gas turbine engine, shown in Fig. 7, that operates in Manx Utilities' (MU) combined cycle power plant in the Isle of Man, UK.

The GE LM2500+ engine, which is a derivative of GE's CF6 jet engine core, is used for land and marine power applications. It has a 17 stage compressor [27], with the first seven stages having variable stator vanes. The engine is also configured with a single annular combustor (SAC), a two stage high pressure turbine and a two stage free power turbine of Nuovo Pignone. The layout of the developed engine model is shown in Fig. 8. The bleed flow at the discharge of the compressor is used for cooling the high pressure turbine.

The design point performance specification of the GE LM2500+ engine is summarized in Table 2 [28].

The engine model input and the measurable parameters for the off-design performance adaptation are summarized in Tables 3 and 4, respectively. The power output is set as the handle/control parameter of the engine.

A design point performance adaptation [29] for the model at 30 MW is carried out in order to match the available design point performance of the engine. Once the engine model has been properly updated for the selected design point an initial compressor map is generated. Then the off-design performance adaptation as described in the following test cases is applied to modify the initial compressor map in a nonlinear way so as to match multiple off-design measurable parameters while keeping the same design point.

Two test cases have been carried out to test the effectiveness of the developed methods and system. The objective of the first test case is to match a set of "deck data" that are measurements generated by an engine model, which uses a default compressor map shape. The power output is reduced from 30MW to 27MW at incremental steps of -0.5 to -1.0 MW. The accuracy of the proposed adaptation is tested by generating and tuning a compressor map through the GA optimizer in order to match the "deck data".

The objective of the second test case is to examine the performance of the proposed method for real service engine measurements that are designated as "test data" and obtained from the LM2500+ engine operating in the MU's combined cycle power plant. The earlier linear scaling adaptation technique developed by Li [19] and the proposed map generation adaptation are employed for this test case and are going to be referred to as "earlier" and "new" adaptation methods, respectively. For both methods the engine model configuration was the same. A summary of the adaptation test cases is presented in the Table 5.

Initially the upper and lower bounds for the sub-coefficients W_1 , W_2 , PR_1 , PR_2 , ETA_{b_1} , ETA_{b_2} and ETA_{b_3} were adjusted several times during the trial adaptation process to find appropriate searching domains for the sub-coefficients. During this initial phase, a default map shape available from PYTHIA software has been used for testing the validity of the proposed method. This testing phase enabled the selection of the upper and lower bounds of the sub-coefficients which were identical for both test cases. The final bounds used for the adaptation are shown in Table 6.

The GA parameters for this study are shown in Table 7, where 20 GA generations with a population size of 50 were used. The probabilities of crossover and mutation are 0.35 and 0.3, respectively. Normally the mutation rate ranges from 10% to 20% for providing a good balance between the searching space and the convergence of the optimizer. However, in this study the mutation rate selected is intentionally higher at 30% in order to provide additional searching space to the algorithm since the upper and lower bounds for W_1 , PR_1 and ETA_{b_2} is wide. Once convergence is accomplished, one may reduce the mutation probability, limit the range of the two sub-coefficients and rerun the optimizer in order to improve the prediction accuracy of the engine model.

Test Case 1

The results of the off-design performance adaptation in this test case are shown in Fig. 9, illustrating that all the selected gas path measurements are matched very well with an accuracy spanning from -0.01 % up to 0.33 for the entire range of power output in concern. The measurements corresponding to the compressor exit namely P_3 and T_3 are the ones that present the lowest prediction accuracy compared to the other measurements. The reason for this is due to the fact that both computed measurements rely heavily on the generated shape of the compressor map. For high pressure ratio compressors, the curves in the high speed region of the map (i.e. close to 100% referred speed N) are quite steep and almost vertical. This characteristic limits the searching space of the GA optimizer and therefore the interpolation capability of the proposed elliptical method. However, it should be noted that the general trend of the adaptation process is characterized by prediction of high accuracy.

Test Case 2

In the second test case a set of "test data" from MU's power plant is used. A series of tests have been performed in MU's power plant to obtain off-design steady state data for one of the gas turbines.

One of these tests involved the shutdown of the engine for a prolonged period of 3 hours at specified power increments. For this test, the engine was allowed sufficient time to stabilize at each power setting in order to examine its steady state behavior at off-design conditions.

A sample of this "test data" selected for the adaptation can be seen in Fig. 10. Data correction and reduction techniques have been employed in order to select the appropriate set of operating points for this multiple-point adaptation application which is schematically represented in Fig. 11. The above process has been facilitated by the large amount of data available from the engine test. Specifically, since the engine had sufficient time to stabilize at each power setting the operating points corresponding to the final stages of each setting have been selected. It follows that the operating points of the engine before changing the power demand represent the most suitable and representative samples of data for steady state off-design performance.

Averaged measurement samples at several stabilized power levels are used for the off-design performance adaptation.

The results for both the new and earlier [19] adaptation methods can be viewed from Figs. 12 and 13, where the predicted off-design measurable parameters P_3 and T_3 are plotted against the engine power output. The same level of accuracy has been achieved for all the selected measurements, but only P_3 and T_3 are presented here since they had the lower prediction accuracy in Test Case 1. It is evident from Figs 12 and 13 that the new adaptation method is superior compared with the earlier method [19] in terms of prediction accuracy.

The earlier adaptation method has a maximum error in temperatures equivalent to 8K to 10K and is characterized by an over prediction of the measurable parameters. The error distributions from the new adaptation method follow the same trend where its maximum prediction error occurs at the lowest power setting of 0.9.

Typically for a single point adaptation with a population size of 50 it takes around 12 seconds per generation. The multi-point adaptation with the same size of population takes slightly longer time to get a solution as shown in Table 8. In other words, it takes around 48 seconds per generation in Case 1 and 21 seconds per generation in Case 2. The maximum fitness achieved using the new adaptation method is 0.91 in test case 1 and 0.94 in test case 2.

The convergence plot of the GA fitness is shown in Fig. 14. It is evident from Fig. 14 that the initial fitness of the GA is 0.6 and it takes about 8 generations to reach a fitness value of 0.9. Given that the computation time per generation is 21 seconds, the optimizer needs 168 seconds to reach the aforementioned level of fitness.

The prediction accuracy of the proposed adaptation is superior to the reference method as seen from the fitness of the genetic algorithm which is 27% more accurate. The time taken for the developed adaptation to converge is greater than that of the earlier adaptation. The reason for this is that there are seven sub-coefficients controlling the compressor map generation, opposed to only three for the earlier adaptation, which in turn increases the searching space of the optimizer.

The setting window of PYTHIA's new adaptation method and the adaptation results window for such a test case are shown in Figs. 15 and 16, respectively. The user has to set the handle of the gas turbine which is the power output for this engine model and then the target measurements should be selected.

The results window provides the GA parameters and the simulated measurements results with their corresponding errors as shown in Fig. 16. Once the

adaptation is completed, a comparison of the initial and final compressor map shape generated after design-point and off-design adaptation, respectively are shown in Figs. 17 and 18. The graphical representation of the generated compressor map can serve as a tool for 'on the spot' judgments of the engine's performance.

The shape of the compressor maps generated depend firstly on the set of the sub-coefficients optimized through GA and secondly on the number of computed points that each curve has. The proposed adaptation method has an improved accuracy. Another advantage of this method is its unique feature of the compressor map generation that has the potential for a wide range of applications.

Conclusions

In this paper, an advanced performance adaptation system is introduced that aims to improve the accuracy of gas turbine performance models at off-design conditions. This is achieved by introducing a new compressor map generation method which introduces a set of parameters to control the shape of the characteristic maps in a nonlinear way. The set of parameters that control the shape of the map are optimized by a genetic algorithm in order to match as accurate as possible the gas path measurements of an engine at off-design conditions.

Application of the developed approach to a model aero derivative gas turbine has proved the following.

- Its comparison to a reference adaptation method demonstrates that it offers around 27% improved prediction accuracy for the engine model.
- The computational time for a typical multiple operating point adaptation case with a population size of 50 is slightly higher than the reference adaptation method. In other words, it takes around 21 seconds per generation for the new method compared with 15 second per generation for the reference method.

The proposed nonlinear adaptation method is capable of generating and tuning compressor maps of an engine performance model through implementation of available engine test data. It is a very useful tool for supporting model based gas path diagnostics and prognostics applications that rely on accurate gas turbine performance models.

Acknowledgements

The financial support provided by Manx Utilities and the Engineering and Physical Sciences Research Council (EPSRC) is greatly acknowledged.

References

- [1] Transforming GE to Digital Industrial, Available at: (https://www.ge.com/sites/default/files/ge_webcast_presentation_03012016_0.pdf) (accessed 26.07.16)
- [2] VOLPONI, A. Gas Turbine Engine Health Management: Past, Present, and Future Trends, *J. Engineering for Gas Turbines and Power*, Vol. 136, 5, p. 051201, 2014
- [3] TAHAN, M., TSOUTSANIS, E., MUHAMMAD, M. and KARIM, Z. A. Performance-based health monitoring, diagnostics and prognostics for condition-based maintenance of gas turbines: A review. *Applied Energy*, 198, 122-144, 2017
- [4] BALA, A., SETHI, V., GATTO, E.L., PACHIDIS, V. and PILIDIS, P. PROOSIS—A Collaborative Venture for Gas Turbine Performance Simulation Using an Object Oriented Programming Schema, *ISABE 2007 Proceedings*, ISABE 1357, 2007
- [5] VISSER, M. and BROOMHEAD, M. GSP, a generic object-oriented gas turbine simulation environment, In *ASME Turbo Expo 2000: Power for Land, Sea, and Air*, pp. V001T01A002-V001T01A002. American Society of Mechanical Engineers, 2000.
- [6] FREDERICK, D.K., DECASTRO, J.A. and LITT, J.S. User's guide for the commercial modular aero-propulsion system simulation (C-MAPSS), 2007
- [7] TSOUTSANIS, E., MESKIN, N., BENAMMAR, M. and KHORASANI, K. Dynamic performance simulation of an aeroderivative gas turbine using the matlab/simulink environment, in *Proc. ASME IMECE*, IMECE2013-64102, vol. 4, San Diego, USA, 2013, p. V04AT04A050.
- [8] VISSER, M., KOGENHOP, O. and OOSTVEEN, M. A generic approach for gas turbine adaptive modeling, *J. Engineering for Gas Turbines and Power*, 128, no. 1 (2006): 13-19.
- [9] STAMATIS, A., MATHIOUDAKIS, K. and PAPAILIOU, K. Adaptive simulation of gas turbine performance, *J. Engineering for Gas Turbines and Power*, Issue 2, paper, 112, 1990
- [10] LI, Y.G. Performance-analysis-based gas turbine diagnostics: A review, *Proceedings of the Institution of Mechanical Engineers, Part A: Journal of Power and Energy* 216.5 (2002): 363-377.
- [11] LI, Y.G. and SINGH, R. An advanced gas turbine gas path diagnostic system—PYTHIA, In *XVII International Symposium on Air Breathing Engines*, Munich, Germany, Paper No. ISABE-2005-1284. 2005.
- [12] LI, Y.G. and NILKITSARANONT, P. Gas turbine performance prognostic for condition-based maintenance, *J. Appl. Energy*, vol. 86, no. 10, pp. 2152-2161, 2009
- [13] TSOUTSANIS, E., MESKIN, N., BENAMMAR, M. and KHORASANI, K. A dynamic prognosis scheme for flexible operation of gas turbines, *J. Appl. Energy*, vol. 164, pp. 685-701, 2016.
- [14] TSOUTSANIS, E. and MESKIN, N. Derivative-driven window-based regression method for gas turbine performance prognostics. *Energy*, 128, 302-311, 2017
- [15] HAYES, R., R. DWIGHT, AND S. MARQUES. Reducing parametric uncertainty in limit-cycle oscillation computational models, *The Aeronautical Journal*, 2017
- [16] KENNEDY, M. C., AND O'HAGAN, A. Bayesian calibration of computer models. *Journal of the Royal Statistical Society: Series B (Statistical Methodology)*, 63(3), 425-464, 2001
- [17] KONG, C., KI, J. and KANG, M. A new scaling method for component maps of gas turbine using system identification, *J. Engineering for Gas Turbines and Power*, Vol. 125(4), pp. 979-985, 2003
- [18] KONG, C., KHO, S. and KI, J. Component map generation of a gas turbine using genetic algorithms, *Journal of Engineering for Gas Turbines and Power*, 128(1):92-96, 2006
- [19] LO GATTO, E., LI, Y.G. and PILIDIS, P. Gas turbine off-design performance adaptation using a genetic algorithm, *Proceedings of the ASME Turbo Expo*, 2006
- [20] WANG, L., LI, Y.G., HUANG, K. and FENG, X. Gas Turbine Off-Design Performance Model Improvement for Diagnostics, *The Sixth International Conference on Condition Monitoring and Machinery Failure Prevention Technologies*, Paper No. CM-MFPT-0149-2009, 2009
- [21] LI, Y.G., MARINAI, L., LO GATTO, E., PACHIDIS, V. and PILIDIS, P. Multiple Point Adaptive Performance Simulation Tuned to Aerospace Test-Bed Data, *J. Propul. Power*, 25(3), pp. 635-641, 2009
- [22] LI, Y.G., ABDUL GHAFIR, M.F., WANG, L., SINGH, R., HUANG, K. and FENG, X. Nonlinear multiple points gas turbine off-design performance adaptation using a genetic Algorithm, *J. Engineering for Gas Turbines and Power*, Vol.133, 2011
- [23] LI, Y.G., ABDUL GHAFIR, M.F., WANG, L., SINGH, R., HUANG, K., FENG, X. and ZHANG, W. Improved Multiple Point Non-Linear Genetic Algorithm Based Performance Adaptation Using Least Square Method, *J. Engineering for Gas Turbines and Power*, Vol. 134, pp.031701, March 2012.
- [24] YANG, Q., LI, S. and CAO, Y. A new component map generation method for gas turbine adaptation performance simulation. *Journal of Mechanical Science and Technology*, 31(4), 1947-1957, 2017
- [25] KLAPPROTH, J., MILLER, M. and PARKER, D. Aerodynamic development and performance of the cf6-6/lm2500 compressor, *International Symposium on Air Breathing Engines*, 4th, Orlando, pages 243-249, 1979
- [26] GOLDBERG, D.E. *Genetic Algorithms in Search, Optimization and Machine learning*, Addison-Wesley, New York, 1989
- [27] WADIA, R., WOLF, D.P. and HAASER, F.G. Aerodynamic design and testing of an axial flow compressor with pressure ratio of 23.3:1 for the lm2500+ gas turbine, *Journal of Turbomachinery*, 2002
- [28] The LM 2500+ Engine, Available at: (<http://www.geaviation.com/engines/docs/marine/datasheet-lm2500plus.pdf>) (accessed 26.07.16)

- [29] LI, Y.G., PILIDIS, P. and NEWBY, M.A. An adaptation approach for gas turbine design-point performance simulation., *J. Engineering for Gas Turbines and Power*, Vol. 128, no. 4 (2006): 789-795.

Figure 1 LM2500 Compressor Performance Map [Click here to download Figure](#) 

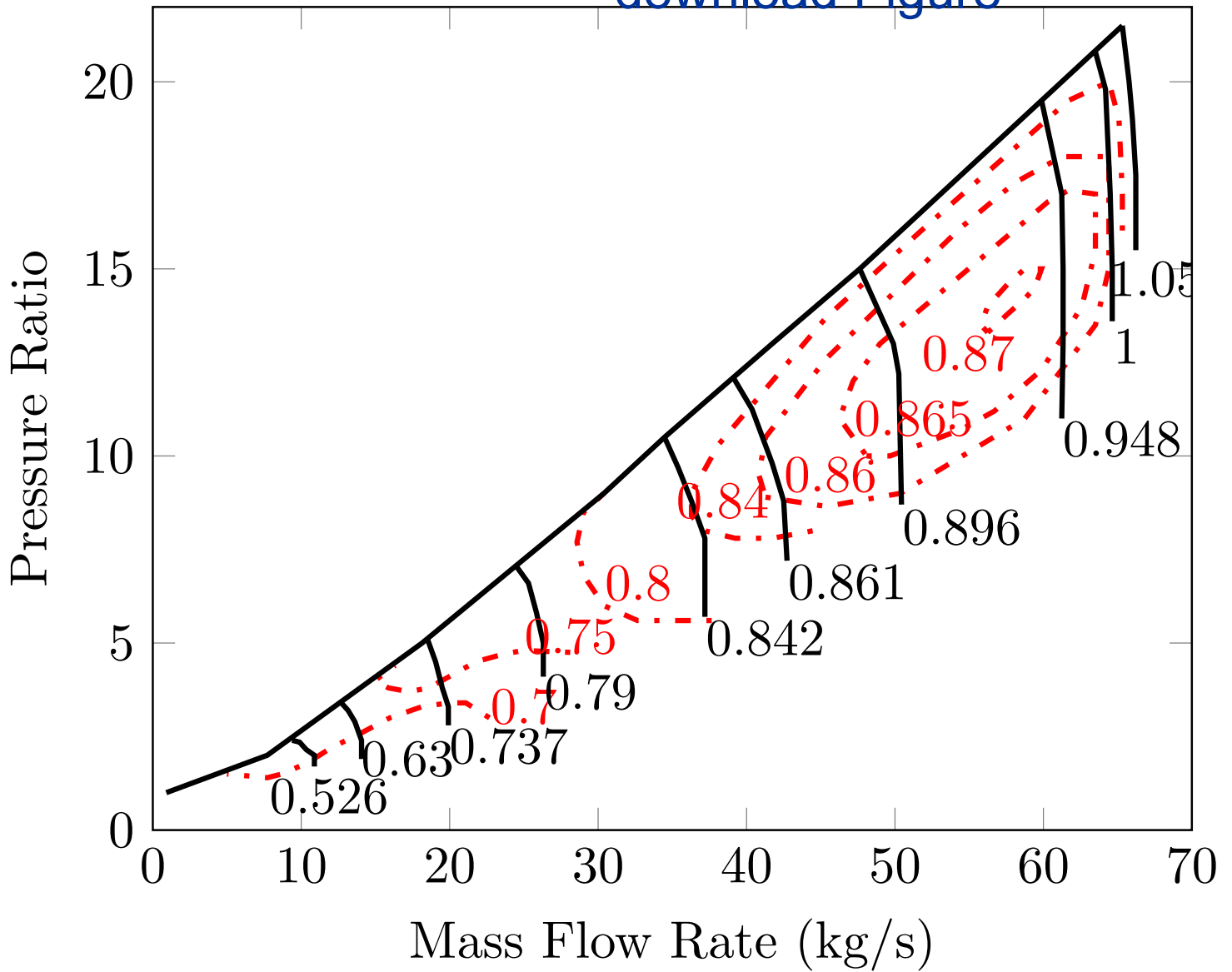

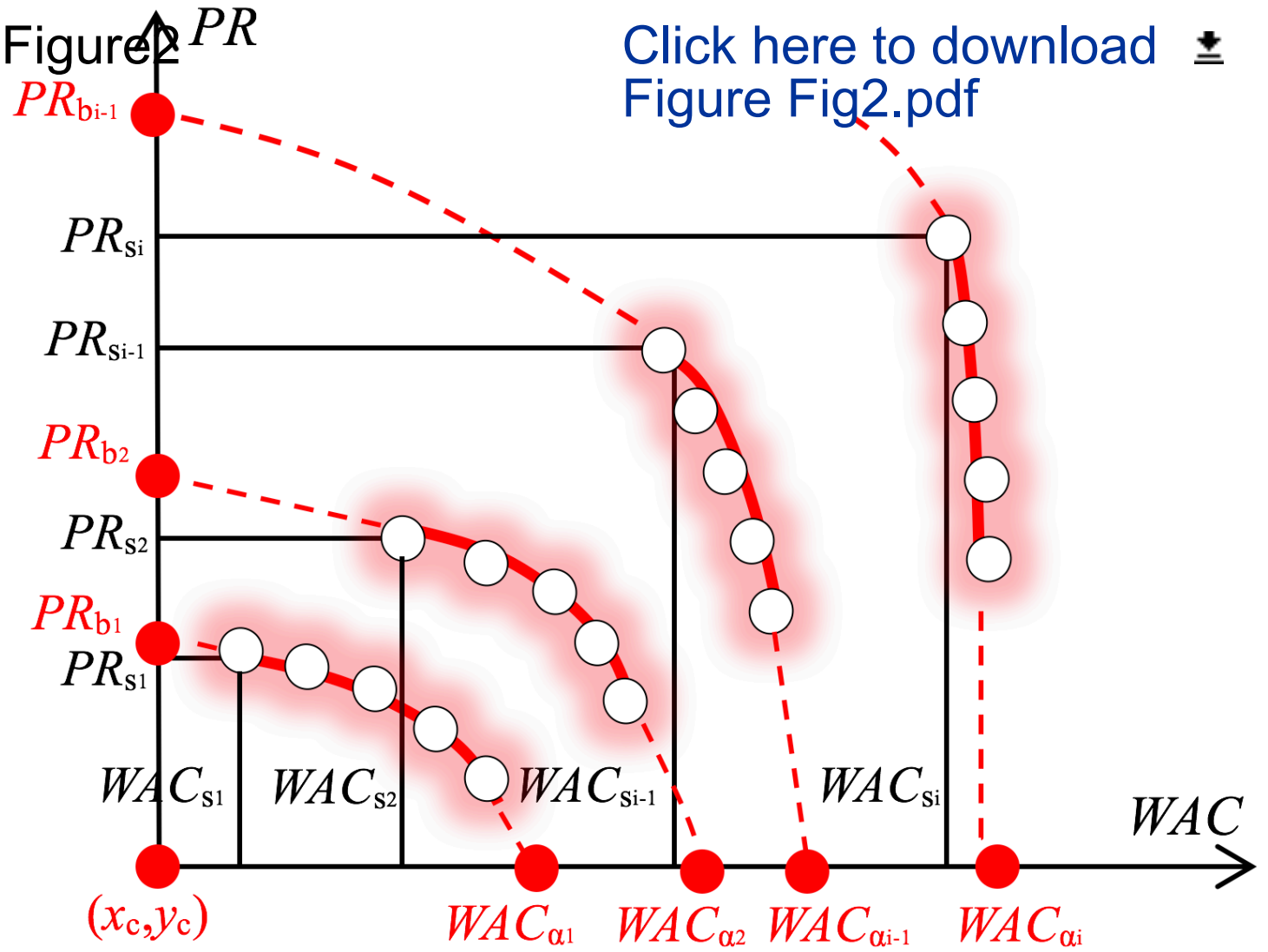

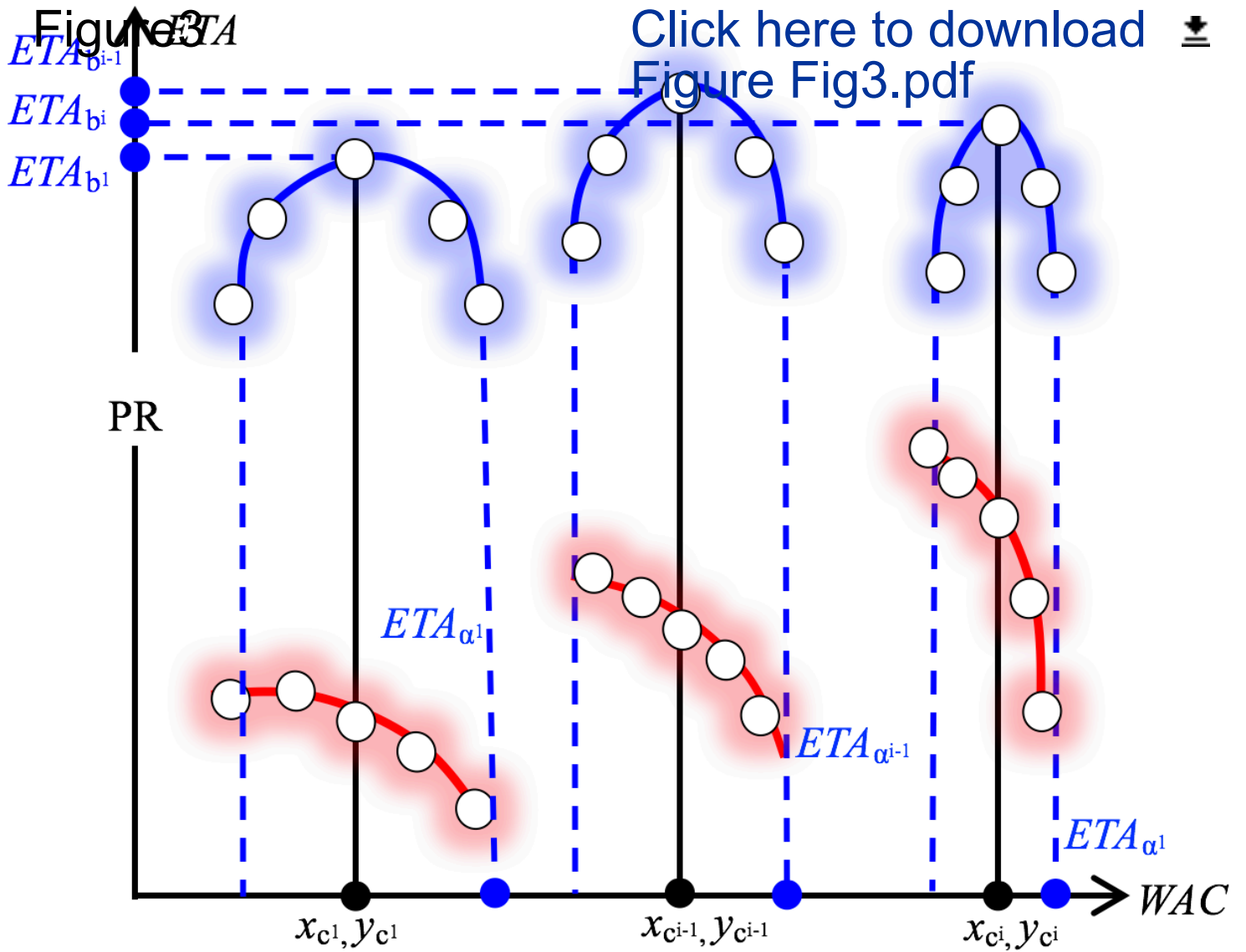

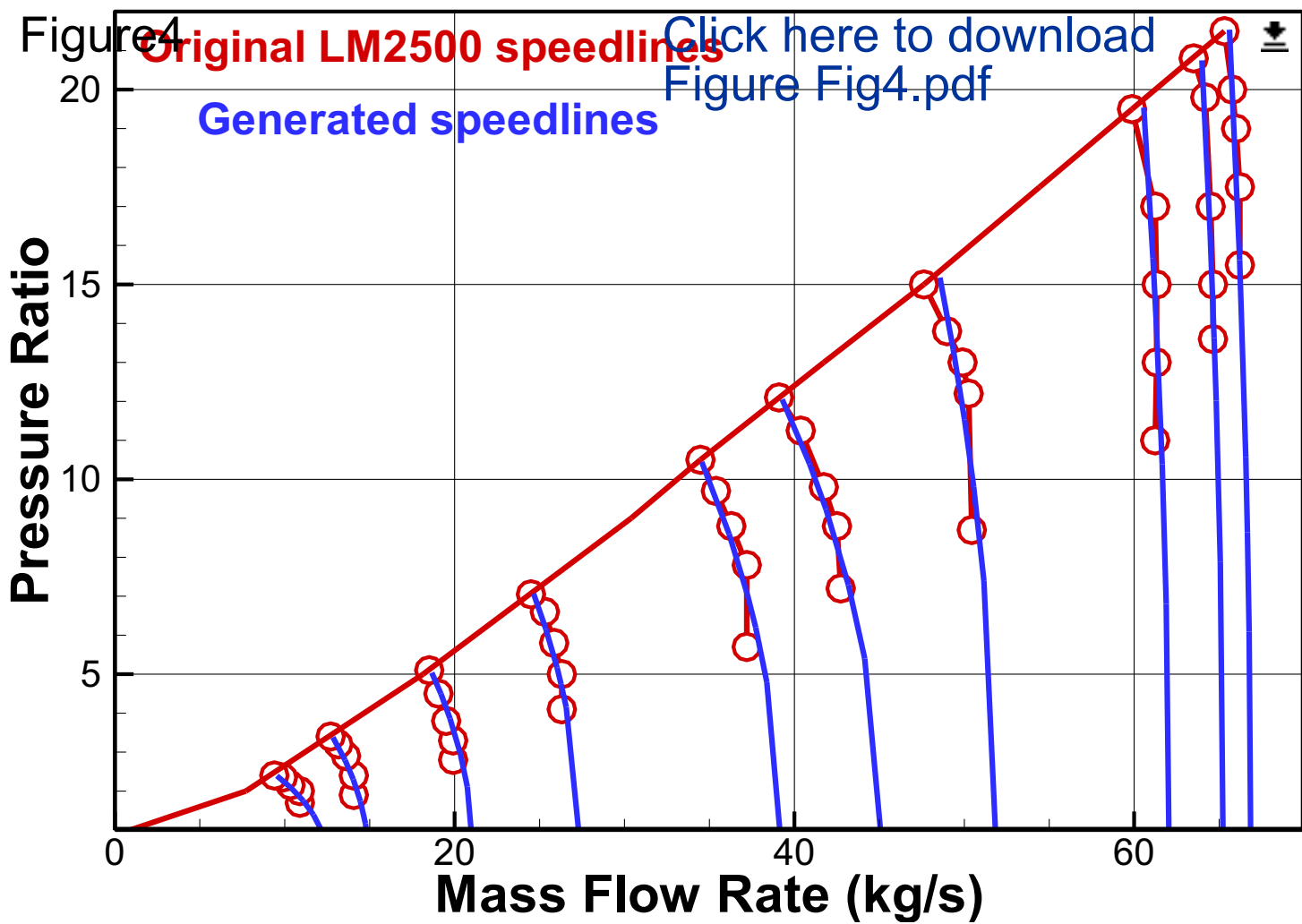
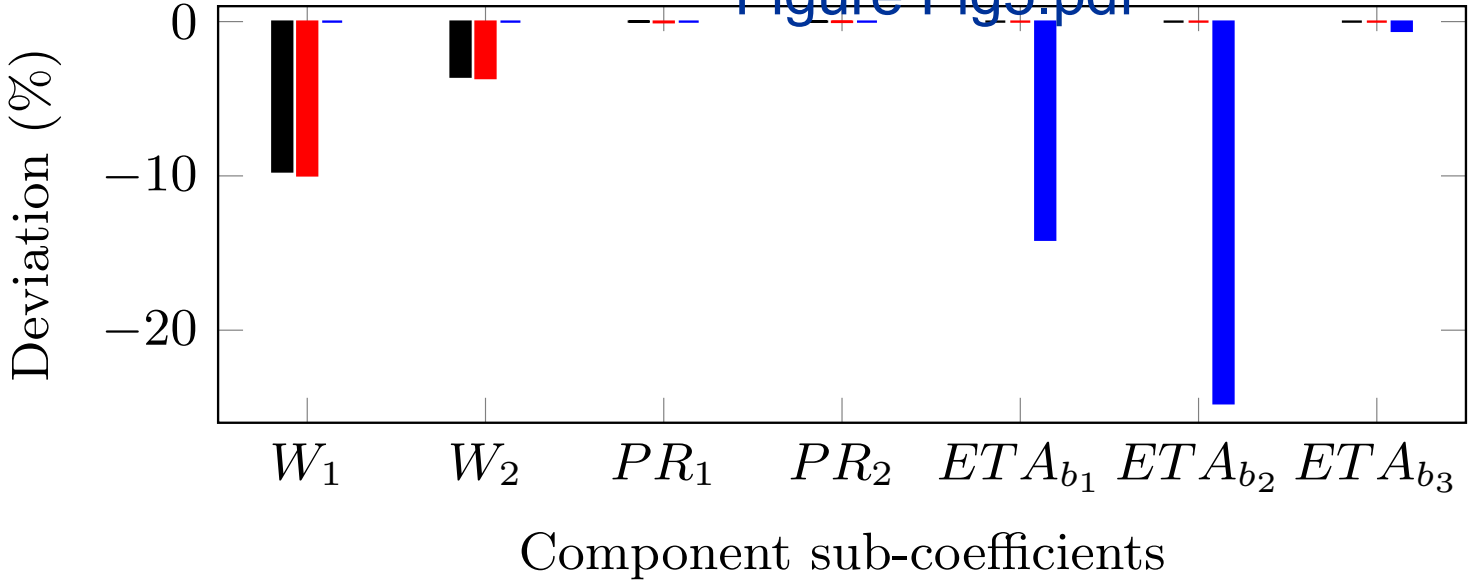

Figure5

PR **WAG** **ETA**



[Click here to download Figure Fig5.pdf](#)



Figure6

[Click here to download Figure Fig6.pdf](#)

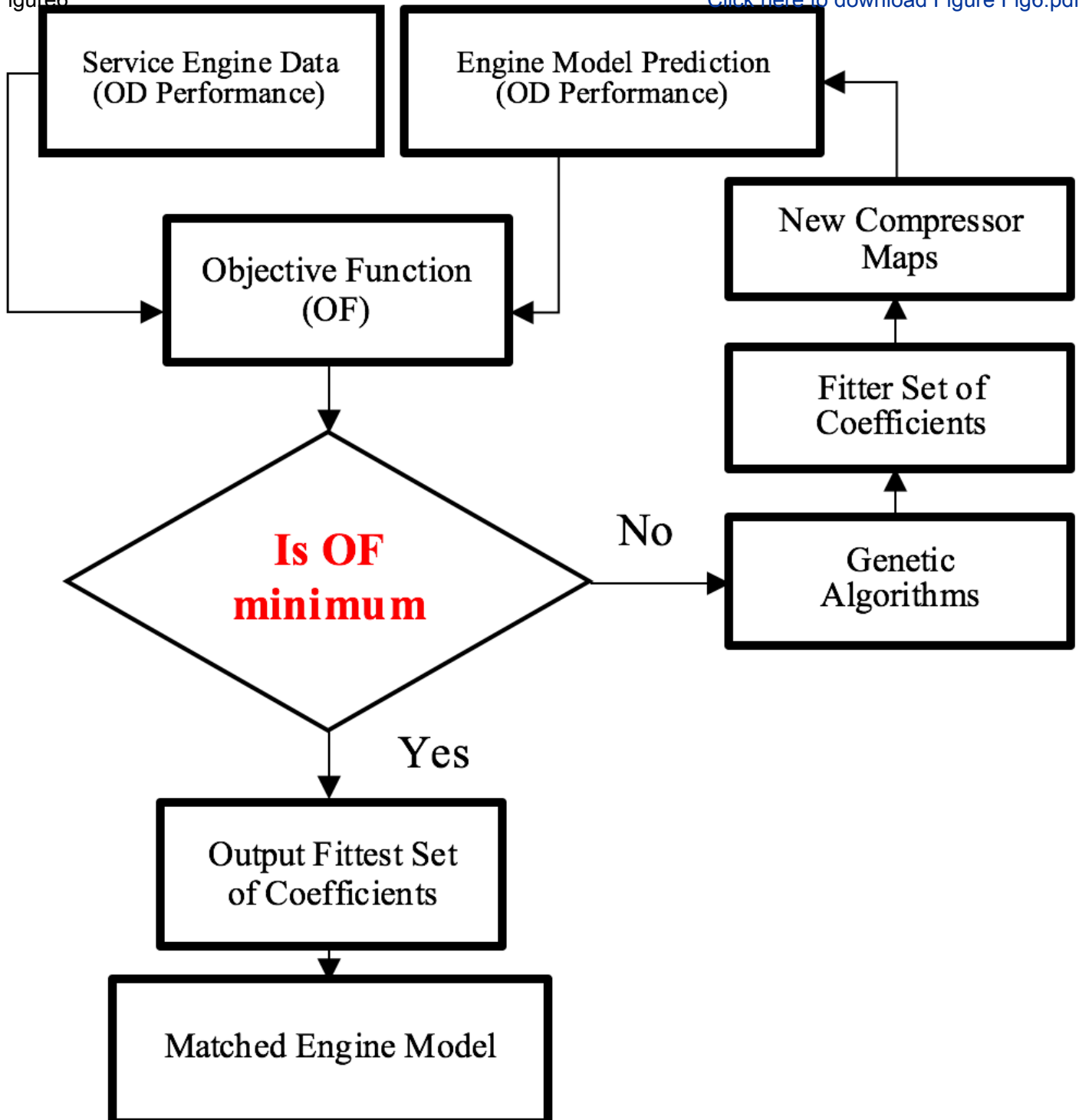

Figure7

[Click here to download Figure Fig7.pdf](#)

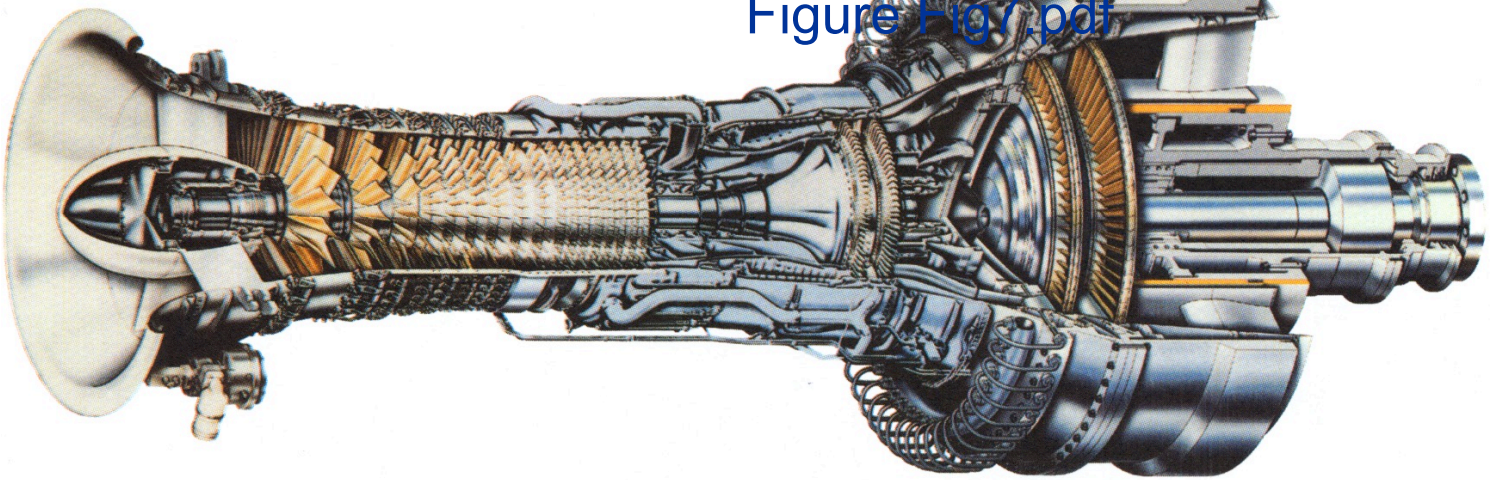

Figure8

[Click here to download Figure Fig8.pdf](#)

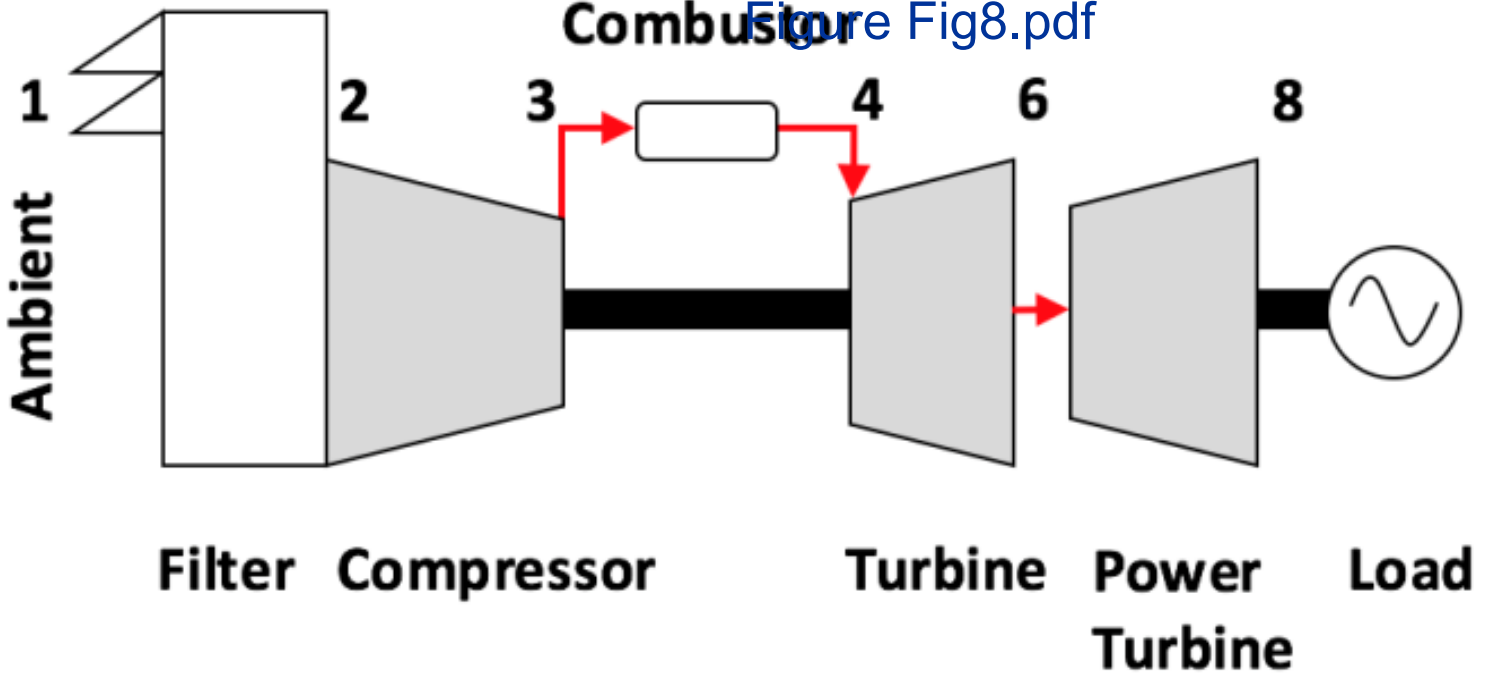
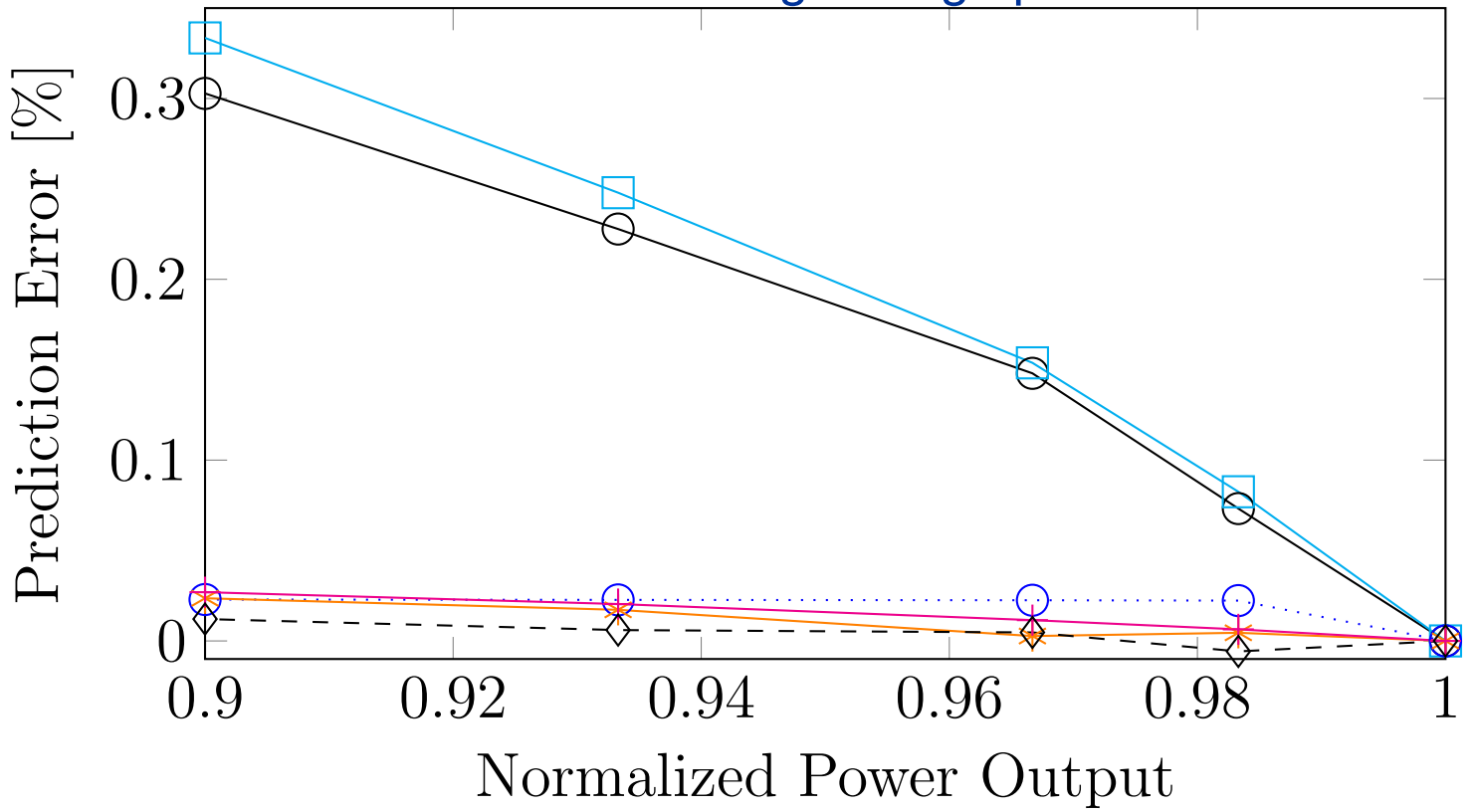

Figure9



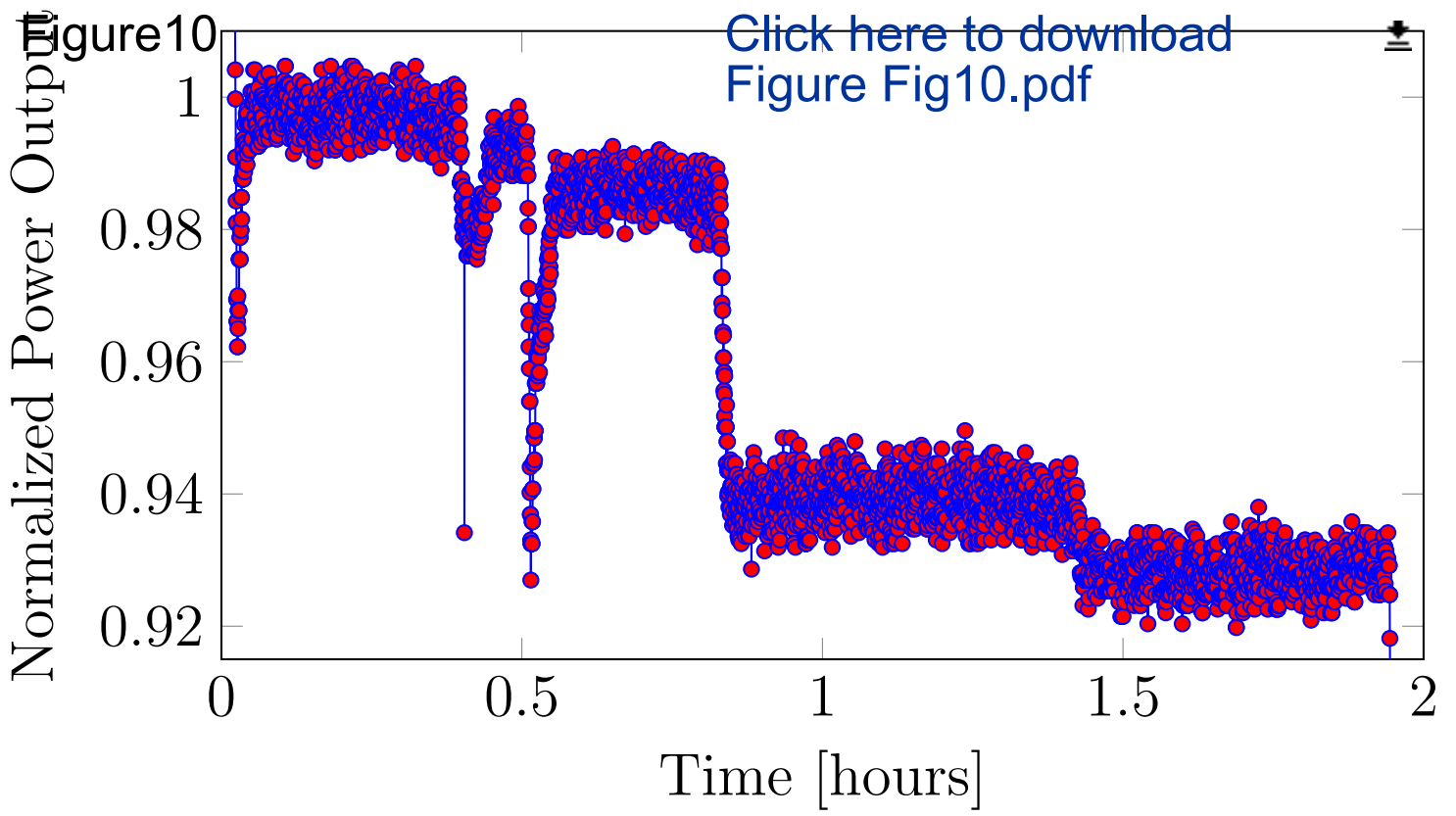

Figure11

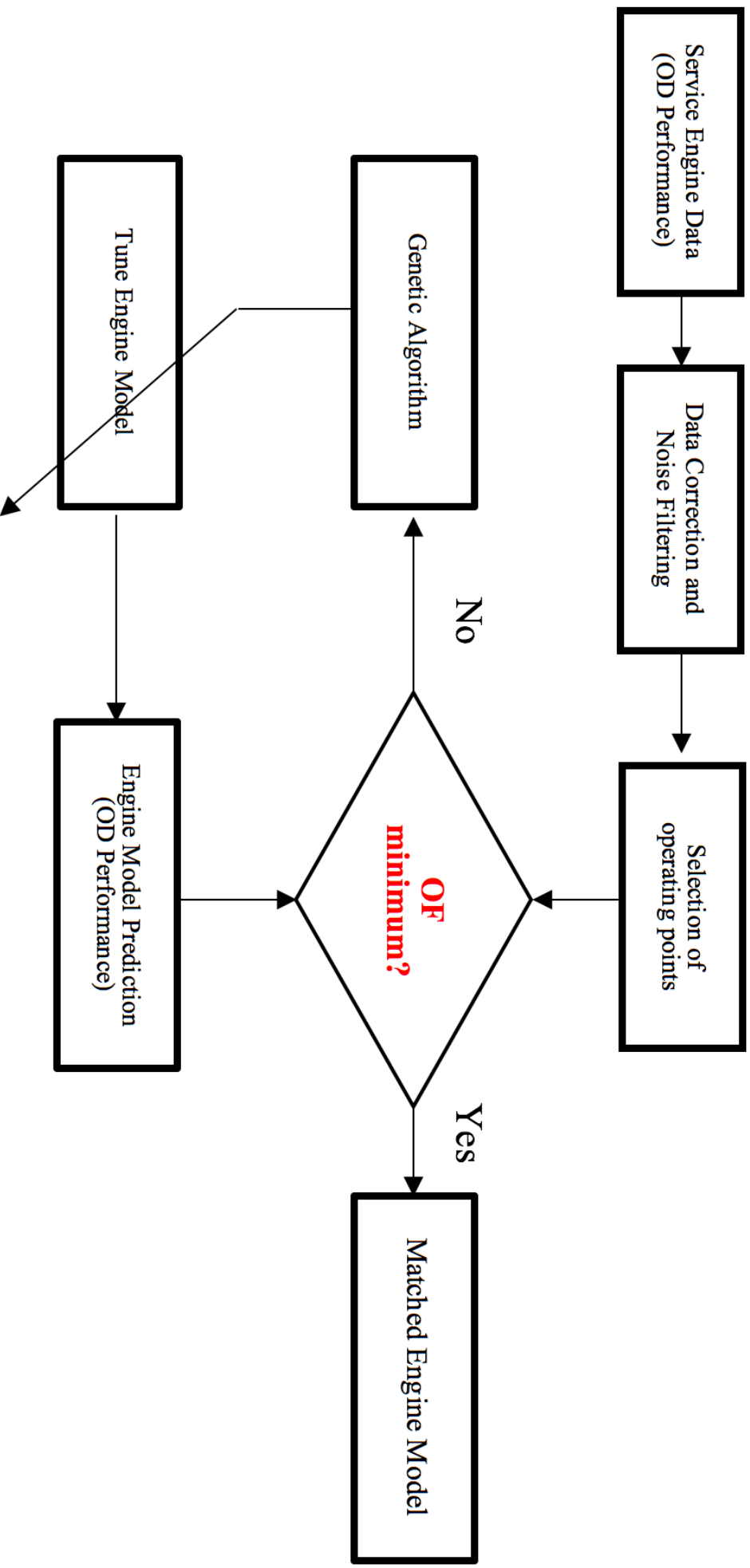

Figure 12 - Test Data - [Click here to download](#) [New method](#)
Figure Fig12.pdf

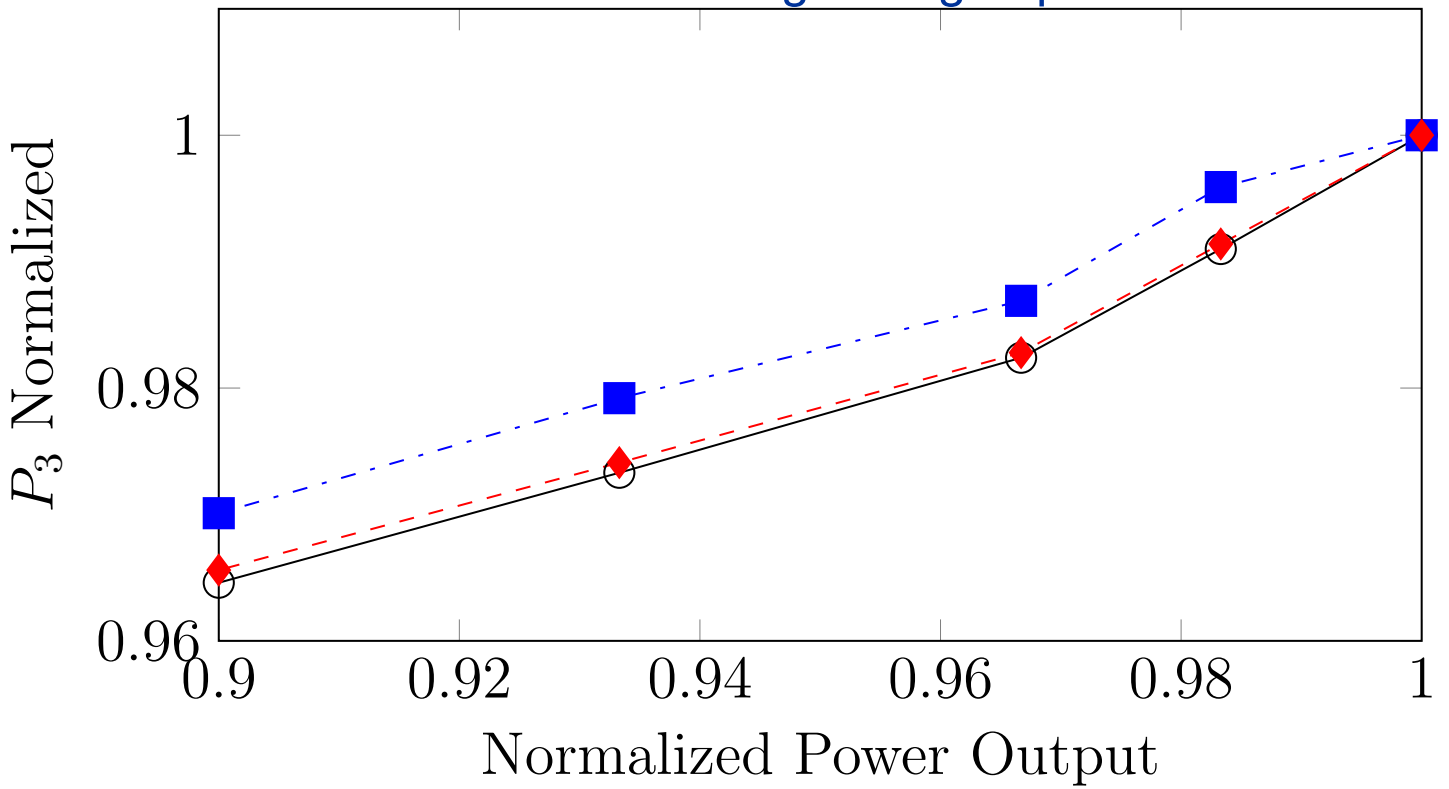
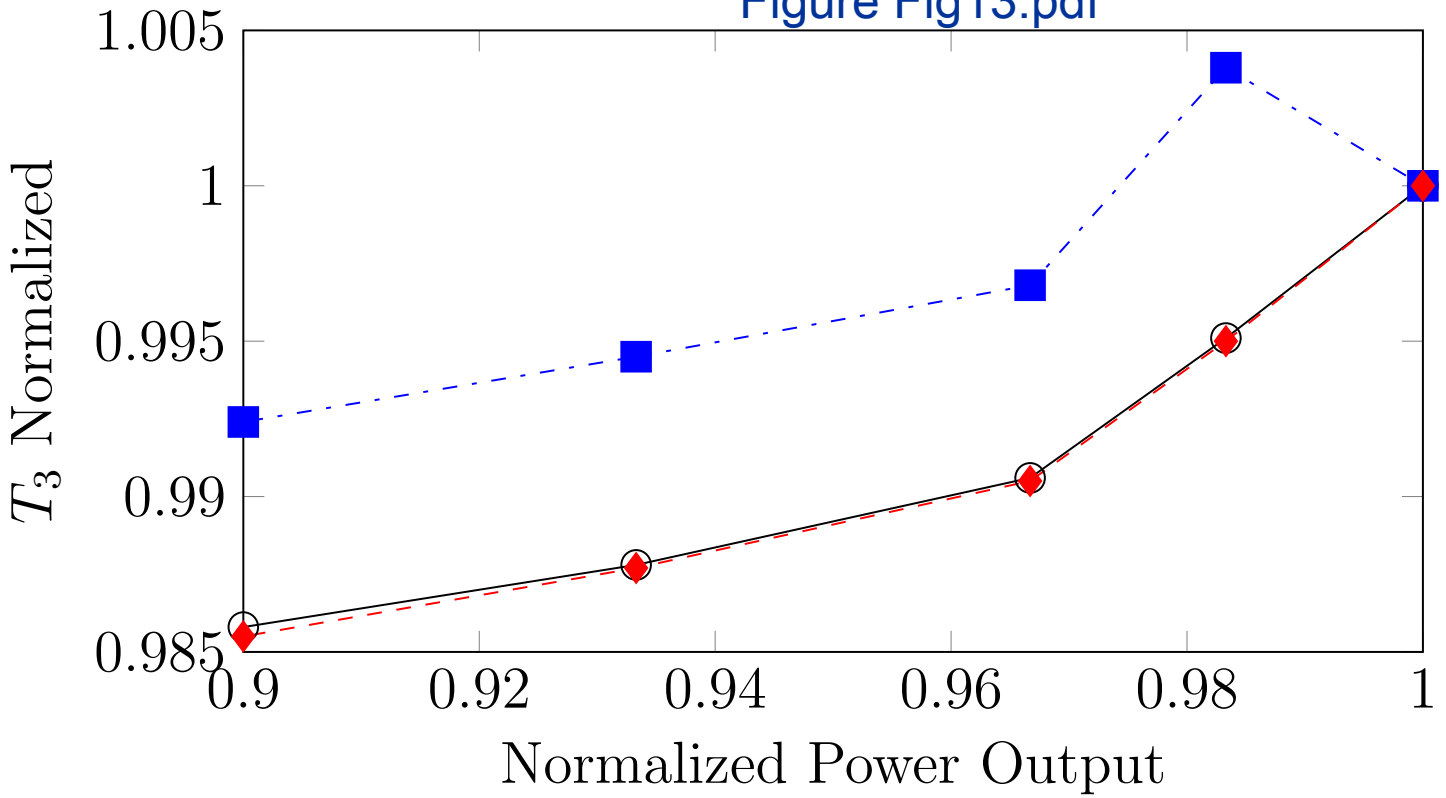
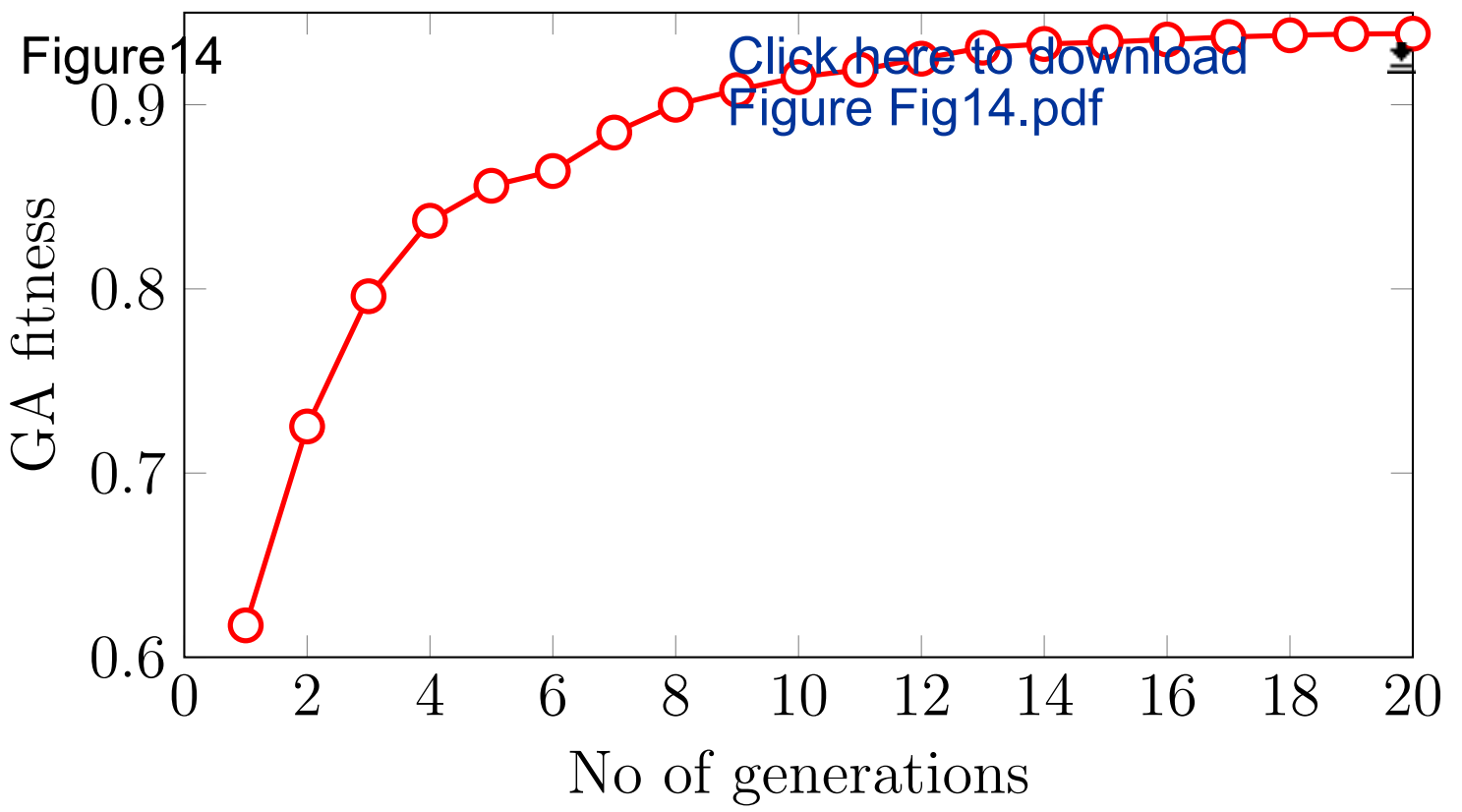

Figure 13  Click here to download Figure Fig13.pdf





Engine Model - v2_7 model



Off-Design Data Set Selection (Total Sets = 4)

Navigation buttons: <<< | 1 | >>>

Set Done

Set Delete

Set Delete All

Off-Design Performance Setting Parameters

PTURBN BD 56 (SHAFT POWER) = W

Target Measurement Parameters

Station 3 P Total (target =) A weight = 1) K
 Station 3 T Total (target =) K weight = 1) K
 Station 6 P Total (target =) weight = 1) K
 Station 6 T Total (target =) K weight = 1) K
 Station 8 T Total (target =) K weight = 1) K
 Fuel Flow Rate (target =) weight = 1) (kg/s);

To-be-adapted Component Setting

COMPRES: 1
 TURBIN: 1 2
 BURNER: 1

Scaling Factor Coefficient

	Coefficient (b)	
W1	1	TO 6
W2	2.4	TO 2.8
PR1	14	TO 21
PR2	3.8	TO 3.9
ETAb1	-0.95	TO -1.2
ETAb2	1.9	TO 6
ETAb3	-0.01	TO -0.05
	Default Setting	

Buttons: Add, Delete, Delete All, Edit

Parameter Selection

Component INTAKE 1

Data Type BD

Station Vector Setting

1
 Fuel-Air Ratio

Brick Data Setting

Altitude 1

Compressor 1 PCN

Fuel Flow Rate (kg/s)

Net Thrust (kN)

SFC

Shaft Power (W)

Thermal Efficiency (%)

GA Parameters:

Mutation: Max No. of Gens: Probability of Crossover: Convergence Criterion (Fitness):

Population Size: Probability of Mutation:

To-be-adapted Comps

COMPRES: 1 2 3 4 5

TURBIN:

BURNER:

W1:

W2:

PR1:

PR2:

ETAb1:

ETAb2:

ETAb3:

GA Fitness

Fitness Avg Max

Off-Design Data Set Selection (Total Sets = 4)

Target Measurement Parameters

Target Set	Weight	Target Value	Initial Value	Initial Error (%)	Predicted	Prediction Error (%)
Station 3 P Total	1			0.442428		0.13552939
Station 3 T Total	1			0.329368		0.11071282
Station 6 P Total	1			-1.434938E-02		-9.34675E-03
Station 6 T Total	1			7.118349E-02		8.778238E-02
Station 8 T Total	1			1.523674E-02		3.428645E-04
Fuel Flow Rate(kg/s)	1			1.527634E-02		4.760928E-04

Maximum Fitness:

Minimum Objective Function:

Generations used:



Figure17

Compressor SpeedLine Map

[Click here to download Figure Fig17.pdf](#)

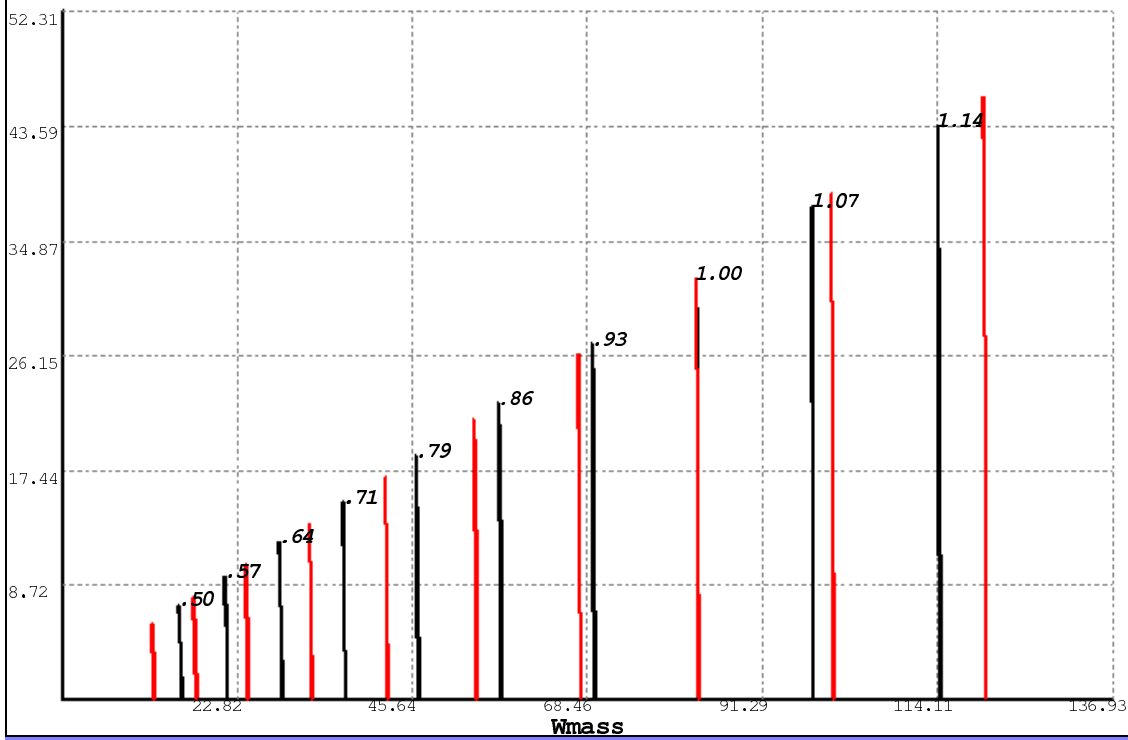

GA Optimisation Coefficients

W2	1.930264
W2	2.785442
PR1	14.10545
PR2	3.833169
ETAb1	-0.9820625
ETAb2	1.900989
ETAb3	-3.147176E-02

Scaling Factors after adaptation

PRSF	1.2933
ETASF	0.93177
WASF	0.8049

GET Adapted Map

Figure18

Isentropic Efficiency Map

[Click here to download Figure Fig18.pdf](#)

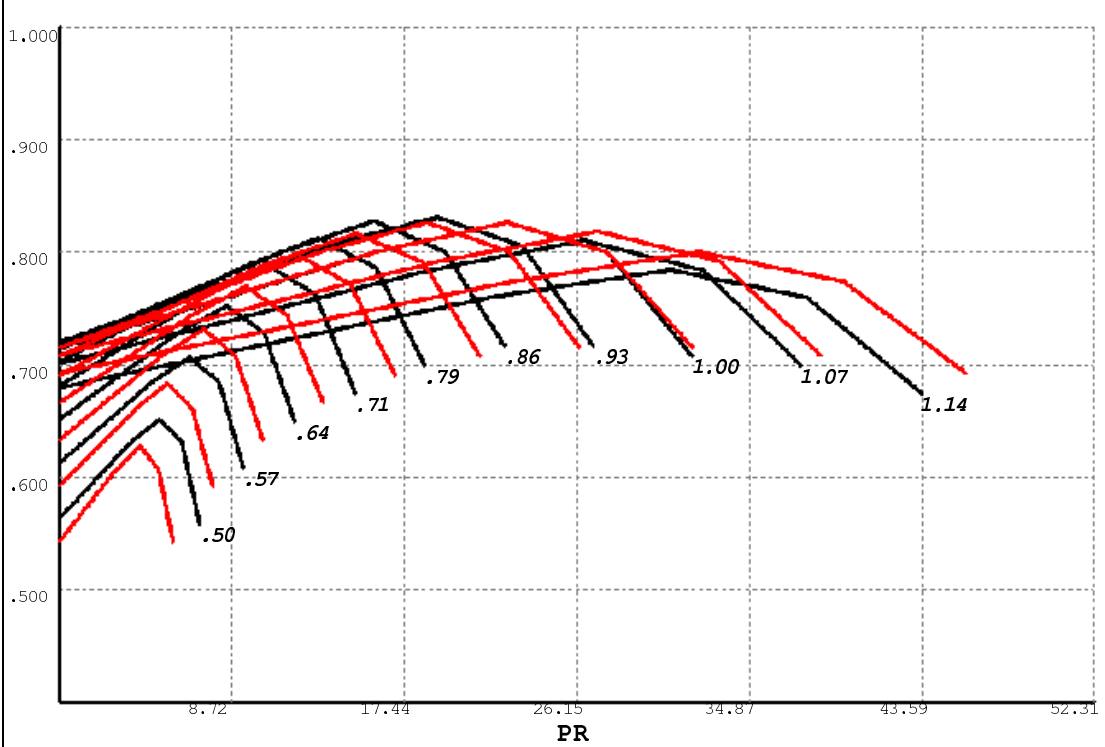

GA Optimisation Coefficients

W2	1.930264
PR1	2.785442
PR2	14.10545
ETAb1	3.833169
ETAb2	-0.9820625
ETAb3	1.900989
	-3.147176E-02

Scaling Factors after adaptation

PRSF	1.2933
ETASF	0.93177
WASF	0.8049

GET Adapted Map

Table 1: Compressor map sub-coefficients

Symbol	Description	Equation
W_1	Mass Flow exponential function	(4)
W_2	Mass Flow exponential function	(4)
PR_1	Pressure Ratio exponential function	(5)
PR_2	Pressure Ratio exponential function	(5)
ETA_{b1}	Efficiency quadratic function	(8)
ETA_{b2}	Efficiency quadratic function	(8)
ETA_{b3}	Efficiency quadratic function	(8)

Table 2: LM2500+ ISA performance specification [28]

Symbol	Parameter	Value	Units
UW	Power Output	30.2	MW
PR	Pressure Ratio	23.1	
η_{th}	Thermal Efficiency	38	%
\dot{W}_g	Exh. Flow rate	85.9	kg/s

Table 3: Engine model input parameters

Symbol	Parameter	Units
P_2	Compressor Entry Pressure	atm
T_2	Compressor Entry Temperature	K
UW	Power Output	MW

Table 4: Engine measurable performance parameters

Symbol	Parameter	Units
P_3	Compressor Discharge Pressure	atm
T_3	Compressor Discharge Temperature	K
P_6	High Pressure Turbine Discharge Pressure	atm
T_6	High Pressure Turbine Discharge Temperature	K
T_8	Power Turbine Discharge Temperature	K
ff	Fuel Flow rate	kg/s

Table 5: Adaptation test case parameters

Case No	Power (MW)	Target data	Op. points	Method
1	30-27	Deck data	4	New
2	30-27	Test data	4	Earlier & New

Table 6: Upper and lower bounds for sub-coefficients

Coefficient	Lower	Upper
W_1	1	6
W_2	2.4	2.8
PR_1	14	21
PR_2	3.8	3.9
ETA_{B_1}	-0.95	-1.2
ETA_{B_2}	1.9	6
ETA_{B_3}	-0.01	-0.05

Table 7: GA parameters

GA parameter	Value
Generations	20
Population	50
Crossover probability (%)	35
Mutation probability (%)	30

Table 8: Simulation parameters of test cases

GA parameters	Case 1 New	Case 2 Reference	Case 2 New
Generations	5	20	20
Population	50	50	50
GA Fitness	0.91	0.67	0.94
Minimum OF	0.12	0.51	0.10
Computation time per generation (s)	48	15	21

Figure Captions

- Figure 1: Compressor Map of GE LM2500 as reproduced from [25].
- Figure 2: Schematic representation of the speed lines using elliptic curves.
- Figure 3: Schematic representation of the efficiency map generation by elliptic function.
- Figure 4: Original speed lines of LM2500 compressor map vs. generated speed lines.
- Figure 5: The deviation of component map parameters PR , WAC and ETA corresponding to a -10% drop of each sub-coefficient.
- Figure 6: The flow chart of the proposed adaptation method.
- Figure 7: LM2500+ gas turbine, courtesy of GE ©
- Figure 8: Engine model layout configuration.
- Figure 9: Prediction error for the selected parameters at different power output.
- Fig. 10: Data samples representing the MU's LM2500+ off-design performance for test case 2.
- Fig. 11: Schematic representation of the proposed adaptation process for test case 2.
- Figure 12: Prediction of P_3 from new and earlier adaptation.
- Figure 13: Prediction of T_3 from new and earlier adaptation.
- Figure 14: Converge plot of the GA fitness for the test case 2 of the proposed method.
- Figure 15: Adaptation setting window of PYTHIA.
- Figure 16: Adaptation results window of PYTHIA.
- Figure 17: Compressor map in PR - WAC plane. The black and red lines correspond to the generated maps before and after off-design adaptation.
- Figure 18: Compressor performance map in ETA - PR plane. The black and red lines correspond to the generated maps before and after off-design adaptation.

Table Captions

Table 1: Compressor map sub-coefficients

Table 2: LM2500+ ISA performance specification [28]

Table 3: Engine model input parameters

Table 4: Engine measurable performance parameters

Table 5: Adaptation test case parameters

Table 6: Upper and lower bounds for sub-coefficients

Table 7: GA parameters

Table 8: Simulation parameters of test cases