

## **Shuttlecock**

HART, John <<http://orcid.org/0000-0002-6142-4515>> and HAMILTON, Nick

Available from Sheffield Hallam University Research Archive (SHURA) at:

<http://shura.shu.ac.uk/33217/>

---

This document is the author deposited version. You are advised to consult the publisher's version if you wish to cite from it.

### **Published version**

Sheffield Hallam University; Badminton Association of England Limited (2017). Shuttlecock. EP2729222B1.

---

### **Copyright and re-use policy**

See <http://shura.shu.ac.uk/information.html>



(11) **EP 2 729 222 B1**

(12) **EUROPEAN PATENT SPECIFICATION**

(45) Date of publication and mention of the grant of the patent:  
**06.12.2017 Bulletin 2017/49**

(51) Int Cl.:  
**A63B 67/187** <sup>(2016.01)</sup> **A63B 67/193** <sup>(2016.01)</sup>  
**A63B 102/04** <sup>(2015.01)</sup> **A63B 67/18** <sup>(2016.01)</sup>

(21) Application number: **12735609.5**

(86) International application number:  
**PCT/GB2012/051583**

(22) Date of filing: **06.07.2012**

(87) International publication number:  
**WO 2013/005044 (10.01.2013 Gazette 2013/02)**

(54) **SHUTTLECOCK**

FEDERBALL

VOLANT DE BADMINTON

(84) Designated Contracting States:  
**AL AT BE BG CH CY CZ DE DK EE ES FI FR GB GR HR HU IE IS IT LI LT LU LV MC MK MT NL NO PL PT RO RS SE SI SK SM TR**

(30) Priority: **06.07.2011 GB 201111544**

(43) Date of publication of application:  
**14.05.2014 Bulletin 2014/20**

(73) Proprietors:  
• **Sheffield Hallam University**  
**South Yorkshire S1 1WB (GB)**  
• **Badminton Association Of England Limited**  
**Milton Keynes, Buckinghamshire MK8 9LA (GB)**

(72) Inventors:  
• **HART, John Howard**  
**Sheffield**  
**South Yorkshire S1 1WB (GB)**

• **WOOD, Steven George**  
**Milton Keynes**  
**Buckinghamshire MK8 9LA (GB)**  
• **HAMILTON, Nick**  
**Sheffield**  
**South Yorkshire S1 1WB (GB)**

(74) Representative: **Neilson, Martin Mark**  
**Urquhart-Dykes & Lord LLP**  
**Arena Point**  
**Merrion Way**  
**Leeds LS2 8PA (GB)**

(56) References cited:  
**CN-U- 201 768 335 GB-A- 1 543 635**  
**US-A- 3 507 494**

**EP 2 729 222 B1**

Note: Within nine months of the publication of the mention of the grant of the European patent in the European Patent Bulletin, any person may give notice to the European Patent Office of opposition to that patent, in accordance with the Implementing Regulations. Notice of opposition shall not be deemed to have been filed until the opposition fee has been paid. (Art. 99(1) European Patent Convention).

## Description

**[0001]** The present invention relates to a shuttlecock and in particular, although not exclusively, to an outdoor shuttlecock configured to exhibit improved resistance during flight to environmental influences including in particular, wind forces.

**[0002]** Badminton shuttlecocks exist in a variety of different forms which fall generally into two categories: natural and synthetic. Shuttlecocks manufactured from natural materials are generally preferred by most experienced players and are used for all high level indoor competitions. These shuttlecocks typically have a cork head wrapped in goat skin with the 'shuttle' region formed from goose feathers.

**[0003]** Shuttlecocks, including both natural and synthetic, are very sensitive during flight to air resistance which in turn encompasses altitude, humidity, temperature and air current factors. When used outdoors, the latter of these environmental conditions has a profound influence on the trajectory performance and flight of the shuttlecock with regard to its direction of travel and speed. Sensitivity of shuttlecocks to environmental conditions is exemplified by the large number of different types of natural competition shuttlecocks that are used having different weightings to account for differences in altitude, humidity and temperature at different geographical locations. However, these shuttlecocks are designed exclusively for indoor use and their intended flight characteristics are disrupted significantly by wind when used outdoors.

**[0004]** Generally, traditional style shuttlecocks are made 'suitable' for outdoor use by inclusion of additional weight in the head. This additional weight is commonly only in the region of one to two grams. Other attempts to modify indoor shuttles for outdoor use include shorter skirts, smaller heads and a range of different materials for both the skirt and head. These outdoor shuttlecocks are generally designed for use with conventional badminton rackets which, to a large extent, restricts the additional weighting that can be applied to reduce the influence of wind during flight. A vast range of outdoor shuttlecocks have emerged that are entirely unsuitable for use with conventional badminton rackets being both too big and heavy.

**[0005]** With the objectives for use outdoors and with conventional badminton rackets, a number of different types of largely synthetic shuttlecocks have emerged and examples are disclosed in CA 388507, US 2218593, US 2302845, US 2247486, US 3752479, WO 8400306, FR 2594039, US 4519613, FR 2615745, DE 4005918, DE 19646508, US 5860879, US 6315687, US 6709353, CN 201195035, CN 2863200, FR 2890870, DE 102005039121, CN 201105139, CN 201200778, CN201768335, GB1543635, CN201815075, GB926049, US3359002, DE202010006986, JP54039176.

**[0006]** However, there exists a need for a shuttlecock

optimised specifically for outdoor use exhibiting improved resistance to environmental influences including in particular, wind forces. Document CN201768335U discloses a shuttlecock with a head, an elongate shaft, an annual skirt being separated from the head by approximately the length of the shaft, and radial spokes each extending from the elongate stem to the skirt.

**[0007]** The present invention refers to a shuttlecock as defined in claim 1 or a shuttlecock kit of parts as defined in claim 13.

Accordingly, the inventors provide a shuttlecock comprising physical characteristics that have been found through experimental investigation to reduce the affect of wind on the trajectory or flight of the shuttlecock when used outdoors. The present shuttlecock, in one embodiment may be considered to comprise three fundamental components, i) a head that is designed to be struck by a racket, ii) a skirt that largely controls the flight characteristics of the shuttlecock with the head and skirt being physically separated by iii) at least one elongate shaft. Accordingly, the skirt does not extend continually from the head to provide a void or gap between the head and the skirt with the shaft bridging this gap or void. According to a first aspect of the present invention there is provided a shuttlecock comprising: a head having a domed portion and a base underlying the domed portion; a shaft extending from the base of the head; an annular skirt having a trailing edge positioned furthest from the head and a leading edge positioned closest to the head relative to a longitudinal axis of the shuttlecock; radial spokes extending from a region towards one end of the shaft furthest from the head and attached to the skirt; wherein the leading edge of the skirt is separated from the head relative to the longitudinal axis of the shuttlecock by a distance along the length of the shaft; the shuttlecock characterised in that: the skirt is formed as a unitary body; and the radial spokes each comprise a curvature in a radial direction between the shaft and skirt.

**[0008]** Preferably, each spoke comprises a curvature extending in the axial direction between the shaft and skirt. More preferably, the curvature of each spoke in the radial direction comprises a concave and a convex region along its length. Optionally, each spoke is twisted along its length, the twist being provided in the 'depth' of the spoke extending in the longitudinal direction of the shuttlecock. The curvature is advantageous in that each spoke is capable of compressing via its curvature to absorb an impact force when hit with a badminton racquet. Also, the twist in each spoke provides or facilitates riffling during trajectory. By adjusting the angle of twist of each spoke relative to the longitudinal direction of the shuttlecock, the degree of riffling can be tailored.

**[0009]** Preferably, the shuttlecock comprises three spokes extending between the shaft and the skirt. Preferably, each spoke terminates at a common central boss having a mounting portion wherein the shaft is detachably mounted at the central boss via the mounting portion. Optionally, the spokes may be formed integrally with the

shaft being of the same material. Optionally, the spokes, the shaft and the skirt are formed integrally.

**[0010]** Optionally, each spoke comprises a blade-like configuration comprising a width extending perpendicular to the longitudinal axis and a depth extending in the longitudinal axis wherein the depth is greater than the width. Optionally, the width of each spoke at the region towards the shaft is greater than the width towards the skirt. Optionally, a depth of each spoke in the longitudinal axis direction increases at a radially outermost region in contact with the skirt.

**[0011]** Preferably, the head is detachably mounted at the shaft and is non-integrally formed. Alternatively, the head may be integrally formed with the shaft. Preferably, the shaft comprises a mounting tongue and the head comprises a mouth at the base to receive the tongue and mount the head at the shaft. Alternatively, the shaft and head may comprise any form of releasably attachable locking arrangement including in particular a bayonet type coupling, screw threads, snap-click or push-fit connectors such that the shaft and the head may be attached and readily detached by applying either a pulling, pushing or twisting motion to the head and/or the shaft.

**[0012]** Optionally, the shuttlecock further comprises a head mount section detachably coupled to the shaft and configured to mount the head via the base underlying the domed portion. Preferably, the head mount section comprises a through-bore to receive a portion of an end region of the shaft to connect the head mount section and the shaft. Optionally, the head mount section comprises a mounting tongue and the head comprises a mouth at the base to receive the tongue and mount the head at the shaft.

**[0013]** Preferably, the skirt comprises webbing extending between the leading and trailing edges. The term 'webbing' includes all manner of mesh and lattice type structures formed from relatively thin strands of material so as to form an open pore type structure having apertures through which air may pass. The skirt may comprise regions of webbing having different material thicknesses and different webbing patterns wherein the density of the apertures, including the size of the gaps between the web strands is variable. Also, the thickness of the web strands may be different at different regions of the skirt.

**[0014]** Optionally, an outward facing surface of the skirt is convex between the leading and trailing edges. Alternatively, the outer facing surface of the skirt may be concave or may be linear so as to define a hollow frustoconical shape.

**[0015]** Optionally, the skirt comprises a continuous annular configuration extending circumferentially around the longitudinal axis. Optionally, the skirt comprises radially extending perforations that increase in size in the axial direction from the leading edge to the trailing edge. Reference within this specification to an 'annular skirt', include both circular and polygonal skirt geometries extending around the central longitudinal axis of the shuttlecock.

**[0016]** Optionally, the skirt comprises radially extending perforations that increase in size in the axial direction from the leading edge to the trailing edge.

**[0017]** The separation of the head and the skirt in the longitudinal direction of the shuttlecock has been found to reduce the deflection affect of the wind. That is, and referring to conventional shuttlecocks where the skirt extends directly from the head, the present shuttlecock is devoid of the skirt at the region immediately behind the head with this void space being occupied only by the relatively thin shaft. Any cross-wind incident at the shuttlecock during flight is therefore capable of passing through this open void region. Accordingly, the inventors have optimised the distance over which the skirt extends in the longitudinal direction of the shuttlecock so as to provide the required characteristics of turn over speed and 'feel' during a strike. The present invention by virtue of the design of the spokes and skirt also provides the desired gyroscopic precession during the latter half of the shuttlecock's trajectory mirroring that of natural indoor competition shuttlecocks.

**[0018]** Optionally, each spoke comprises a thickness in a range of 0.8 mm to 0.4 mm. Optionally, the skirt comprises a thickness in a range 0.4 mm to 0.2mm. Optionally, the skirt comprises a tapered thickness that decreases from the leading edge to the trailing edge. Preferably, the shaft, spokes and skirt comprise a thermoplastic and are formed by an injection moulding process. Preferably, the material comprises any one of the following: a polyamide (preferably Nylon); polypropylene; polyethylene; polystyrene; polyvinyl chloride; polytetrafluoroethylene PTFE); polyester; polylactic acid; polyurethane; an acrylic. Alternatively, the material of the shaft, skirt and/or spokes may comprise a rubberised material, a rubberised thermoplastic material and optionally a copolymer being preferably a polyester-polyether copolymer

**[0019]** Optionally, the head may comprise a natural material such as cork optionally covered by goat skin. Alternatively, the head may comprise a synthetic and optionally a thermoplastic, a rubber, a foam material and in particular a polyurethane foam or a polyethylene foam.

**[0020]** According to a second aspect of the present invention there is provided a shuttlecock kit of parts comprising: at least one head having a domed portion and a base underlying the domed portion; at least one shaft extendable from the base of the head; a plurality of annular skirts, each skirt having a trailing edge positionable furthest from the head and a leading edge positionable closest to the head relative to a longitudinal axis of the shuttlecock; radial spokes extending inwardly from each skirt towards a longitudinal axis bisecting centrally each annular skirt, each spoke of each skirt comprising a curved region extending in a radial direction from the shaft to the skirt; wherein each skirt is formed as a unitary body and comprises a different respective shape and/or size and may be interchanged with the at least one head to change the shape and/or size of the shuttlecock.

**[0021]** A specific implementation of the present invention will now be described, by way of example only and with reference to the accompanying drawings in which:

Figure 1A is the perspective view of a shuttlecock according to a specific implementation of the present invention having a head, a skirt and an intermediate shaft connecting the head and skirt;

Figure 1B is a further perspective view of the shuttlecock of figure 1A;

Figure 1C is a side elevation view of the shuttlecock of figure 1B;

Figure 2A is an exploded perspective view of the shuttlecock of figure 1C;

Figure 2B is an exploded side view of the shuttlecock of figure 2A;

Figure 2C is a perspective view from below of the head of the shuttlecock of figure 2A;

Figure 3A is a plan view of the shuttlecock of figure 1C;

Figure 3B is an underside view of the shuttlecock of figure 1C;

Figure 4A is a side elevation view of a skirt having a linear outward facing surface according to a further embodiment of the present invention;

Figure 4B is a plan view of the skirt of figure 4A;

Figure 4C is a perspective view of the skirt of figure 4B;

Figure 5A is a side elevation view of a skirt having a concave outward facing surface according to a further specific implementation of the present invention;

Figure 5B is a plan view of the skirt of figure 5A;

Figure 5C is a perspective view of the skirt of figure 5B.

Figure 6 is a perspective underside view of a shuttlecock according to a further specific implementation of the present invention in which a skirt and mounting shaft are formed integrally and a head mounting portion is formed non-integrally;

Figure 7A is an exploded underside view of the shuttlecock of figure 6;

Figure 7B is an exploded perspective top view of the

shuttlecock of figure 6.

**[0022]** Referring to figures 1A to 3B, the shuttlecock comprises three fundamental components a head 100, a skirt 102 and an intermediate shaft 101 extending between head 100 and skirt 102. Head 100, shaft 101 and skirt 102 are co-aligned along a longitudinal axis 121 bisecting centrally through the shuttlecock.

**[0023]** Head 100 has a domed upper region 103 that provides a strike zone of the shuttlecock being the region intended for contact by a badminton racket. A cylindrical section 104 extends immediately below the dome 103 and terminates at a base portion 105. The shaft 101 has a straight elongate section 106 that tapers or flares outwardly at an upper region 107. The flared region 107 terminates at an annular disc 108 extending radially from elongate shaft 106. A hollow cylindrical tongue 200 extends from an upper facing surface of disc 108 and comprises an annular lip 201 extending circumferentially around an upper edge of the tongue 200. An open cavity 202 extends the length of hollow tongue 200 from disc 108 to lip 201. According to further specific implementations, tongue 200 may not comprise internal cavity 202 and may be formed as a solid extension from disc 108. Additionally, the material of tongue 200 may be different to that of shaft 101 so as to change the 'weighting' characteristics of the shuttlecock at the region of head 100.

**[0024]** Head 100 comprises an internal cavity 203 extending from base 105 through cylindrical region 104 towards dome 103. The depth of cavity 203 is approximately equal to the length of tongue 200 and a diameter of cavity 203 is approximately equal to, if not slightly less than, a diameter of tongue 200. Lip 201 comprises a diameter slightly greater than the diameter of cavity 203 so as to provide a frictional fit as tongue 200 is mated within the cavity or mouth 203 of head 100 and base 105 is mated with the upper facing surface of disc 108 such that head 100 is detachably connected to shaft 101.

**[0025]** Skirt 102 is annular about longitudinal axis 121 and is separated radially from axis 121 by a distance that changes along the length of skirt 102 from a leading edge 112 to a trailing edge 113. Skirt 102 therefore extends radially outward from central axis 121 along the length of the shuttlecock in the direction from head 100 to skirt 102. The body of skirt 102 is formed by webbing being parallel aligned strips 114 extending between leading and trailing edges 112, 113 to create a plurality of apertures 115, 122 extending through the skirt 102 from an inward facing surface 301 to an outward facing surface 205. Strips 114 are formed as elongate thin regions of skirt 102 such that apertures 115, 122 are also elongate and extend a distance over the length of skirt 102 between the leading and trailing edges 112, 113 in the same direction as longitudinal axis 121. A first set of webbing 117 extends from leading edge 112 towards trailing edge 113 and terminates less than half the distance between these two edges 112, 113 to define elongate apertures 122. A second set of webbing 116 extends from trailing

edge 113 towards leading edge 112 over more than half of the length of skirt between the edges 112, 113 to define elongate apertures 115. A narrow annular collar 118 extends between the two sets of webbing 116, 117 approximately one third the distance between edges 112, 113 closest leading edge 112. Additionally, a similar annular collar 119 extends between webbing 116 and trailing edge 113 and a third annular collar 120 extends between leading edge 112 and webbing 117. Accordingly, the length of apertures 122 of the first set of webbing 117 is less than the length of apertures 115 of the second set of webbing 116. Collars 118, 119, 120 are devoid of apertures 115, 122 and increases the general stiffness of the skirt 102 and its resistance to bending, folding and twisting when struck by a racquet.

**[0026]** Skirt 102 is connected to shaft 101 via radial spokes 111 that extend from the inward facing surface 301 of skirt 102 to a central boss 109 positioned on the longitudinal axis 121. As detailed in figures 3A and 3B, each spoke 111 is curved along its length between boss 109 and skirt 102 to provide a means of absorbing an impact force imparted to the shuttlecock each time it is stuck with a badminton racquet. In particular, the curvature of each spoke 111 includes a concave region 303 and a convex region 304.

**[0027]** Each spoke 111 comprises a depth extending in the longitudinal axis direction 121, that decreases from the region of boss 109 towards skirt 102 such that a separation distance between a leading edge 207 and a trailing edge 208 of each spoke 111 decreases from boss 109 towards skirt 102. Additionally, each spoke is twisted along its length. The twist between the leading and trailing edges 112, 113 is created as a boss end 206 of each spoke 111 is attached to boss 109 along a helical path (extending over the outer surface of boss 109) whilst the opposite skirt end 300 of each spoke 111 is attached at a region 302 to skirt 102 in an alignment substantially parallel with longitudinal axis 121. Accordingly, the majority of a surface 123 of each spoke 111 extending between edges 207 and 208 is aligned at a small acute angle relative to the longitudinal axis 121. This different attachment alignment of each spoke 111 (at boss 109 and skirt 102) provides a diminishing lengthwise twist 305 along the length of each spoke 111 from boss end 206 towards skirt end 300. This twist is advantageous to provide and/or facilitate rifling of the shuttlecock during trajectory. Each region 302 is devoid of apertures 122 and is provided on the inward facing surface 301 between intermediate collar 118 and leading edge collar 120.

**[0028]** Central boss 109 is substantially hollow and comprises an open ended cavity 204 to receive a second end 110 or shaft 101. The diameter of shaft end 110 is approximately equal to the diameter of boss cavity 204 so as to provide a frictional fit and enable shaft 101 to be mated and detachably connected to skirt 102. Additional locking connections (not shown) may be provided at shaft end 110 and boss 109 to releasably lock shaft 101 to skirt 102. Suitable connections may include bayonet,

twist lock, harpoon or other push/pull type interconnections to enable shaft 101 and skirt 102 to be connected and detached via a simple pushing/pulling and/or twisting action. Similar connections may also be provided at head 101 and a first end of shaft 101 so as to releasably lock head 100 to shaft 101.

**[0029]** Figures 4A to 4C illustrate a further embodiment of skirt 102. Referring to figure 4A, the annular outward facing surface 400 of skirt 102 between edges 112, 113 is substantially linear. Additionally, the attachment region 401 of each spoke 111 between the spoke leading edge 207 and trailing edge 208 is aligned substantially parallel to the longitudinal axis 121 in contrast to the embodiment of figures 1A to 3B. Accordingly, each spoke 111 of the embodiment of figures 4A to 4C does not comprise the same twist 305 illustrated in figure 3B. However, each spoke 111 of the embodiment of figures 4A to 4C has the concave 303 and convex 304 dual curvature along its length between boss 109 and inward facing surface 301 of skirt 102.

**[0030]** Figure 5A to 5C illustrate a yet further embodiment in which the outward facing surface of skirt 102 between leading and trailing edges 112, 113 is concave 500 relative to the longitudinal axis 121. According to this further embodiment, the spokes 111 are the same as described with reference to the embodiment of figures 4A to 4C.

**[0031]** Figures 6 to 7B illustrate a further embodiment of the present invention. In contrast to the previous embodiment, the further embodiment comprises three separate parts, a flight section (or skirt 102); a head section 100 and a head mount section 705. The elongate shaft 101 that extends between head 100 and skirt 102 according to the further embodiment is formed integrally with skirt 102 and extends from boss 109.

**[0032]** In particular, shaft 100 comprises a main shaft 600 extending axially from boss 109 and a fixing shaft 700 extending coaxially with shaft 600. Main shaft 600 is tapered and comprises a decreasing diameter in a direction from skirt 102 towards head 100. Similarly, fixing shaft 700 is also tapered and comprises a decreasing diameter in a direction from skirt 102 to head 100. Additionally, main shaft 600 comprises a step-down section 701 at the interface of the fixing shaft 700 and main shaft 600 with section 701 presenting an annular seating collar at the junction between shafts 600, 700.

**[0033]** Head support 705 comprises a disk-like base 108 having a flared underside 107 and hollow cylindrical tongue 200 projecting from an opposed upper surface as described with reference to the first embodiment. However, flared section 107 terminates at an axially central mounting boss 703 intended to be facing skirt 102 when the shuttle is assembled. Boss 703 comprises a through-bore that extends centrally through head support 705 and is dimensioned so as to accommodate the end region 704 of fixing shaft 700. The diameter of bore 702 is slightly less than a diameter of shaft 700 at the region of step-down 701 such that shaft 700 may be held tightly

by frictional contact forces between bore 702 and its outer surface. Through-bore 702 comprises a tapered inner surface such that the diameter of the bore decreases from the underside flared region 701 towards the upper region of support 705. Accordingly, shaft 700 may be fully inserted within bore 702 such that section 701 sits against boss 703.

**[0034]** As with the previous embodiment, skirt 102 comprises a plurality of apertures to achieve the desired flight characteristics. According to the further embodiment, apertures 603 are arranged into twelve evenly spaced, circumferentially distributed groups 602, with each group comprising six rows of perforations 603 in the axial direction. Additionally, the perforations 603 increase in size from a first set 604 located towards leading edge 112 and a set of larger dimensioned perforations located towards trailing edge 113 when the shuttle is orientated in flight. Additionally, apertures 603, 604 are bevelled on the inner surface of annular skirt 102 to facilitate production.

**[0035]** As illustrated in figures 6 and 7B, each of the three radial spokes 111 is attached at respective skirt ends 601 to the inner surface of skirt 102. The length of attachment of each spoke end 601 is approximately equal to the axial length of skirt 102 between leading edge 112 and trailing edge 113. Accordingly, the axial length of each spoke 111 decreases from the skirt end 601 to the attachment region 401 at boss 109.

**[0036]** As illustrated in figures 6 to 7B, each spoke 111 comprises the same double twist (concave and convex curvature) along their length extending in the radial direction outwardly from shaft 600 to skirt 102. Accordingly and as detailed in the previous embodiment, this curvature is configured to enable the spokes to twist and absorb impact forces imparted to the shuttle from the racket in addition to inducing riffling spin during flight. As detailed previously, each spoke 111 is blade-like and comprises a greater depth in the direction of the longitudinal axis of the shuttlecock relative to the respective width in a perpendicular (or radial) direction.

**[0037]** The present shuttle is advantageous as the skirt 102 is a unitary body which provides structural integrity to withstand the loading forces. This is to be contrasted to a skirt formed as a collection of individual components such as natural or synthetic feather-like blades. Accordingly, this allows a minimum number of spokes 111 to achieve the required strength of connection between the circumferentially extending skirt 102 and axial shaft 600. These spokes may then be spaced apart in the circumferential direction (about shaft 101) so as to have a greater influence on the flight characteristics. To further enhance the flight characteristics and strength of the shuttle, annular skirt 102 comprises a tapered wall thickness from leading edge 112 to trailing edge 113. According to the specific implementation of figures 6 to 7B this wall thickness decreases from 0.5 mm at leading edge 112 to 0.35 mm at trailing edge 113.

**[0038]** As detailed with reference to both embodi-

ments, spokes 111 are separated from head 100 and in particular head base 105 by substantially the majority of the length of shaft 101 (comprising shafts 600 and 700). This separation facilitate the flow of air over spokes 111 and skirt 102 to achieve the desired flight characteristics provided by the skirt perforations 603, 604 and the curvature of spokes 111.

**[0039]** By forming the skirt 102 and shaft 101 non-integrally in one embodiment or the shaft 101 and head mounting portion 705 non-integrally according to a further embodiment and configuring the separate components to releasably lock together, it is possible for a user to interchange different skirt and head components as desired. According to further embodiments, different skirts 102 may be provided and interchanged having very different shapes, body thicknesses, webbing, weighting and materials. Additionally, the spokes 111 of each skirt may be the same or different and comprise different curvature with regard to the concave and convex regions 303, 304, twist 305 and thickness between leading and trailing edges 207, 208. Additionally, and according to further embodiments, each skirt 102 may comprise a different number of spokes extending radially from central boss 109 to inward facing surface 301 and/or different configurations of perforations 112, 115, 603, 604.

## Claims

### 1. A shuttlecock comprising:

a head (100) having a domed portion and a base underlying the domed portion;  
 an elongate shaft (101) extending from the base of the head;  
 an annular skirt (201) having a trailing edge (113) positioned furthest from the head and a leading edge (112) positioned closest to the head relative to a longitudinal axis of the shuttlecock;  
 radial spokes (111) extending from a region towards one end of the shaft furthest from the head and attached to the skirt;  
 wherein the leading edge of the skirt is separated from the head relative to the longitudinal axis of the shuttlecock by a distance along the length of the elongate shaft to provide a void axially between the head and the skirt;

### characterised in that:

the skirt is formed as a unitary body and each of the radial spokes is curved along its length in a radial direction between the shaft and skirt.

### 2. The shuttlecock as claimed in claim 1 wherein each spoke further comprises a curvature extending in the axial direction between the shaft and skirt.

3. The shuttlecock as claimed in any preceding claim wherein each spoke terminates at a common central boss having a mounting portion wherein the shaft is detachably mounted at the central boss via the mounting portion. 5
4. The shuttlecock as claimed in claim 2 wherein the curvature of each spoke in the radial direction comprises a concave and a convex region along its length. 10
5. The shuttlecock as claimed in a preceding claim wherein the spokes are formed integrally with the shaft. 15
6. The shuttlecock as claimed in any one of claims 1 to 5 wherein the spokes, the shaft and the skirt are formed integrally. 20
7. The shuttlecock as claimed in any preceding claim wherein each spoke comprises a blade-like configuration comprising a width extending perpendicular to the longitudinal axis and a depth extending in the longitudinal axis wherein the depth is greater than the width. 25
8. The shuttlecock as claimed in any preceding claim wherein each spoke comprises a twist along its length. 30
9. The shuttlecock as claimed in any preceding claim wherein the skirt comprises webbing extending between the leading and trailing edges. 35
10. The shuttlecock as claimed in any preceding claim wherein an outward facing surface of the skirt is convex between the leading and trailing edges. 40
11. The shuttlecock as claimed in any preceding claim wherein the skirt comprises a continuous annular configuration. 45
12. The shuttlecock as claimed in any preceding claim wherein the shuttlecock comprises any one or a combination of the following: 50
- a polyamide, preferably Nylon;
  - polypropylene;
  - polyethylene;
  - polystyrene;
  - polyvinyl chloride;
  - polytetrafluoroethylene PTFE);
  - polyester;
  - polylactic acid;
  - polyurethane;
  - an acrylic;
  - a polyester-polyether co-polymer. 55

13. A shuttlecock kit of parts comprising:

at least one head (100) having a domed portion and a base underlying the domed portion;  
 at least one elongate shaft (101) extending from the base of the head, said elongate shaft comprising an end (110), distal from the head, for attaching to a annular skirt; a plurality of annular skirts (201), each skirt having a trailing edge (113) positionable furthest from the head and a leading edge positionable closest to the head relative to a longitudinal axis of the shuttlecock;

**characterised by:**

radial spokes (111) extending inwardly from each skirt towards a longitudinal axis bisecting centrally each annular skirt, each spoke of each skirt being curved along its length in a radial direction between the shaft to the skirt;  
 wherein each skirt is formed as a unitary body and each spoke is attached to a region of a respective skirt, each skirt comprising a different respective shape and/or size such that the skirts may be interchanged with the at least one head to change the shape and/or size of the shuttlecock.

14. The kit of parts as claimed in claim 13 wherein each skirt is integrally formed with respective radial spokes and a respective shaft.
15. The kit of parts as claimed in claims 13 or 14 further comprising the at least one head mount section connectable to an end of the shaft, the head mount section configured to mount the base of the head.

**Patentansprüche**

1. Federball, umfassend:

einen Kopf (100), der einen gewölbten Abschnitt und  
 eine Basis, die unterhalb des gewölbten Abschnitts liegt, aufweist;  
 einen langgestreckten Schaft (101), welcher sich von der Basis des Kopfes ausgehend erstreckt;  
 eine ringförmige Schürze (201), die eine am weitesten vom Kopf entfernt angeordnete Hinterkante (113) und  
 eine dem Kopf am nächsten angeordnete Vorderkante (112) in Bezug zu einer Längsachse des Federballs aufweist;

radiale Speichen (111), welche sich von einem Bereich in Richtung eines Ende des



Schafts, das am weitesten von dem Kopf entfernt ist, erstrecken und an der Schürze befestigt sind;  
wobei die Vorderkante der Schürze von dem Kopf in Bezug auf die Längsachse des Federballes um einen Abstand entlang der Länge des langgestreckten Schafts getrennt ist um in axialer Richtung einen Hohlraum zwischen dem Kopf und der Schürze bereitzustellen;

**dadurch gekennzeichnet, dass:**

die Schürze als ein einkomponentiger Körper ausgebildet ist und jede der radialen Speichen der Länge nach in die radiale Richtung zwischen dem Schaft und der Schürze gekrümmt ist.

2. Federball nach Anspruch 1, wobei jede Speiche zusätzlich eine Krümmung umfasst, die sich in axialer Richtung zwischen dem Schaft und der Schürze erstreckt.
3. Federball nach einem der vorherigen Ansprüche, wobei jede Speiche an einem gemeinsamen zentralen Vorsprung, der ein Befestigungsteil aufweist, endet, wobei der Schaft abnehmbar an dem zentralen Vorsprung mittels dem Befestigungsteil befestigt ist.
4. Federball nach Anspruch 2, wobei die Krümmung von jeder Speiche in radiale Richtung einen konkaven und einen konvexen Bereich entlang ihrer Länge umfasst.
5. Federball nach einem der vorhergehenden Ansprüche, wobei die Speichen einstückig mit dem Schaft ausgebildet sind.
6. Federball nach einem der vorhergehenden Ansprüche 1 bis 5, wobei die Speichen, der Schaft und die Schürze einstückig ausgebildet sind.
7. Federball nach einem der vorhergehenden Ansprüche, wobei jede Speiche eine propellerblattartige Konfiguration, die eine Breite, die sich senkrecht zu der Längsachse, und eine Tiefe, die sich auf der Längsachse erstreckt, umfasst, wobei die Tiefe größer als die Breite ist.
8. Federball nach einem der vorhergehenden Ansprüche, wobei jede Speiche eine Verwindung entlang ihrer Länge umfasst.
9. Federball nach einem der vorhergehenden Ansprüche, wobei die Schürze eine Netzung zwischen der Vorder- und der Hinterkante aufweist.

10. Federball nach einem der vorhergehenden Ansprüche, wobei eine nach außen orientierte Oberfläche der Schürze konvex zwischen der Vorder- und der Hinterkante ist.
11. Federball nach einem der vorhergehenden Ansprüche, wobei die Schürze eine durchgängige ringförmige Konfiguration umfasst.
12. Federball nach einem der vorhergehenden Ansprüche, wobei der Federball eines oder eine Kombination der folgenden umfasst:

ein Polyamid, vorzugsweise Nylon;  
Polypropylen;  
Polyethylen;  
Polystyren;  
Polyvinylchlorid;  
Polytetrafluorethylen (PTFE);  
Polyester;  
Polylactide;  
Polyurethane;  
ein Acryl;  
ein Polyester-Polyether Copolymer.

**13. Federball-Teilesatz, umfassend:**

zumindest einen Kopf (100), der einen gewölbten Abschnitt und eine Basis, die unterhalb des gewölbten Abschnitts liegt, aufweist;

zumindest einen langgestreckten Schaft (101), welcher sich von der Basis des Kopfes ausgehend erstreckt, wobei der langgestreckte Schaft ein Ende (110), entfernt von dem Kopf, zum Anbringen an die ringförmige Schürze, aufweist;  
eine Vielzahl von ringförmigen Schürzen (201), wobei jede Schürze eine Hinterkante (113), die am weitesten vom Kopf entfernt anordbar ist und eine Vorderkante, die dem Kopf am nächsten in Bezug zu einer Längsachse des Federballes anordbar ist, umfasst;

**gekennzeichnet durch:**

radiale Speichen (111), die sich nach innen von jeder Schürze in Richtung einer Längsachse erstrecken, mittig jede ringförmige Schürze halbiert, wobei jede Speiche jeder Schürze ihrer Länge nach in eine radiale Richtung zwischen dem Schaft und der Schürze gekrümmt ist;  
wobei jede Schürze als ein einkomponentiger Körper ausgebildet ist und jede Speiche an einen

Bereich von einer jeweiligen Schürze befestigt ist, wobei jede Schürze eine verschiedene jeweilige Form und/oder Größe umfasst, so dass die Schürzen mit dem zumindest einen Kopf ausgetauscht werden können um die Form und/oder die Größe des Federballs zu ändern.

14. Teilesatz nach Anspruch 13, wobei jede Schürze einstückig mit den jeweiligen radialen Speichen und einem jeweiligen Schaft ausgebildet ist.
15. Teilesatz nach Anspruch 13 oder 14, zusätzlich umfassend den zumindest einen Kopfbefestigungsabschnitt, der mit einem Ende des Schafts verbunden werden kann, wobei der Kopfbefestigungsabschnitt eingerichtet ist, die Basis des Kopfs zu befestigen.

### Revendications

1. Volant de badminton comprenant :

une tête (100) ayant une portion en dôme et une base sous la portion en dôme ;  
 une tige allongée (101) s'étendant depuis la base de la tête ;  
 une jupe annulaire (201) ayant un bord arrière (113) positionné le plus loin de la tête et un bord avant (112) positionné le plus près de la tête par rapport à un axe longitudinal du volant de badminton ;  
 des rayons radiaux (111) s'étendant depuis une région vers une extrémité de la tige le plus loin de la tête et attachés à la jupe ;  
 dans lequel le bord avant de la jupe est séparé de la tête par rapport à l'axe longitudinal du volant de badminton d'une distance suivant la longueur de la tige allongée pour fournir un vide axialement entre la tête et la jupe ;

#### caractérisé en ce que :

la jupe est sous forme de corps monobloc et chacun des rayons radiaux est incurvé suivant sa longueur dans une direction radiale entre la tige et la jupe.

2. Volant de badminton selon la revendication 1, dans lequel chaque rayon comprend en outre une courbure s'étendant dans la direction axiale entre la tige et la jupe.
3. Volant de badminton selon une quelconque revendication précédente, dans lequel chaque rayon se termine au niveau d'un bossage central commun

ayant une portion de montage dans lequel la tige est montée amovible au niveau du bossage central via la portion de montage.

- 5 4. Volant de badminton selon la revendication 2, dans lequel la courbure de chaque rayon dans la direction radiale comprend une région concave et une région convexe suivant sa longueur.
- 10 5. Volant de badminton selon une revendication précédente, dans lequel les rayons sont formés d'un seul tenant avec la tige.
- 15 6. Volant de badminton selon l'une quelconque des revendications 1 à 5, dans lequel les rayons, la tige et la jupe sont formés d'un seul tenant.
- 20 7. Volant de badminton selon une quelconque revendication précédente, dans lequel chaque rayon comprend une configuration de type lame comprenant une largeur s'étendant perpendiculaire à l'axe longitudinal et une profondeur s'étendant dans l'axe longitudinal dans lequel la profondeur est supérieure à la largeur.
- 25 8. Volant de badminton selon une quelconque revendication précédente, dans lequel chaque rayon comprend une torsion suivant sa longueur.
- 30 9. Volant de badminton selon une quelconque revendication précédente, dans lequel la jupe comprend une sangle s'étendant entre les bords avant et arrière.
- 35 10. Volant de badminton selon une quelconque revendication précédente, dans lequel une surface faisant face vers l'extérieur de la jupe est convexe entre les bords avant et arrière.
- 40 11. Volant de badminton selon une quelconque revendication précédente, dans lequel la jupe comprend une configuration annulaire continue.
- 45 12. Volant de badminton selon une quelconque revendication précédente, dans lequel le volant de badminton comprend l'un quelconque ou une combinaison de ce qui suit :
- 50 un polyamide, de préférence du nylon ;  
 un polypropylène ;  
 un polyéthylène ;  
 un polystyrène ;  
 un polychlorure de vinyle ;  
 un polytétrafluoroéthylène (PTFE) ;
- 55 un polyester ;  
 un polyacide lactique ;  
 un polyuréthane ;  
 un acrylique ;

un copolymère polyester-polyéther.

**13.** Kit de pièces de volant de badminton comprenant :

au moins une tête (100) ayant une portion en dôme et une base sous la portion en dôme ; 5  
 au moins une tige allongée (101) s'étendant depuis la base de la tête, ladite tige allongée comprenant une extrémité (110), distale de la tête, pour s'attacher à une jupe annulaire ; 10  
 une pluralité de jupes annulaires (201), chaque jupe ayant un bord arrière (113) positionnable le plus loin de la tête et un bord avant positionnable le plus près de la tête par rapport à un axe longitudinal du volant de badminton ; 15

**caractérisé par :**

des rayons radiaux (111) s'étendant vers l'intérieur depuis chaque jupe vers un axe longitudinal croisant au centre chaque jupe annulaire, chaque rayon de chaque jupe étant incurvé suivant sa longueur dans une direction radiale entre la tige et la jupe ; 20  
 dans lequel chaque jupe est sous forme de corps monobloc et chaque rayon est attaché à une région d'une jupe respective, chaque jupe comprenant une forme et/ou une taille respectives différentes de sorte que les jupes puissent être interchangeables avec l'au moins une tête pour changer la forme et/ou la taille du volant de badminton. 30

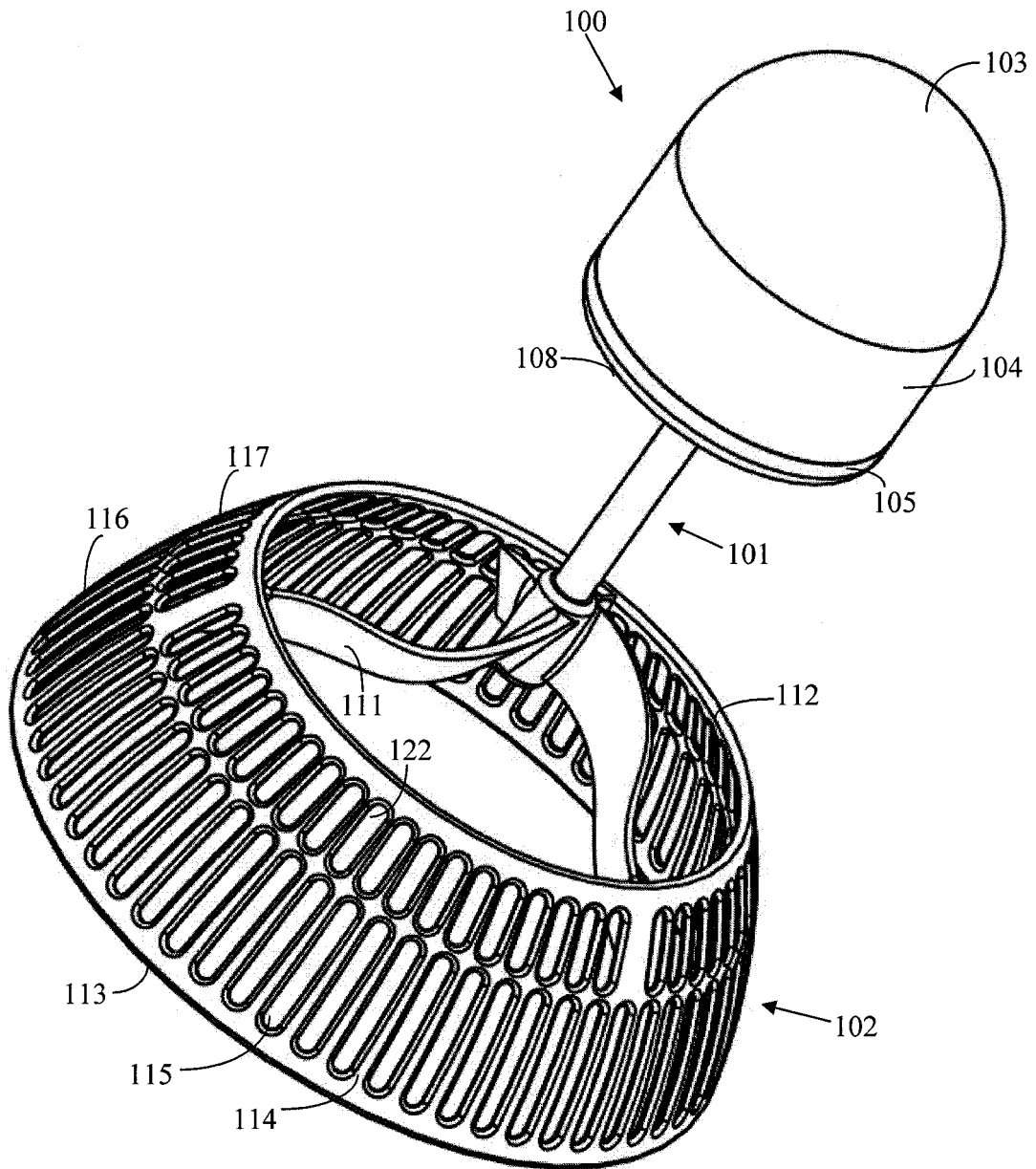
**14.** Kit de pièces selon la revendication 13, dans lequel chaque jupe est formée d'un seul tenant avec des rayons radiaux respectifs et une tige respective. 35

**15.** Kit de pièces selon les revendications 13 ou 14, comprenant en outre l'au moins une section de montage de tête raccordable à une extrémité de la tige, la section de montage de tête étant configurée pour monter la base de la tête. 40

45

50

55



**Fig. 1A**

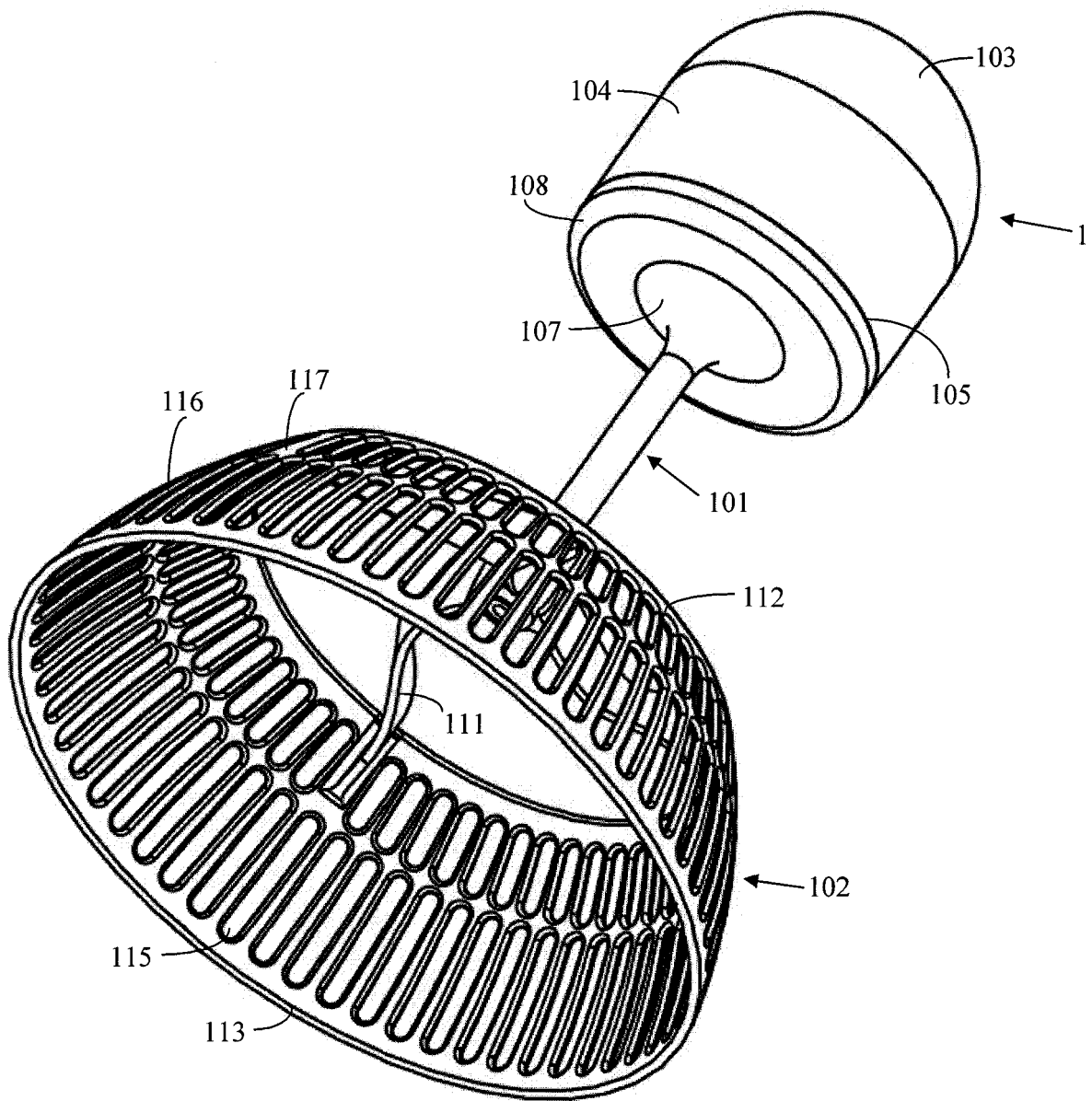
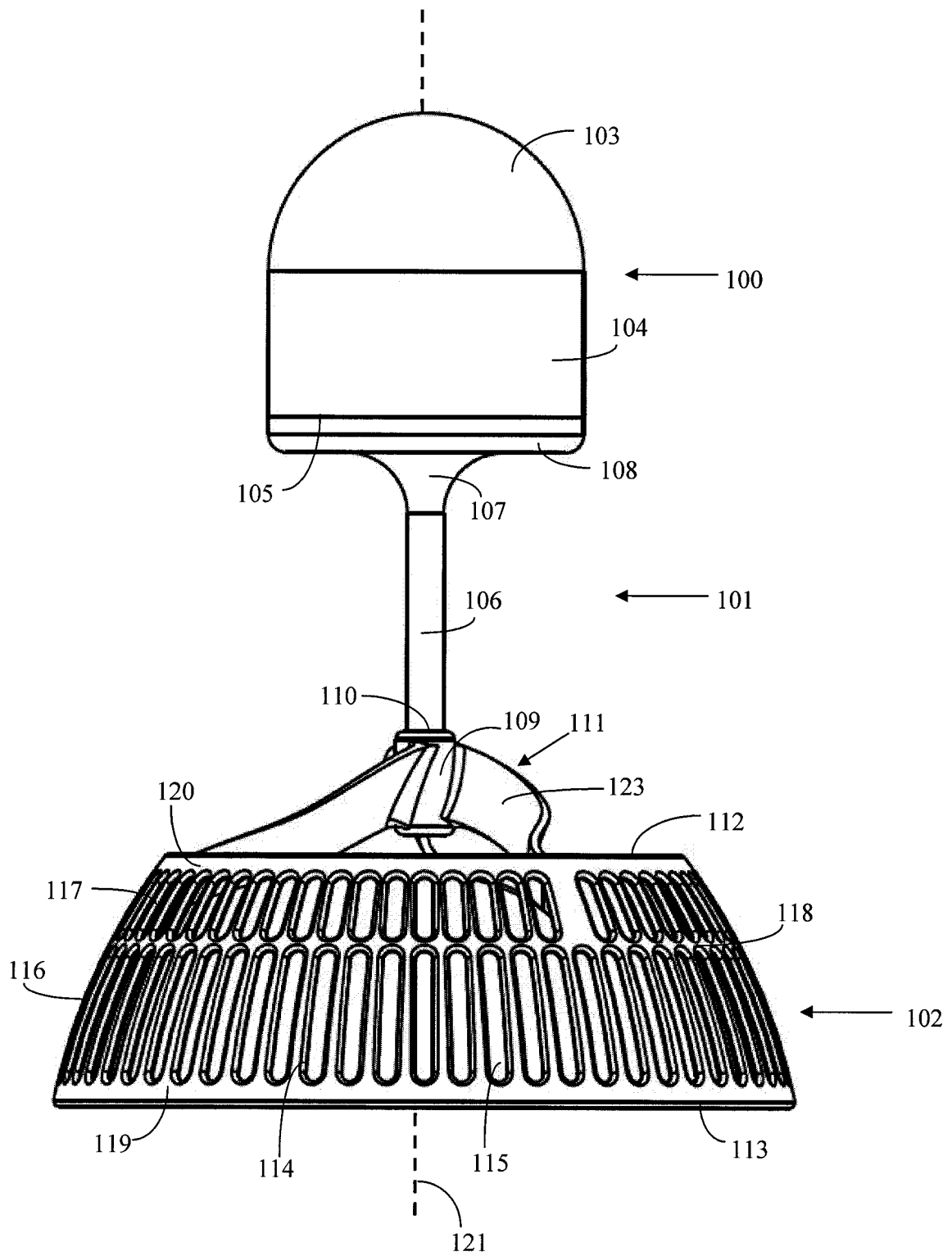
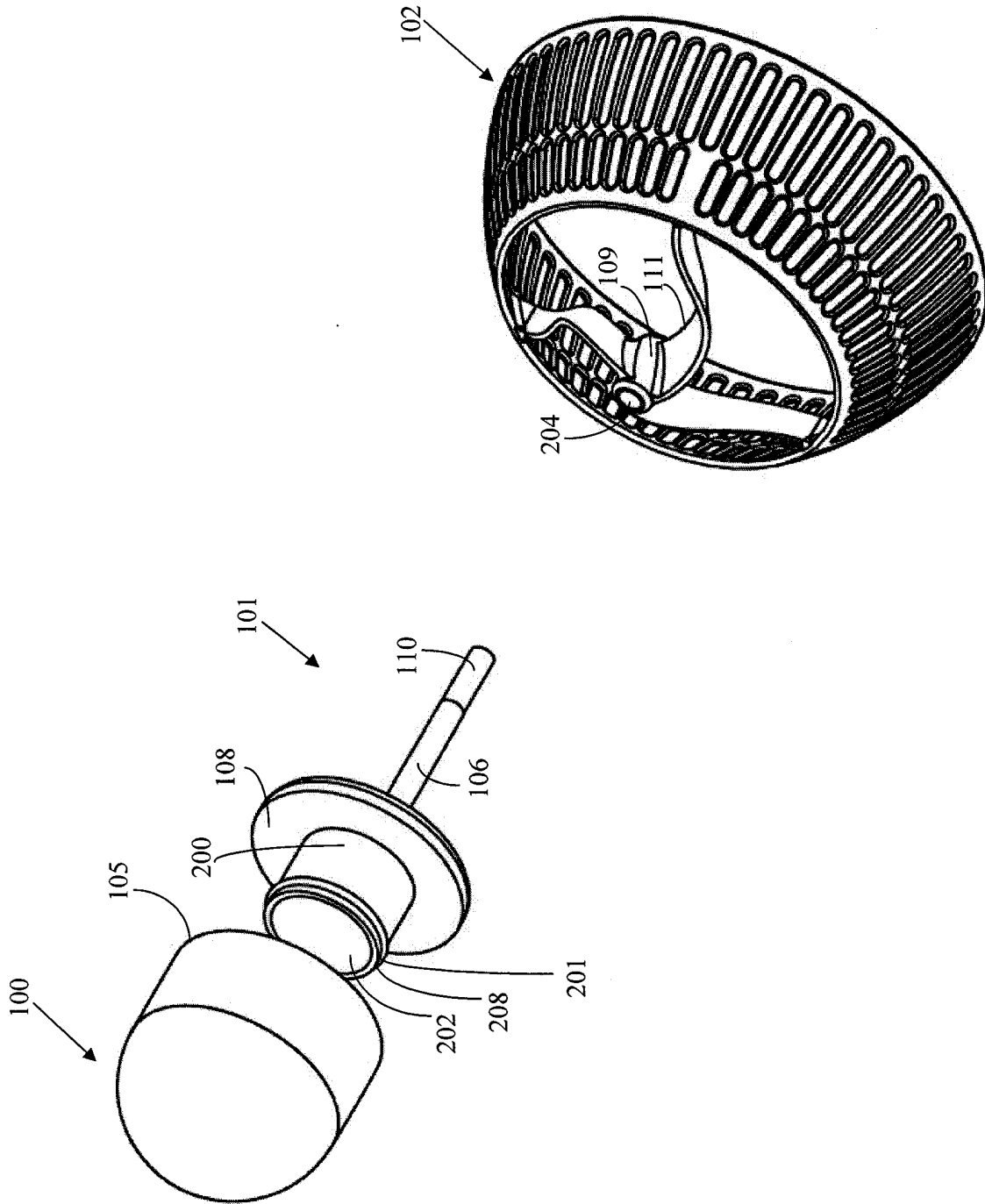


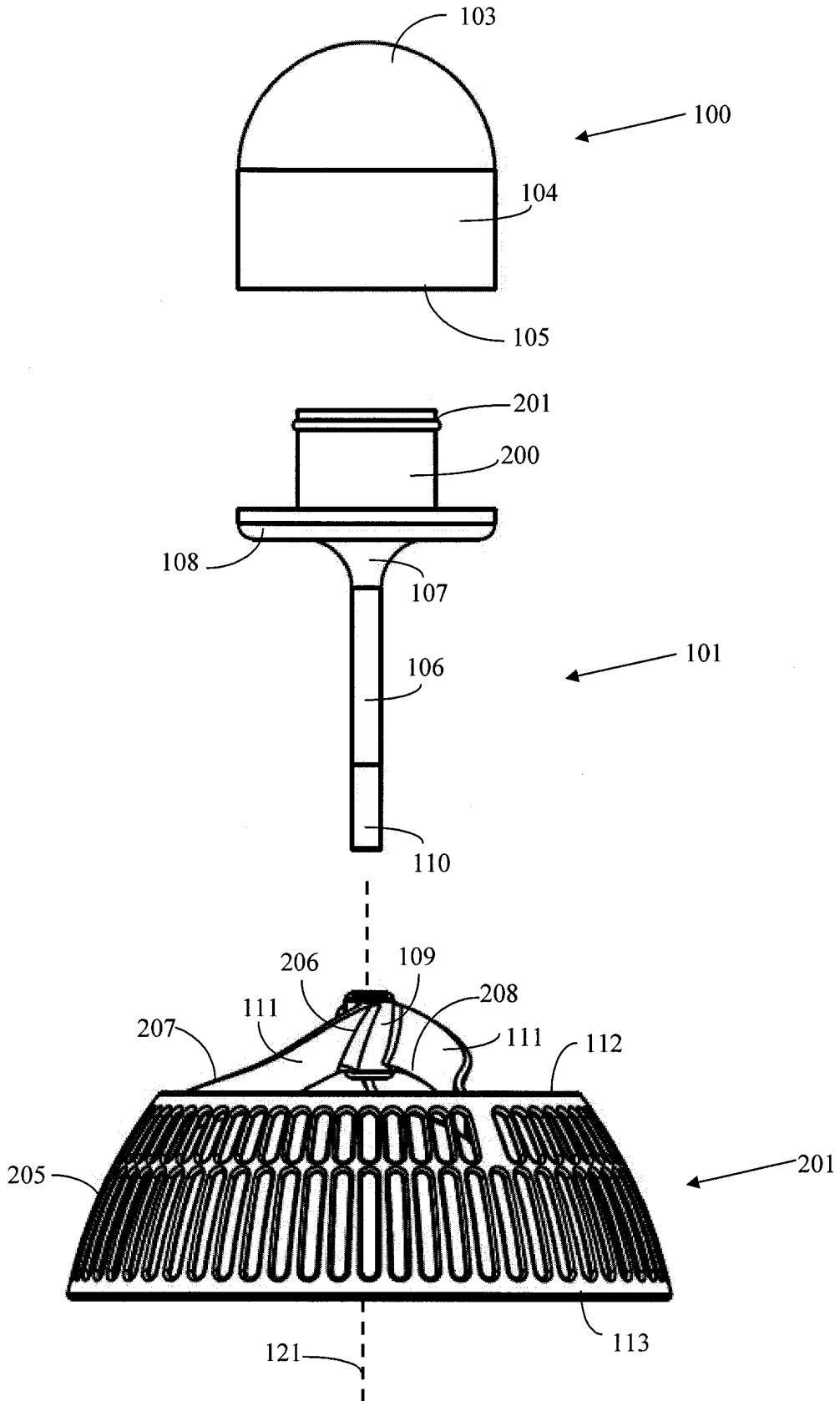
Fig. 1B



**Fig. 1C**

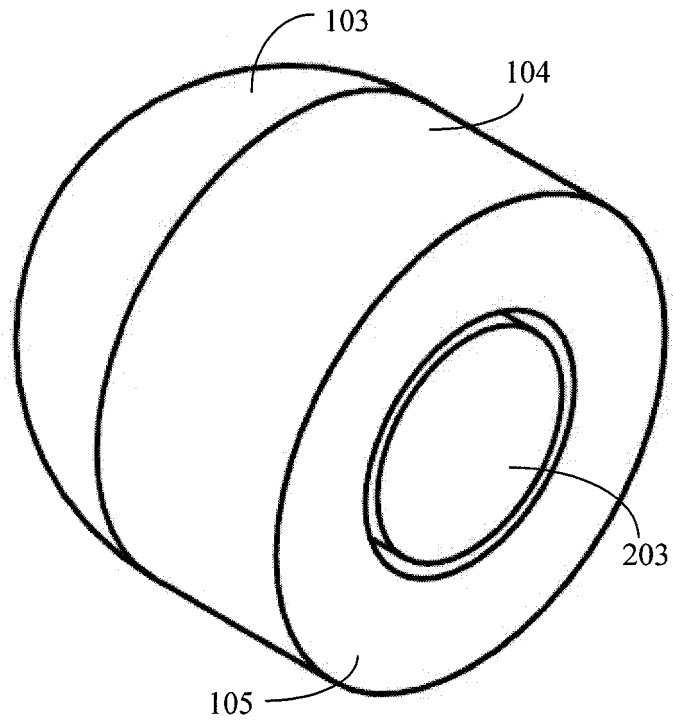


**Fig. 2A**



**Fig. 2B**





**Fig. 2C**

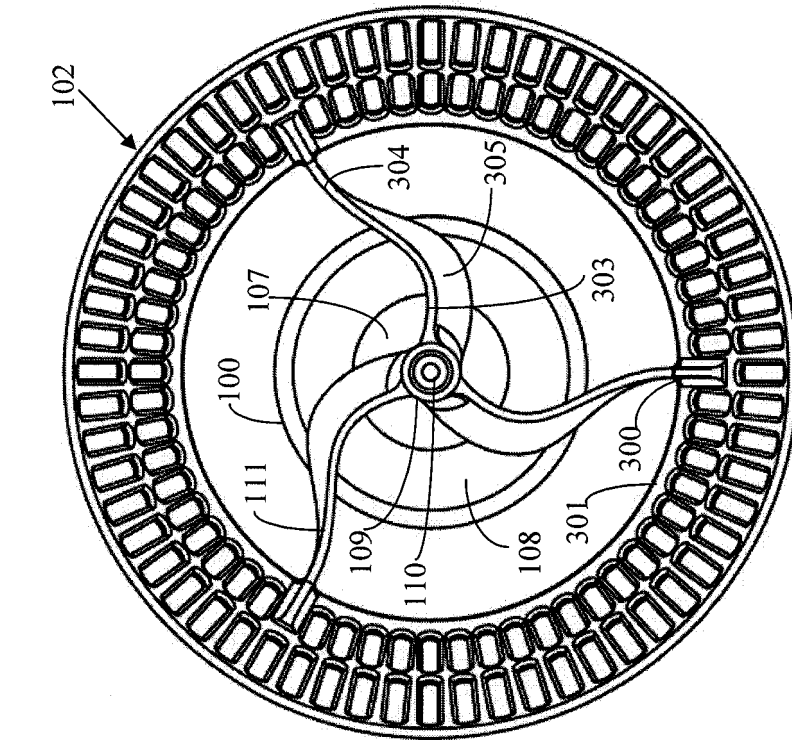


Fig. 3A

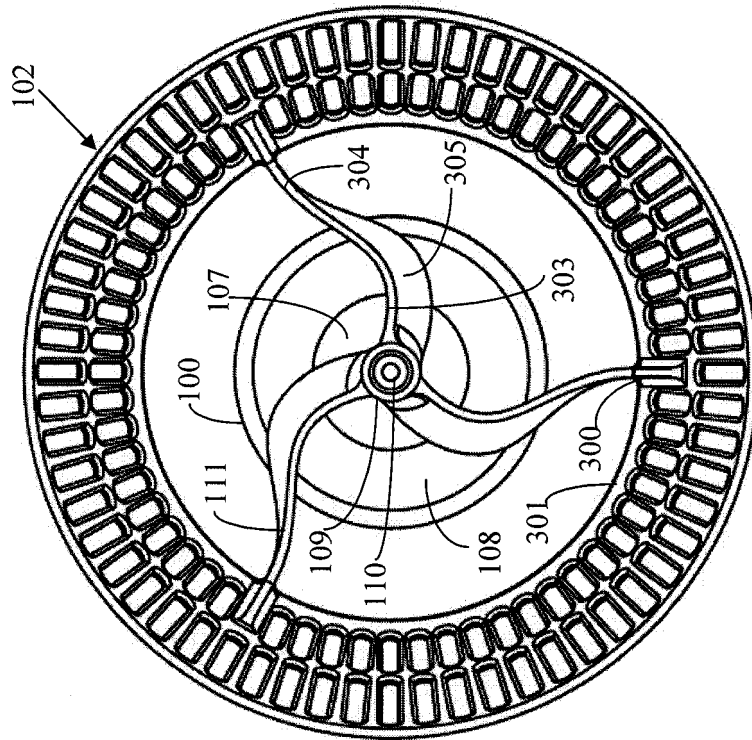


Fig. 3B

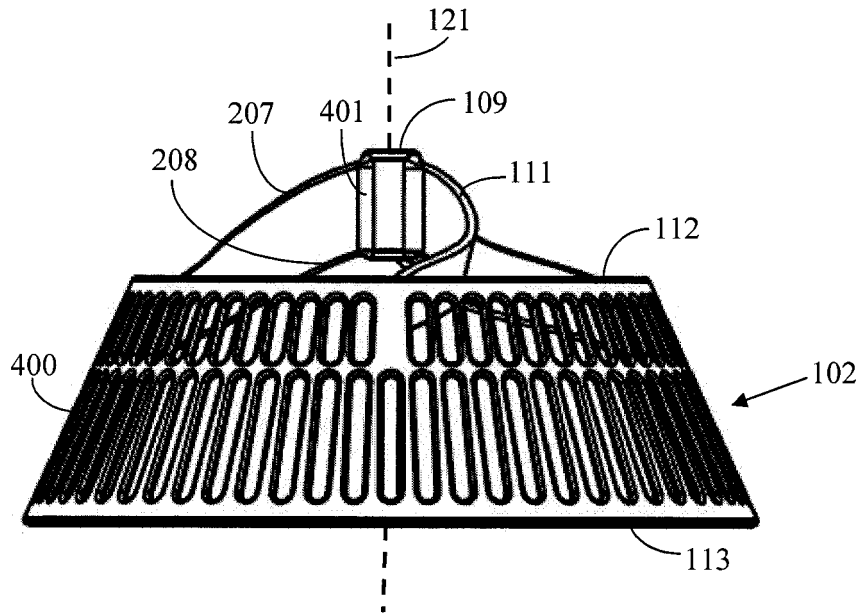


Fig. 4A

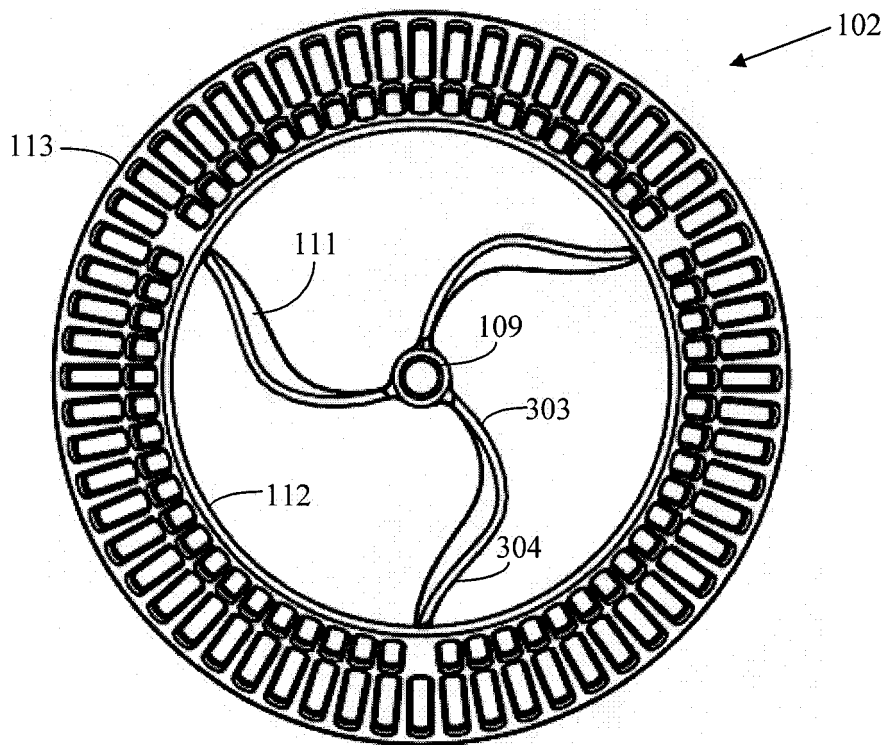


Fig. 4B

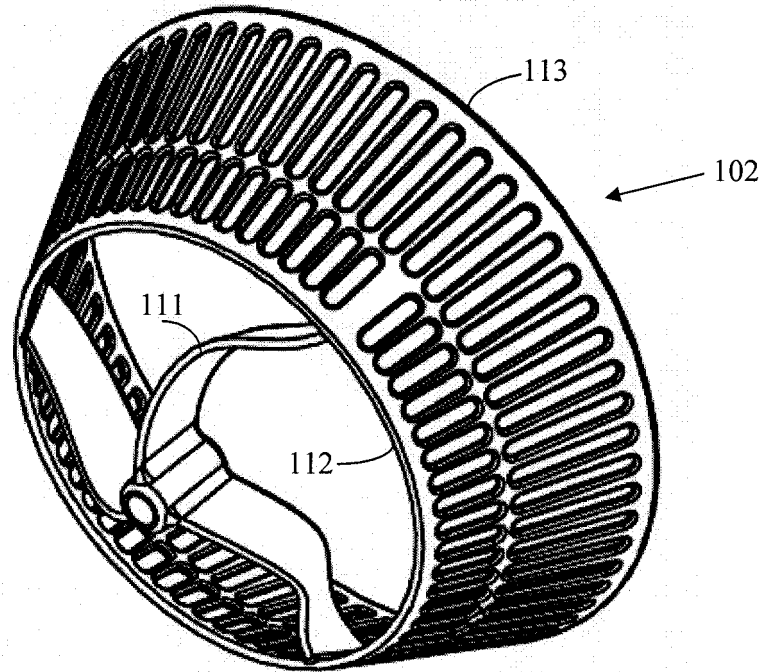


Fig. 4C

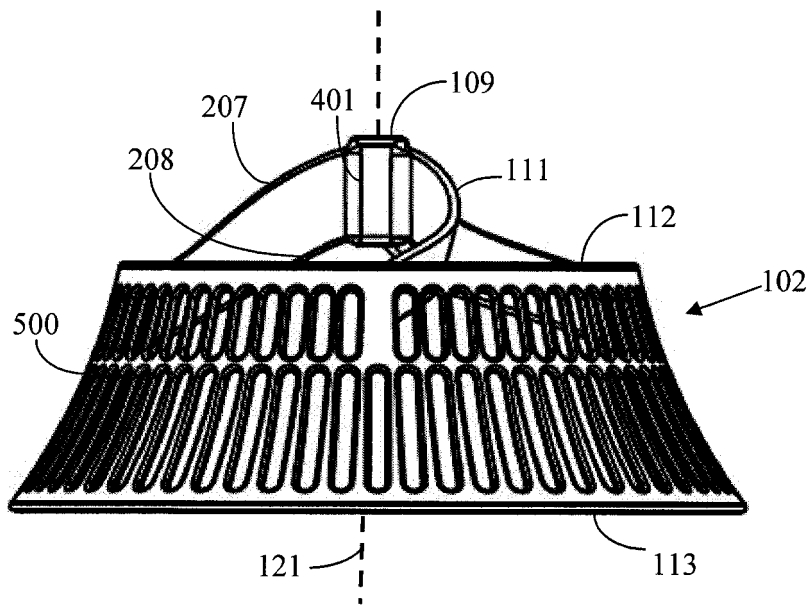
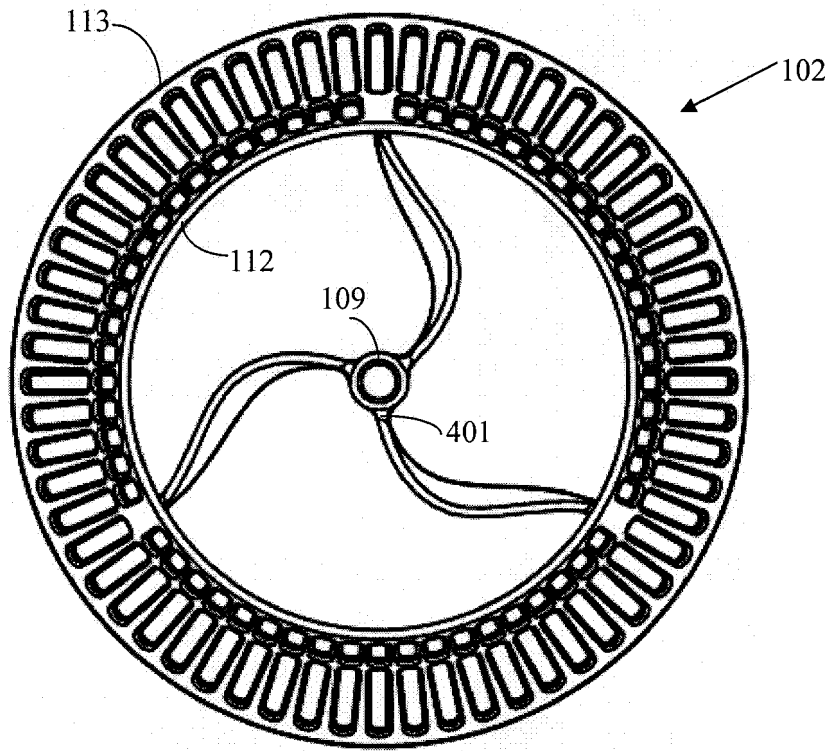
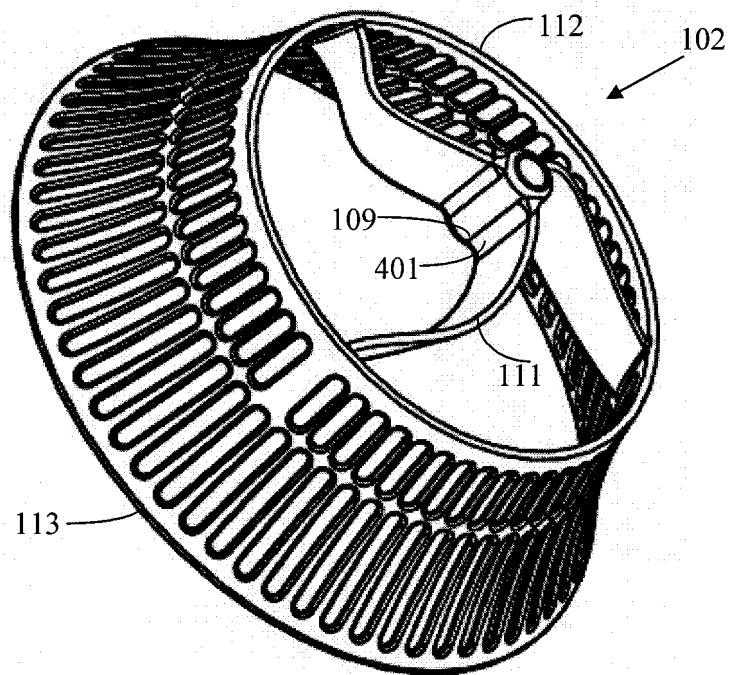


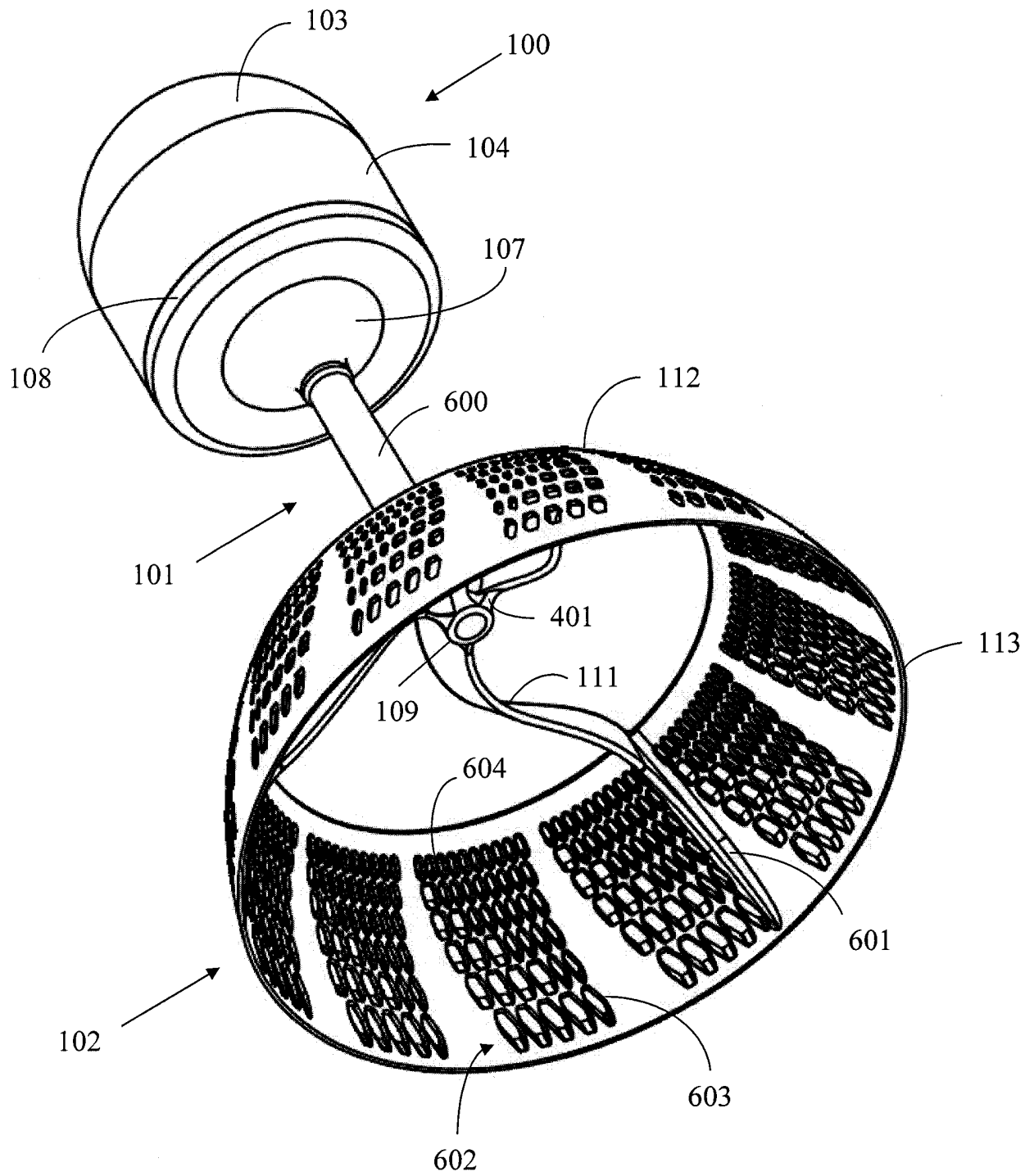
Fig. 5A



**Fig. 5B**



**Fig. 5C**



**Fig. 6**

Fig. 7A

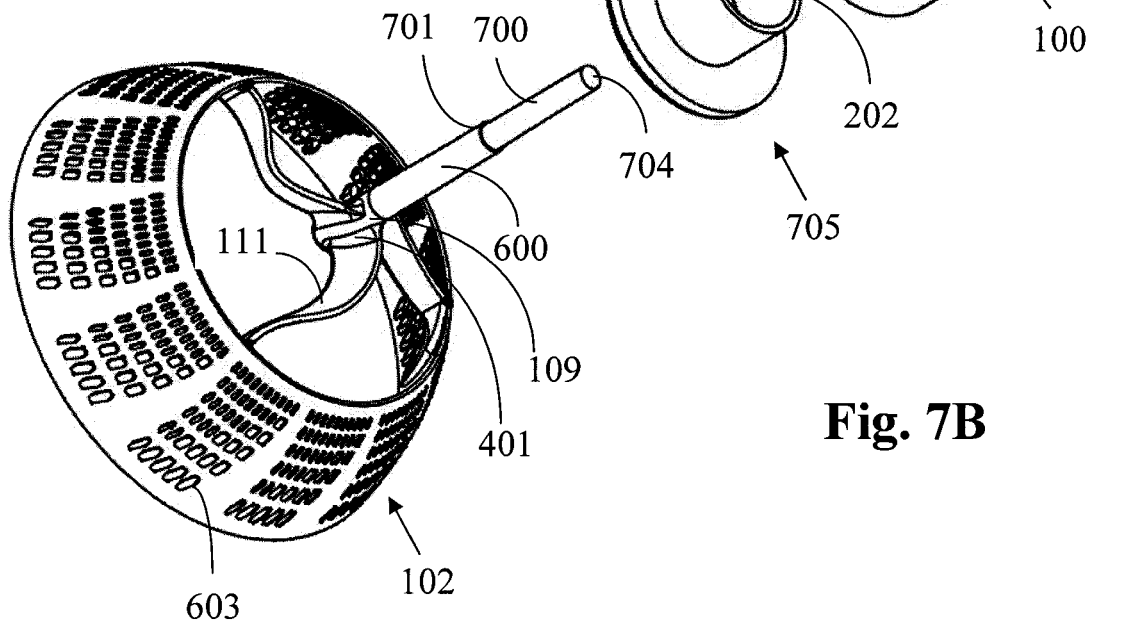
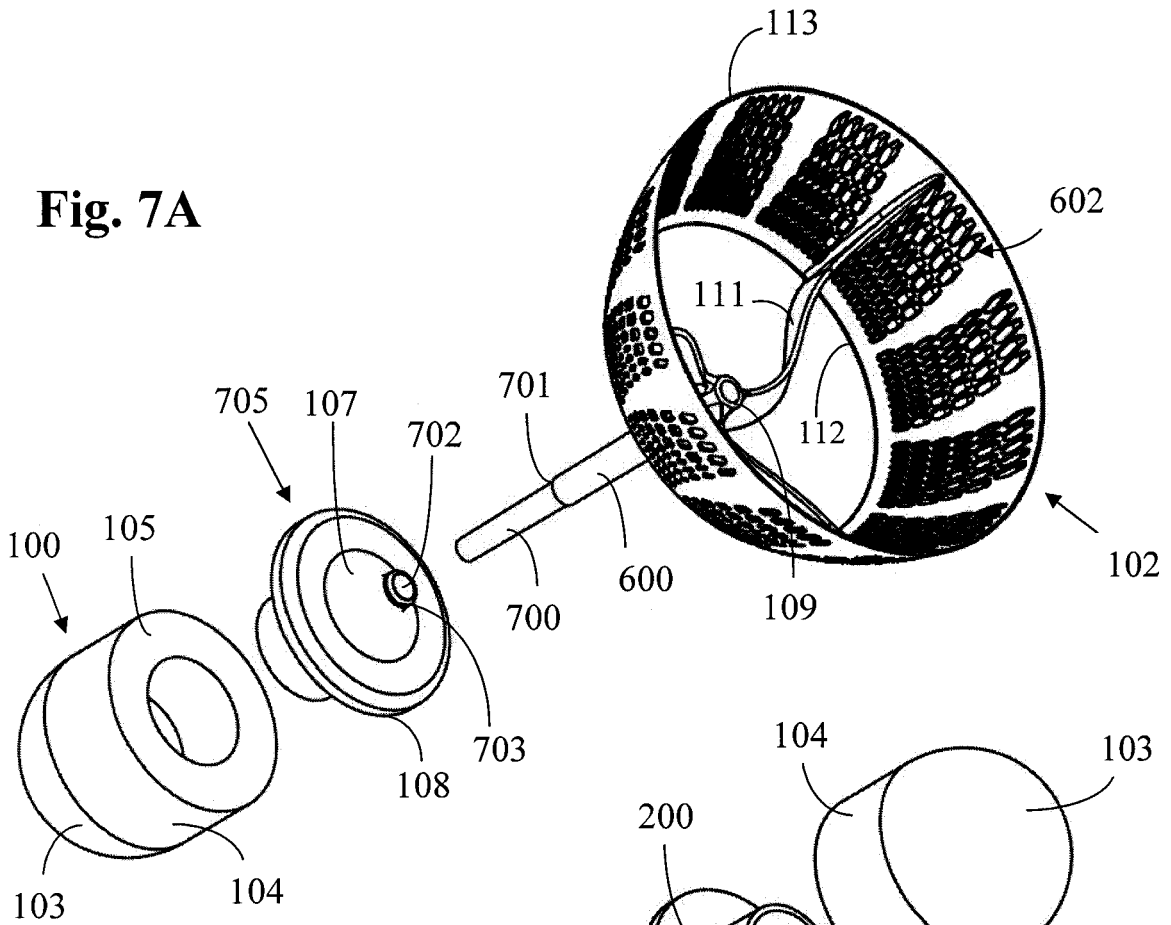


Fig. 7B

**REFERENCES CITED IN THE DESCRIPTION**

*This list of references cited by the applicant is for the reader's convenience only. It does not form part of the European patent document. Even though great care has been taken in compiling the references, errors or omissions cannot be excluded and the EPO disclaims all liability in this regard.*

**Patent documents cited in the description**

- CA 388507 [0005]
- US 2218593 A [0005]
- US 2302845 A [0005]
- US 2247486 A [0005]
- US 3752479 A [0005]
- WO 8400306 A [0005]
- FR 2594039 [0005]
- US 4519613 A [0005]
- FR 2615745 [0005]
- DE 4005918 [0005]
- DE 19646508 [0005]
- US 5860879 A [0005]
- US 6315687 B [0005]
- US 6709353 B [0005]
- CN 201195035 [0005]
- CN 2863200 [0005]
- FR 2890870 [0005]
- DE 102005039121 [0005]
- CN 201105139 [0005]
- CN 201200778 [0005]
- CN 201768335 [0005]
- GB 1543635 A [0005]
- CN 201815075 [0005]
- GB 926049 A [0005]
- US 3359002 A [0005]
- DE 202010006986 [0005]
- JP 54039176 B [0005]
- CN 201768335 U [0006]