

Doppler ultrasound flow measurement of non-parallel velocity fields in a deformed elastic tube

DUBEY, Bipro <<http://orcid.org/0000-0003-0396-9864>>, NAHAR, Samsun and WINDHAB, Erich

Available from Sheffield Hallam University Research Archive (SHURA) at:

<https://shura.shu.ac.uk/27192/>

This document is the Accepted Version [AM]

Citation:

DUBEY, Bipro, NAHAR, Samsun and WINDHAB, Erich (2020). Doppler ultrasound flow measurement of non-parallel velocity fields in a deformed elastic tube. *International Journal of Hydromechatronics*, 3 (4), 368-384. [Article]

Copyright and re-use policy

See <http://shura.shu.ac.uk/information.html>

Doppler ultrasound flow measurement of non-parallel velocity fields in a deformed elastic tube

Bipro N. Dubey^{*,1}, S. Nahar¹, and Erich J. Windhab

Laboratory of Food Process Engineering, Institute of Food, Nutrition and Health, ETH Zurich, Schmelzbergstrasse 9, 8092 Zurich, Switzerland.

Abstract: The ultrasonic Doppler velocimetry (UVP) method is well known for the laminar flow stream in a circular tube. In many practical situations, deformed tubes or, non-parallel streamlines are involved. An improved experimental arrangement of the UVP transducer is needed to define the real velocity-vectors of the flow when the streamlines are not parallel to its wall. An experimental approach has been used with two sets of transducers in perpendicular to each other to obtain the magnitude of the real velocity vector (v_{real}), the direction of velocity-vector, and axial velocity component along the flow direction. The experiments were carried out using a proposed arrangement of UVP transducer for flow visualization in a squeezed elastic tube. The results show that the 2D velocity profiling found to be more accurate using the present transducer arrangement, which is important for generating further information such as shear rate, flow rate, etc.

Keywords: Ultrasound Doppler velocimetry, contraction flow geometry, non-parallel flow, velocity vector, elastic tube.

1. Introduction:

The UVP (ultrasonic velocity profiling) is a unique measuring method for monitoring velocity profile in a liquid phase (Takeda 1986, Takeda 1987, Met-Flow 2002, Ouriev and Windhab 2002, Takeda and Kikura 2002, Birkhofer 2007, Birkhofer, Jeelani et al. 2008, Nahar, Dubey et al. 2019). This method is advantageous due to its wider range of applicability (Takeda 1986, Choi, McCarthy et al. 2002, Wiklund, Stading et al. 2006, Wiklund, Shahram et al. 2007, Birkhofer, Jeelani et al. 2008, Kotzé, Wiklund et al. 2011, Nahar, Jeelani et al. 2012a, Dong, Gao et al. 2019) such as non-invasive to the investigated fluid, easy implementation, opaque liquid flow investigation, inexpensive, and portable compared to other popular methods such as Magnetic Resonance Imaging (MRI), Particle Image Velocimetry (PIV), Electrical Impedance Tomography (EIT), Laser Doppler Anemometry (LDA), X-ray radiography, and neutron radiography, etc. (Wiklund, Stading et al. 2006, Wang, Lee et al. 2016). Since the method can measure an instantaneous velocity profile along a measurement line using the Doppler shift frequency analysis due to the fact of the reflection of ultrasound from the moving particles or macromolecule in the fluid (Takeda 1986, Takeda 1987, Met-Flow 2002). UVP only provides information on the velocity vector component along the measuring line. This method can precisely identify the velocity profile while fluid flow in a circular tube. A simplified approach is used to obtain the corresponding velocity vector in the flow direction by angle correction (Takeda 1986, Takeda 1987, Met-Flow 2002, Takeda and Kikura 2002) as shown in Fig. 1. This correction seems to be only valid when the streamlines are parallel or flow is parallel to the tube wall. The correction is only valid for the real velocity vector which makes an angle of $90^\circ - \theta$ (Fig. 1) with the

^{*}Corresponding author: Email: b.dubey@shu.ac.uk, Phone: +441142254782. ¹Present address: College of Business, Technology and Engineering, Department of Engineering and Mathematics, Sheffield Hallam University, Howard Street, Sheffield, S1 1WB, UK.

measuring line that can only be obtained for a parallel velocity vector to the wall. There are many practical circumstances, where deformed tubes or, non-parallel streamlines are involved, and they never are parallel to the wall. In general, the flow mapping and shear stress estimation are required in many complex geometries such as heat exchanger, pump, contraction, expansion, elbow, valve, nozzle, Couette flow, continuous stirring tank (CST), and orifice, etc. for various industrial applications (Takeda and Kikura 2002, Nahar, Jeelani et al. 2012a, Nahar, Jeelani et al. 2012b, Kotzé and Wiklund 2014, Kozlovsky, Zaretsky et al. 2014, Windhab 2014, Takahisa, Yuji et al. 2015, Wang, Lee et al. 2016, Haya and Tavoularis 2017, Liu, Zhang et al. 2017, Yoshida, Tasaka et al. 2017, Ala, Tan et al. 2019, Alokaily, Feigl et al. 2019, Bashir, Everts et al. 2019, Islam, Ehiraj et al. 2019, Lu, Ferri et al. 2019, Nahar, Dubey et al. 2019, Tiwari, Tasaka et al. 2019).

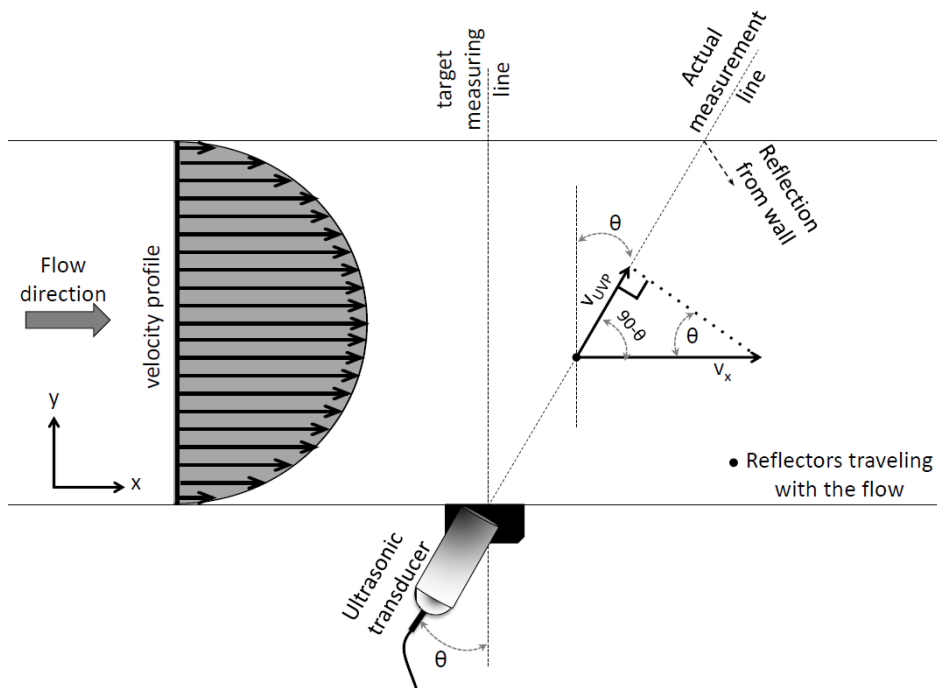

Figure 1: A schematic diagram of the UVP measurement technique (Takeda 1986, Met-Flow 2002) for velocity profile determination.

The UVP technique uses a single transducer which cannot be applicable for these complex flow circumstances to obtain the accurate velocity profile or estimate the corresponding stresses. Several recent researches (Takeda and Kikura 2002, Kotzé, Wiklund et al. 2011, Nahar, Jeelani et al. 2012a, Nahar, Jeelani et al. 2012b, Nahar, Jeelani et al. 2013, Takahisa, Yuji et al. 2015, Ala, Tan et al. 2019, Lu, Ferri et al. 2019, Nahar, Dubey et al. 2019, Tiwari, Tasaka et al. 2019) involve complex geometries for finding velocity or shear rate profiles, where UVP technique is applied while using a single transducer. Moreover, many authors are using UVP for velocity profile measurement to estimate in-line rheological property, pressure drop and flow stresses in both simple or complex geometries (Hughes and How 1993, Choi, McCarthy et al. 2002, Ouriev and Windhab 2002, Wiklund, Shahram et al. 2007, Birkhofer 2011, Kotzé, Wiklund et al. 2011, Tanner, Al-Hababbeh et al. 2012, Nahar, Jeelani et al. 2012a, Kotzé, Haldenwang et al. 2015, Takahisa, Yuji et al. 2015, Berta, Wiklund et al. 2016,

Yoshida, Tasaka et al. 2017, Lu, Ferri et al. 2019, Tiwari, Tasaka et al. 2019). Accurate velocity profile estimation by UVP is required before further data processing. Although the limitation of UVP is known to the researchers (Kotzé, Wiklund et al. 2011, Wada, Tezuka et al. 2013), where they considered the error to be insignificant while using in a deformed tube or implemented multiple transducers and more computation effort (Takahisa, Yuji et al. 2015, Yoshida, Tasaka et al. 2017). In most of the complex flow systems, the error can be significantly high without considering the non-parallel flow. However, the UVP method has been improved using multiple transducers by several researchers (Takeda 1987, Takeda and Kikura 2002) for flow mapping in complex geometry, which requires more complex set-up (inapplicable for many practical applications) and computational effort. They have used multiple UVP-transducers to obtain true velocity vectors in a complex flow system. A simple experimental technique will be beneficial to define the real flow velocity-vectors for non-parallel flow in complex geometries.

The present study outlines a new UVP experimental technique to predict the velocity profile in a collapsed or squeezed elastic tube (non-parallel flow) for determining accurately the non-parallel velocity vector (v_{real}) (along the target measuring line), the axial velocity component (v_x) in the flow direction, and estimate a relatively accurate velocity profile. The experimental technique has been demonstrated to visualize a gradual contraction flow in a squeezed elastic tube, which is a trough in an intestinal peristaltic motion (Nahar, Jeelani et al. 2012b). The experimental result depicts the actual velocity vector profile (non-parallel to the tube wall) and the corresponding velocity component along the flow direction in a deformed elastic tube. An extended application of the proposed approach can be implemented for many other complex flow systems as well as other Doppler based velocity profiling methods.

2. The principle of UVP and applicability:

The UVP principle has been described in detail elsewhere (Takeda 1986, Met-Flow 2002, Birkhofer 2007, Tasaka, Birkhofer et al. 2012) for determining a velocity profile. The pulsed Ultrasound Doppler Velocimetry is a well-known and non-invasive method that measures an instantaneous velocity profile along the ultrasonic beam axis in a liquid flow field (Takeda 1986). A schematic representation of the principle of the UVP methods has been illustrated in Fig. 1. The schematic represents how a single transducer UVP method is used in a circular tube. The transducer transmits a sinusoidal ultrasonic pulse which eventually travels through the flowing fluid and the ultrasonic pulse hits on a reflective surface (usually small moving particle suspended or macromolecule flowing with the fluid), and the ultrasound partly echoes back. A time interval switching of the transducer mode between transmitter and receiver allows a Doppler shift for a non-zero velocity component of moving particle. The Doppler-shifted frequency is determined after demodulation using either time-domain or frequency-domain based signal processing (Wiklund, Shahram et al. 2007). The local velocity v_x in each channel in the flow direction is determined by (Fig. 1):

$$v_x = \frac{cf_D}{2f_e \sin \theta} = \frac{v_{UVP}}{\sin \theta} \quad (1)$$

Where c is the sound velocity in the medium, f_D is the Doppler-shifted frequency, f_e is the ultrasound emission frequency, θ is the angle between the incident beam and vertical axis, and v_{UVP} is the velocity components along the UVP beam axis.

2.1. Inapplicability of the general measurement approach of UVP for the nonparallel flow stream

Using single-transducer UVP method, the liquid velocity profile in a circular tube can be determined as illustrated in Fig. 1. The velocity component (v_{UVP}) of the true velocity vector ($v_{real} \approx v_x$) along the measurement axis can be obtained by Doppler-shifted echo-signal and requires an angle correction to obtain the velocity vector in the flow direction using equation (1) due to parallel streamlines (and parallel to the wall).

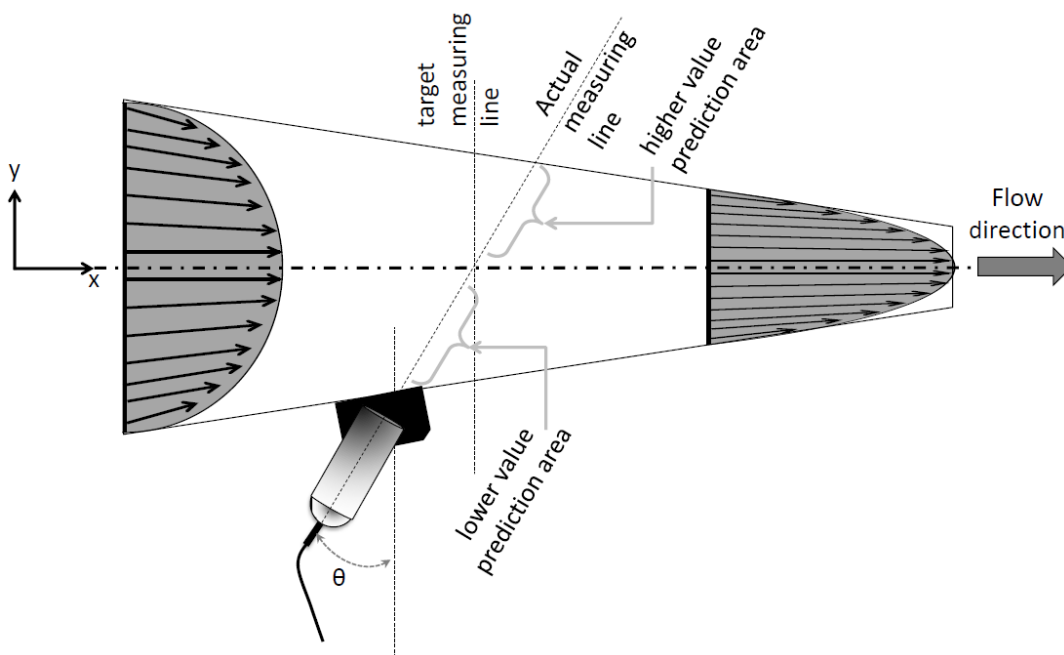

Figure 2: A schematic diagram of a contraction tube geometry, where an increase in velocity can be found along tube length (showing the higher and lower velocity prediction area along the target measuring line).

In addition, the velocity profile in the actual measuring line is found to be the same as the target measurement line. In Fig. 2, an example of a contraction tube (non-parallel flow situation) with the infinitely thin wall (considering no wall effect) is represented to better understand the inapplicability of UVP using a single transducer. The average velocity is approximated to increase by about 23.5% in a contraction tube due to decrease in diameter by only 10 % at a given flow rate (Hint: $\dot{Q} = \bar{v}_1 \pi r_1^2 = \bar{v}_2 \pi r_2^2$), where r_1 and r_2 are radii of a tube at inlet and outlet respectively, \bar{v}_1 and \bar{v}_2 being the corresponding average velocities). Therefore, the assumption of the equivalent velocity profile along actual and target measuring line is not valid anymore for a contraction tube or any complex geometry, where the diameter changes over length. It can be seen in Fig. 2 that most of the measuring flow streamlines are either under or over predicted due to the adjusted Doppler angle. Using a single transducer in a contraction flow (Fig. 2), the measured velocity will be under-predicted in the first half of the tube from the

transducer, and vice-versa. By tuning the Doppler angle, the error cannot be reduced enough due to the accuracy reasons. As shown in Fig. 3, non-parallel stream-lines are tilted with the axial flow direction (Fig. 3) due to the contraction flow, therefore, the standard UVP angle correction leads to an error.

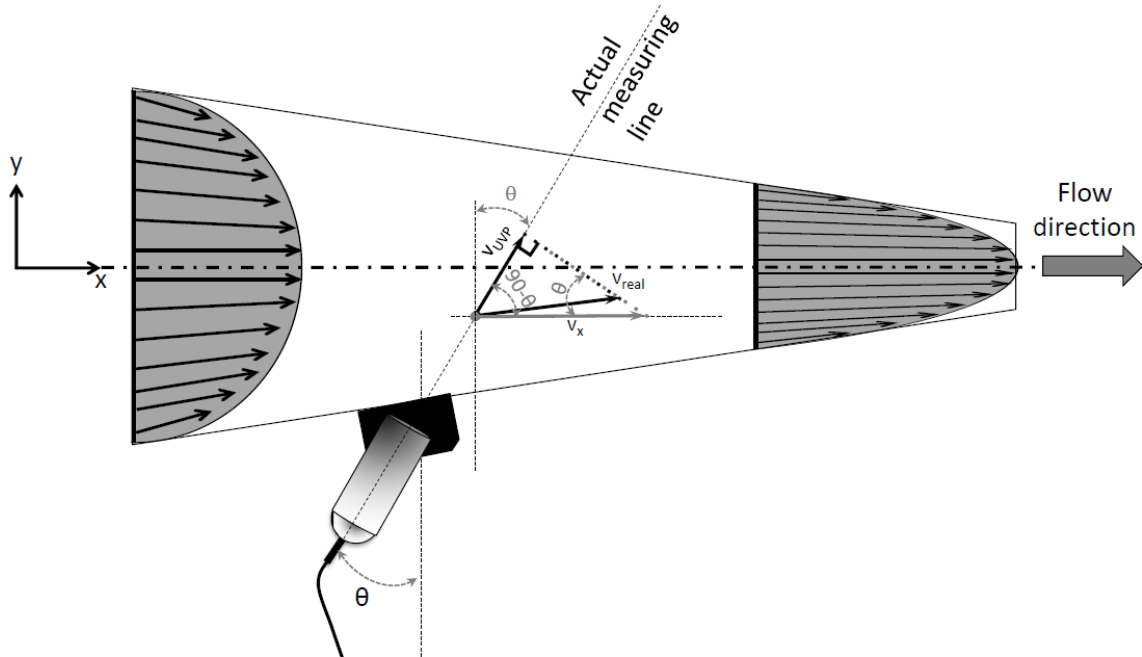

Figure 3: Schematic representation of the possible error in the prediction of velocity components using a standard single transducer UVP technique in contraction geometry with a non-parallel flow stream.

Therefore, a larger velocity value along the flow direction can be estimated in the first half of the contraction tube from the transducer, and the opposite effect can be observed in the second half of the tube. An asymmetric velocity profile can appear in symmetrically collapsed tube flow or a contraction tube; therefore, the single transducer UVP approach will not be applicable for non-parallel flow streamlines. Many works have been done on the flow mapping for the complex flow (Takeda 1987, Ouriev and Windhab 2002, Takeda and Kikura 2002, Takahisa, Yuji et al. 2015, Franke, Rübiger et al. 2016, Hitomi, Murai et al. 2017). The idea is the implementation of two (or more) transducers to obtain the velocity components of the real velocity vector along the measurement line, and the real vector component can be estimated using these vectors as shown in Fig. 4. The conventional or general flow mapping technique or arrangement using UVP is suitable for the parallel flow of respect to the wall.

2.2. The present approach of UVP for collapsed or squeezed tube

The general flow mapping measures velocity components along the measuring lines, which then correlates the obtained information to the real vector as described above (Fig. 4). The present approach is to represent the real velocity vector by splitting into its two components perpendicular to each other, where the two measuring lines of UVP should be perpendicular to each other. The measured vector components result in the two components of the real vector as shown in Fig. 4. Therefore, the real vector magnitude can be calculated accurately by the following equation (2):

$$v_{real} = \sqrt{v_{UVP1}^2 + v_{UVP2}^2} \quad (2)$$

where v_{real} is the real velocity vector, and v_{UVP1} and v_{UVP2} are the vector components along two measuring lines and perpendicular to each other respectively. In the present approach, a new coordinate system is formed by the two perpendicular measuring axes, where the signs of v_{UVP1} and v_{UVP2} are different depending on the direction of the real vectors (as shown in Fig. 4). When the real vector is laid in a specific coordinate, then the corresponding split components will have the sign as mentioned in Fig. 4. The calculation procedure for the real velocity vector in one coordinate (as in Fig. 4) is described below.

In Fig. 4, the angle can be expressed by the following equations (3) and (4):

$$\alpha = \tan^{-1} \left(\frac{|v_{UVP2}|}{|v_{UVP1}|} \right) \quad (3)$$

$$\beta = \pi/2 - \alpha - \theta \quad (4)$$

where α is the angle between v_{UVP1} and v_{real} , and β is the angle between v_{real} and vector component of the real velocity vector along the x-axis (v_x). Then, the sum of θ and α gives the direction of the real velocity vector component from the vertical axis, and the magnitude of a velocity component of the real velocity vector in the x-axis, v_x can be expressed by equation (5):

$$v_x = v_{real} \cos \beta \quad (5)$$

All the collective information mentioned above at a given point will result in a full set of information of the velocity vector with its direction relative to the vertical or horizontal axis at that point.

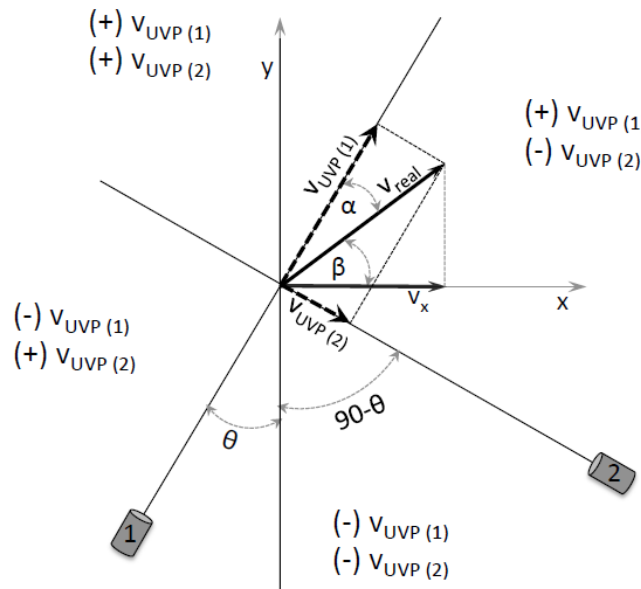

Figure 4: Schematic representation of the present (mathematical) approach to identify the non-parallel velocity vector (v_{real}) by the UVP method (where θ is less than the critical angle).

The velocity profiles can be estimated precisely for any complex geometry using multiple transducers (Fig. 5) for a non-parallel flow situation. Moreover, the experiment on flow mapping of liquid flow in a complex geometry by UVP-method using multiple transducers has been also represented (Takeda and Kikura 2002). In the case of a steady flow situation, two transducers in the UVP method can be used at different points of a target measurement line successively. The proposed 2D measurement technique will provide the opportunity to estimate the velocity profile more accurately resulting in a more accurate estimation of the other relevant parameters such as shear rate profile.

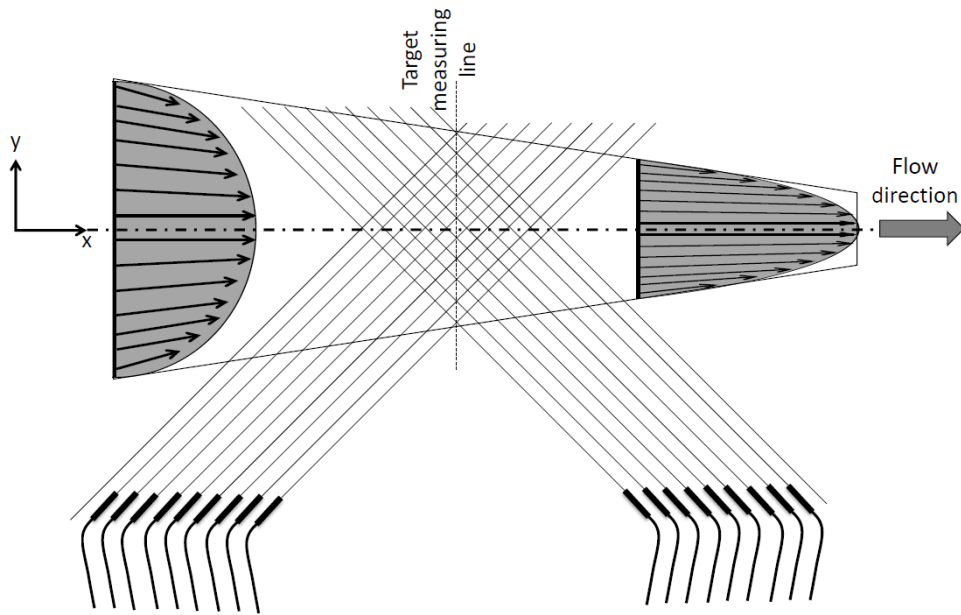

Figure 5: Flow mapping using multiple transducers in the present experimental approach for monitoring parallel or non-parallel velocity vector (v_{real}) in contraction geometry.

2.3. Wall diffraction correction

The ultrasonic wave reflects and diffracts from the tube wall (Messer and Aidun 2009) during UVP measurement. The wave diffracts and shifts horizontally (depending on the wall thickness) due to the diffraction of ultrasound through the wall during the second diffraction happening from the fluid flowing through the tube, and continues to follow a line parallel to the incident wave line. The possible corrections due to the wall diffraction on the intersect-point of two measuring lines are described in the appendix (Nahar 2012). In the present study, the error is insignificant due to a very small value of d and d/D (where d and D are the thickness of the wall, and diameter of the tube respectively).

3. Experiment and result-discussion

The contraction and expansion flow in elastic tubes are encountered in various physiological flows. To understand the physiological flow, *in-vitro* analysis on the contraction and expansion flow behavior is vital. In the present study, we have tried to study a contraction flow in an elastic tube and make an accurate prediction of the flow profile using the UVP technique. The study will be helpful to estimate the rheological parameters precisely of non-Newtonian flow involved in the physiological flow situation.

3.1. Materials and methods

The present study is carried out in a circular elastic tube with a gradual vertical collapse at the end (Fig. 6). In Fig. 6 (left), top and front views of the experimental setup are represented, where flow direction from left to right is maintained. An aqueous solution of 1.5 % carboxymethyl-cellulose (CMC; Blanose CMC 7MF, IMCD Switzerland AG) was used at a steady flow rate of 144 ml/min. The aqueous solution also contains 0.3 % polyamide particle for better UVP resolution. Due to a small amount of polyamide, the solution viscosity was found to be unchanged (Nahar, Jeelani et al. 2012b). At a flow rate of 144 ml/min, the average wall shear rate ($\dot{\gamma}_{wall} = \frac{32Q}{\pi D^3}$, where $\dot{\gamma}_{wall}$; Q ; D^3 are wall shear rate, fluid flow rate, and equivalent diameter at the target measuring line respectively) in the tube was found in the zero-shear viscosity region (shear rate of about 60 s^{-1} or higher) of CMC (Nahar, Jeelani et al. 2012b). To avoid any expansion of the elastic tube (diameter: 2 cm; and wall thickness: 0.1 cm), lower fluid flow was maintained in the present study. The sound velocities (at $22 \text{ }^\circ\text{C}$) through the 1.5 % CMC solution (including 0.3 % polyamide) and the elastic tube wall were found to be 1499 m/s and 992 m/s respectively. Since the elastic tube wall thickness (d) is very small (1 mm) compared to the tube inner diameter (approx. $d/D = 0.05$, where d is the tube wall thickness and D is the inner tube diameter), the ultrasound diffraction effect at the wall is considered to be insignificant, however, the ultrasound wall diffraction effect has been considered in the present calculation (as described in the appendix).

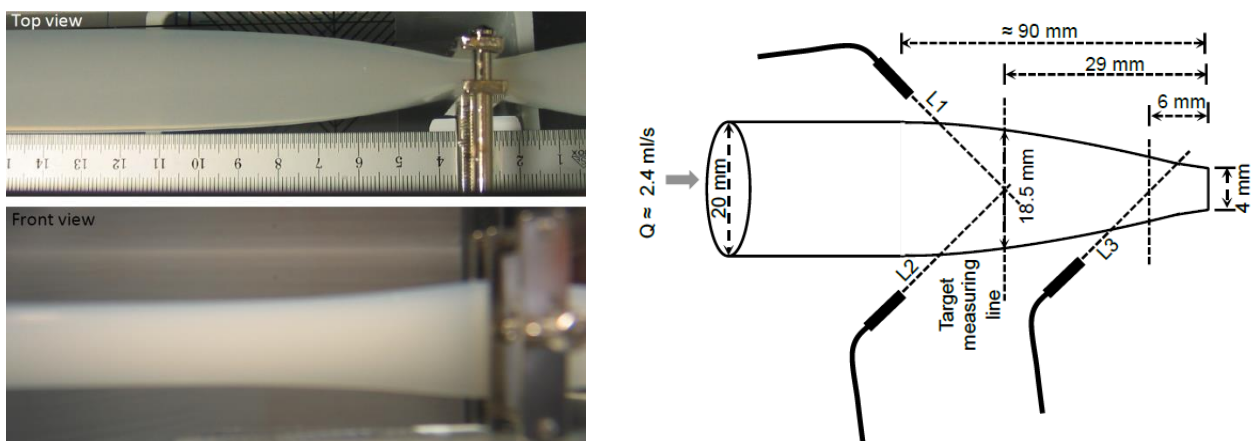

Figure 6: (LHS) Image and (RHS) schematic representation of experimental set up with tube dimensions and measuring lines.

A standard UVP profiling methodology was used as described in (Met-Flow 2002,

Birkhofer 2007, Nahar 2012) using a UVP-Duo (Met-Flow SA, Switzerland) instrument. A MATLAB (MathWorks, USA) based application with a Graphical User Interface (GUI) was developed by (Birkhofer 2007) (where the communication with the UVP-Duo is made with an ActiveX Library from Met-Flow SA) and has been adopted and used in the experiment.

An ultrasound transducer of 8 MHz emission frequency with 2 mm active diameter and 5 mm housing diameter was used. To observe the impact of the standard UVP measurement in a contraction flow, two different target measuring lines were selected (i) at 2.9 cm (nearly circular tube) and (ii) at 0.6 cm (oval tube) away from the squeezed section as shown in Fig. 6 (RHS). Varying the positions of UVP transducers, two opposite directional measuring lines were selected so that their intersect point lays in the target measuring line (as shown in Fig. 5 and Fig. 6-RHS). The transducers were shifted gradually in the predetermined position so that the crossing point always stays in the target measuring line (length of the target measuring line at 2.9 cm away from the squeezed section was 1.85 cm, and the length of the target measurement line at 0.6 cm away from the squeezed section was 1.0 cm). At 2.9 cm away from the squeezed section, the crossing points were adjusted at the target measuring line in every 3.0 mm. To observe the real velocity vector, six crossing-points were examined along the target measuring-line. At 0.6 cm away from the squeezed section, the velocity profiles were only monitored at the same flow rate to show the effect of contraction and possible error on the velocity profile.

3.2. Velocity profile and flow mapping

The velocity profiles in the circular elastic tube (approximately 9 cm apart from squeezed section) have been investigated at a flow rate of 144 ml/min using a single line UVP technique as shown in Fig. 7 (LHS). At the same flow rate, the velocity profile has been measured close to the squeezed section (0.6 cm apart from the squeezed section as in Fig. 6-LHS) of the elastic tube as in Figure 7 (RHS). In Fig. 7 (LHS), it is visible that the measured velocity profile is symmetric-parabolic since the flow seems to be fully developed and parallel to the tube wall at a low flow rate regime (Reynolds Number: 1.0) for weak shear-thinning fluid (Zero-shear viscosity: 0.143 Pa.s). Whereas, the flow profile close to the squeezed section is found to be non-symmetric as in Fig. 7 (RHS).

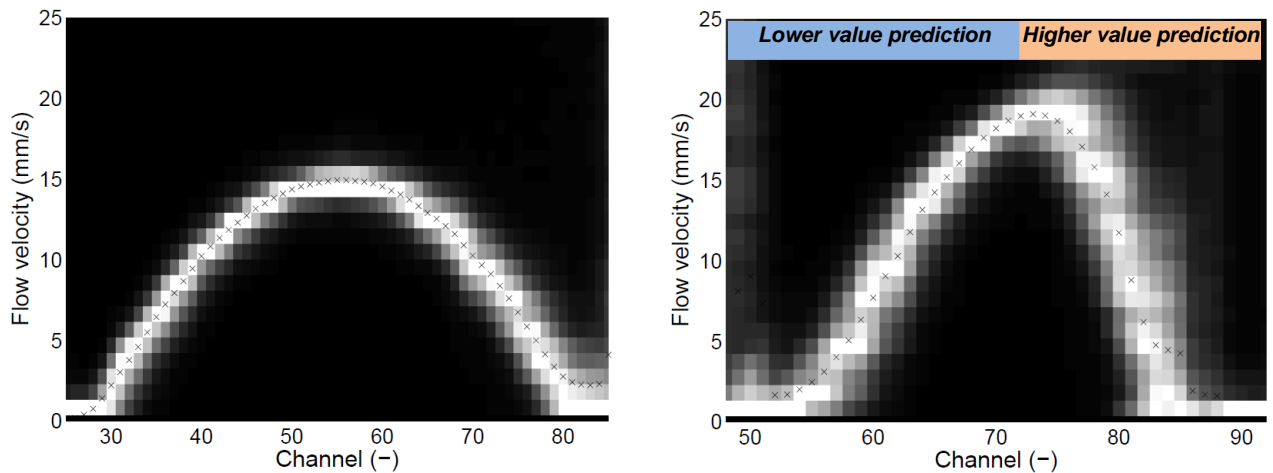

Figure 7: Measured velocity profile in a circular tube (LHS) and a squeezed elastic tube (RHS) by UVP method along the measuring line, L3, (shown in Fig. 6, RHS). [Spatial resolution: 0.37 mm].

As stated earlier (with the support of Figs. 2 & 3) that the inapplicability of the single transducer UVP technique for the contraction flow can result in non-symmetric profile due to lower (close to the transducer) or higher (apart from the transducer) velocity component in the flow direction. Hence, the first half of the velocity profile is under predicted, whereas the second half is over predicted. Therefore, any further utilization of the data (e.g. shear-rate calculation) can lead to a significant inaccuracy. To minimize the error for complex flow geometry, a new measurement approach using multiple transducer-based UVP profiling has been implemented as described earlier and represented in Fig. 4.

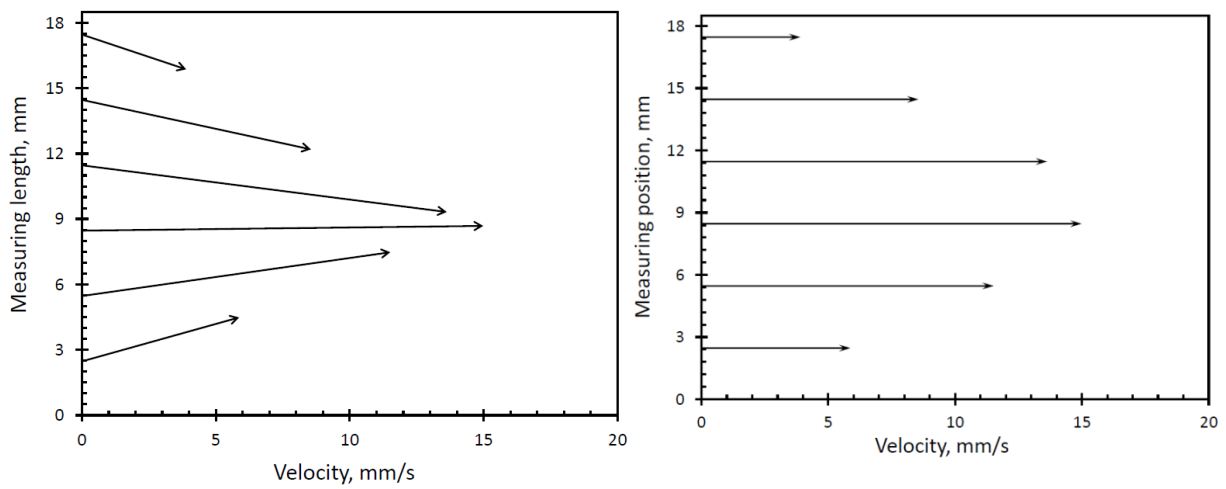

Figure 8: (LHS) The real velocity vectors (v_{real}) and (RHS) the axial velocity component (v_x) in the squeezed elastic tube are obtained by UVP using the present approach (Fig. 4).

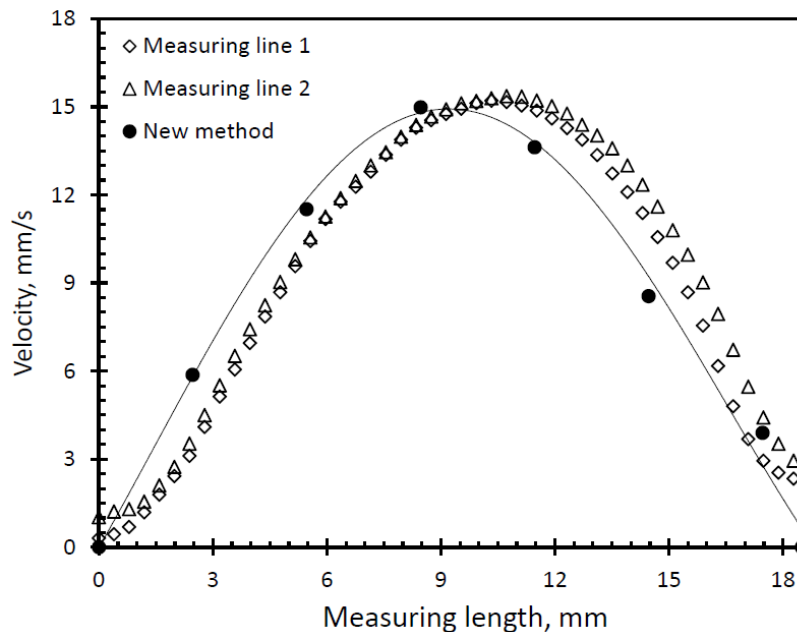

Figure 9: Single transducer-based UVP profile in a squeezed elastic tube along two measuring lines ($L1$ and $L2$) as in Fig. 6, and the velocity profile constructed from the measured velocity component (v_x) in the flow direction based on the present approach.

Another set of experiments has been performed applying the present approach (as discussed earlier and represented in Figs. 4 & 5) at 2.9 cm apart from the squeezed section, and the transducer set-up is shown in Fig. 6 (RHS). In the new measuring approach, two transducers were implemented to acquire the accurate velocity vectors in the target measuring line (2.9 cm away from the squeezed area) with a length of 1.85 cm and 6 measurement points (0.3 cm apart from each other) those (by two transducers) intersect at the target measurement line (Fig. 5). The results show the actual velocity vectors along the measuring line in Fig. 8 (LHS), which are clearly non-parallel to the wall and each other. The corresponding velocity components (v_x) of the actual velocity vectors in the flow direction (x -axis) are estimated and represented in Fig. 8 (RHS). From Fig. 8 (RHS), it is recognizable that the obtained velocity profile using the present approach is symmetric and nearly parabolic (not fully parabolic due to contraction or extensional flow). The velocity profile using the present approach is also plotted in Fig. 9 along with two single transducer measurements (opposite direction as shown in Fig. 6-RHS), those meet in the middle of the target measuring line. Again, it is clearly visible that the single transducer profile is asymmetric and the profile using the proposed approach is symmetric. It is also seen that the single transducer profile is under predicted in the first-half and over-estimated in the second half compared to the symmetric profile obtained by the new measurement approach. The velocity profile using the proposed technique is not only symmetric but also the maximum velocity is obtained at the tube center. On the other hand, the standard single line UVP method shows a non-symmetric velocity profile and the velocity prediction at the first-half and second-half region of the tube from the transducer is smaller and larger respectively compared to that of the real velocity profile. Therefore, the new approach is reasonably suitable for complex flow geometries compared to the conventional measurement technique that has been tried elsewhere (Kotzé and Wiklund 2014, Nahar, Dubey et al. 2019).

4. Conclusions

The ultrasonic Doppler velocimetry (UVP) method is well known for the laminar flow stream in a circular tube; however, not very suitable for complex flow situations. In the present study, an improved experimental approach of the UVP using multiple transducers has been demonstrated. The new approach represents the velocity profile to be more accurate for non-parallel flow situations such as contraction flow. An experimental investigation has been performed to predict the velocity profile accurately in a squeezed elastic tube (contraction flow). The experimental approach has been used with two sets of transducers in perpendicular to each other to obtain the magnitude of the real velocity vector (v_{real}), the direction of velocity-vector, and the velocity component (v_x) of the real velocity-vector in the flow direction. The study shows that the velocity profile can be estimated more accurately using the present approach and symmetric profile can be also obtained for a contraction flow through an elastic tube compared to single transducer based standard UVP technique. Therefore, the prediction of any further information from a velocity profile such as shear-rate can be more

accurately estimated using the present approach.

Acknowledgments

The authors are thankful to the Swiss National Science Foundation (SNF Project 200020-132850/1) and the German Research Foundation (Project number 123555429) for financial support.

Appendix

In Fig. 10, it is seen that the actual measuring point can be different than the target measuring point in the measuring target measuring line. Therefore, a geometric solution is presenting here, that easily implemented by knowing the Doppler angle, the thickness of the wall, the velocity of sound in solution and wall. When $v_{sound(solution)} \geq v_{sound(wall)}$, the target measurement point is shifted by Δy in the vertical direction (shown in Fig. 10), which can be estimated by the following procedure.

$$\tan \alpha = \frac{x_1}{d} \quad (6)$$

$$\tan \theta = \frac{x_1 + \Delta x}{d} \quad (7)$$

From equations (6) and (7), Δx can be expressed by the following equation.

$$\Delta x = d(\tan \theta - \tan \alpha) \quad (8)$$

From Snell's law (equation 9),

$$\frac{\sin \theta}{\sin \alpha} = \frac{v_{sound(solution)}}{v_{sound(wall)}} \quad (9)$$

Therefore,

$$\alpha = \sin^{-1} \frac{v_{sound(wall)}}{v_{sound(solution)}} \sin \theta \quad (10)$$

Δy can be expressed by the following equation.

$$\Delta y = \frac{\Delta x}{\tan \theta} \quad (11)$$

From equations (8), (10) and (11), Δy can be calculated by knowing the incident angle θ , tube wall thickness (d), and the sound velocity in the solution and tube wall. θ will be different for contraction type of geometry, which can be corrected by $\theta_{new} = \theta + \theta'$, where θ' is the inclined slope of the wall with respect to the horizontal axis.

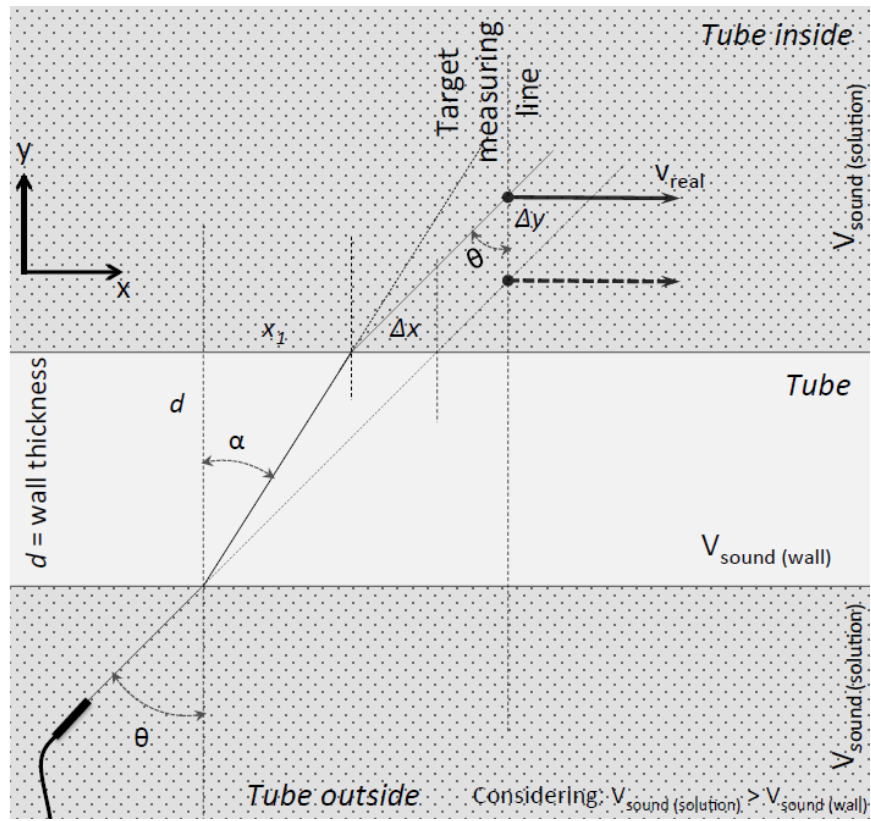

Figure 10: Schematic presentation of the necessity of the wall correction due to diffraction of ultrasound.

References

- Ala, A. A., S. Tan, A. Eltayeb and Z. Abbati (2019). "Experimental study on sudden contraction and split into the inlets of two parallel rectangular jets." Experimental Thermal and Fluid Science **104**: 272-283.
- Alokaily, S., K. Feigl and F. X. Tanner (2019). "Characterization of peristaltic flow during the mixing process in a model human stomach." Physics of Fluids **31**(10): 103105.
- Bashir, A. I., M. Everts and J. P. Meyer (2019). "Influence of inlet contraction ratios on the heat transfer and pressure drop characteristics of single-phase flow in smooth circular tubes in the transitional flow regime." Experimental Thermal and Fluid Science **109**: 109892.
- Berta, M., J. Wiklund, R. Kotzé and M. Stading (2016). "Correlation between in-line measurements of tomato ketchup shear viscosity and extensional viscosity." Journal of Food Engineering **173**: 8-14.
- Birkhofer, B. (2011). Practical Food Rheology: An Interpretive Approach, chapter Doppler Ultrasound-Based Rheology, Wiley-Blackwell.
- Birkhofer, B. H. (2007). Ultrasonic in-line characterization of suspensions. PhD PhD, ETH Zurich.
- Birkhofer, B. H., S. A. K. Jeelani, E. J. Windhab, B. Ouriev, K.-J. Lisner, P. Braun and Y. Zeng (2008). "Monitoring of fat crystallization process using UVP-PD technique." Flow Measurement and Instrumentation **19**(3): 163-169.
- Choi, Y. J., K. L. McCarthy and M. J. McCarthy (2002). "Tomographic Techniques for Measuring Fluid Flow Properties." Journal of Food Science **67**(7): 2718-2724.
- Dong, F., H. Gao, W. Liu and C. Tan (2019). "Horizontal oil-water two-phase dispersed flow velocity profile study by ultrasonic Doppler method." Experimental Thermal and Fluid Science **102**: 357-367.
- Franke, S., D. Rübiger, V. Galindo, Y. Zhang and S. Eckert (2016). "Investigations of electrically driven liquid metal flows using an ultrasound Doppler flow mapping system." Flow Measurement and Instrumentation **48**: 64-73.
- Haya, L. and S. Tavoularis (2017). "Comparison of in vitro flows past a mechanical heart valve in anatomical and axisymmetric aorta models." Experiments in Fluids **58**(6): 73.
- Hitomi, J., Y. Murai, H. J. Park and Y. Tasaka (2017). "Ultrasound Flow-Monitoring and Flow-Metering of Air–Oil–Water Three-Layer Pipe Flows." IEEE Access **5**: 15021-15029.
- Hughes, P. E. and T. V. How (1993). "Quantitative measurement of wall shear rate by pulsed Doppler ultrasound." Journal of Medical Engineering & Technology **17**(2): 58-64.
- Islam, M. A., B. Ehiraj, C. K. Cheng, B. N. Dubey and M. M. R. Khan (2019). "Biofilm re-vitalization using hydrodynamic shear stress for stable power generation in microbial fuel cell." Journal of Electroanalytical Chemistry **844**: 14-22.
- Kotzé, R., R. Haldenwang, V. Fester and W. Rössle (2015). "In-line rheological characterisation of wastewater sludges using non-invasive ultrasound sensor technology." Water SA **41**: 683-690.
- Kotzé, R. and J. Wiklund (2014). "Ultrasound Doppler measurements inside a diaphragm valve using novel transducer technologies." Measurement Science and Technology **25**(10): 105302.
- Kotzé, R., J. Wiklund, R. Haldenwang and V. Fester (2011). "Measurement and analysis of flow behaviour in complex geometries using the Ultrasonic Velocity

- Profiling (UVP) technique." Flow Measurement and Instrumentation **22**(2): 110-119.
- Kozlovsky, P., U. Zaretsky, A. J. Jaffa and D. Elad (2014). "General tube law for collapsible thin and thick-wall tubes." Journal of Biomechanics **47**(10): 2378-2384.
- Liu, P., H. Zhang, Y. Wu, M. Zhang and J. Lu (2017). "Experimental study on the flow interaction of two parallel rectangular jets through exits with sudden contraction." Experimental Thermal and Fluid Science **88**: 622-631.
- Lu, J., M. Ferri, S. Ubal, O. Campanella and C. M. Corvalan (2019). "Contraction of a shear-thinning axisymmetric cavity." Physics of Fluids **31**(12): 123103.
- Messer, M. and C. K. Aidun (2009). "Main effects on the accuracy of Pulsed-Ultrasound-Doppler-Velocimetry in the presence of rigid impermeable walls." Flow Measurement and Instrumentation **20**(2): 85-94.
- Met-Flow, S. (2002). UVP Monitor Model UVP-DUO With Software Version 3.
- Nahar, S. (2012). Steady and unsteady flow characteristics of non-Newtonian fluids in deformed elastic tubes. PhD, ETH Zurich.
- Nahar, S., B. N. Dubey and E. J. Windhab (2019). "Influence of flowing fluid property through an elastic tube on various deformations along the tube length." Physics of Fluids **31**(10): 101905.
- Nahar, S., S. A. Jeelani and E. J. Windhab (2012b). "Peristaltic flow characterization of a shear thinning fluid through an elastic tube by UVP." Applied Rheology **22**(4): 43941.
- Nahar, S., S. A. K. Jeelani and E. J. Windhab (2012a). "Influence of elastic tube deformation on flow behavior of a shear thinning fluid." Chemical Engineering Science **75**: 445-455.
- Nahar, S., S. A. K. Jeelani and E. J. Windhab (2013). "Prediction of velocity profiles of shear thinning fluids flowing in elastic tubes." Chemical Engineering Communications **200**(6): 820-835.
- Ouriiev, B. and E. J. Windhab (2002). "Rheological study of concentrated suspensions in pressure-driven shear flow using a novel in-line ultrasound Doppler method." Experiments in Fluids **32**(2): 204-211.
- Takahisa, S., T. Yuji, O. Yoshihiko and M. Yuichi (2015). "Ultrasonic velocity profiling rheometry based on a widened circular Couette flow." Measurement Science and Technology **26**(8): 085302.
- Takeda, Y. (1986). "Velocity profile measurement by ultrasound Doppler shift method." International Journal of Heat and Fluid Flow **7**(4): 313-318.
- Takeda, Y. (1987). "Measurement of Velocity Profile of Mercury Flow by Ultrasound Doppler Shift Method." Nuclear Technology **79**(1): 120-124.
- Takeda, Y. and H. Kikura (2002). "Flow mapping of the mercury flow." Experiments in Fluids **32**(2): 161-169.
- Tanner, F. X., A. A. Al-Habahbeh, K. A. Feigl, S. Nahar, S. A. K. Jeelani, W. R. Case and E. J. Windhab (2012). "Numerical and experimental investigation of a non-newtonian flow in a collapsed elastic tube." Applied Rheology **22**(6): 639101-639108.
- Tasaka, Y., B. Birkhofer, N. Furuichi, H. Kikura, H. Minagawa, Y. Murai, H. Murakawa, M. Motozawa, S. Nahar, H. Obayashi, T. Sawada, A. K. J. Shaik, Y. Takeda, K. Tezuka, Y. Tsuji, T. Yanagisawa, S. Wada, J. Wiklund and E. J. Windhab (2012). Practical applications. Fluid Mechanics and its Applications. **101**: 107-200.

- Tiwari, N., Y. Tasaka and Y. Murai (2019). "Pressure field estimation from ultrasound Doppler velocity profiler for vortex-shedding flows." Flow Measurement and Instrumentation **67**: 23-32.
- Wada, S., K. Tezuka, W. Treenuson, N. Tsuzuki and H. Kikura (2013). "Estimating the number of transducers for flow rate measurement using the UVP method downstream of double elbows." Flow Measurement and Instrumentation **32**: 51-62.
- Wang, H., S. Lee and Y. A. Hassan (2016). "Particle image velocimetry measurements of the flow in the converging region of two parallel jets." Nuclear Engineering and Design **306**: 89-97.
- Wiklund, J., I. Shahram and M. Stading (2007). "Methodology for in-line rheology by ultrasound Doppler velocity profiling and pressure difference techniques." Chemical Engineering Science **62**(16): 4277-4293.
- Wiklund, J. A., M. Stading, A. J. Pettersson and A. Rasmuson (2006). "A comparative study of UVP and LDA techniques for pulp suspensions in pipe flow." AIChE Journal **52**(2): 484-495.
- Windhab, E. J. (2014). "Potential of Ultrasound-Doppler in process flow measurements along the food value chain " Proceeding of ISUD9: 137-144.
- Yoshida, T., Y. Tasaka and Y. Murai (2017). "Rheological evaluation of complex fluids using ultrasonic spinning rheometry in an open container." Journal of Rheology **61**(3): 537-549.