

Can 6LoPLC Enable Indoor IoT ?

IKPEHAI, Augustine, ADEBISI, Bamidele and ANOH, Kelvin

Available from Sheffield Hallam University Research Archive (SHURA) at:

<http://shura.shu.ac.uk/24594/>

This document is the author deposited version. You are advised to consult the publisher's version if you wish to cite from it.

Published version

IKPEHAI, Augustine, ADEBISI, Bamidele and ANOH, Kelvin (2019). Can 6LoPLC Enable Indoor IoT ? In: 2019 IEEE International Symposium on Power Line Communications and its Applications (ISPLC). IEEE.

Copyright and re-use policy

See <http://shura.shu.ac.uk/information.html>

Can 6LoPLC Enable Indoor IoT ?

Augustine Ikpehai^{*}, Bamidele Adebisi[‡] and Kelvin Anoh[‡]

^{*}Department of Engineering & Mathematics, Sheffield Hallam University, SW1 1WB, Sheffield, UK

[‡]School of Engineering, Manchester Metropolitan University, M1 5GD, Manchester, UK.

a.ikpehai@shu.ac.uk; {b.adebisi, k.anoh}@mmu.ac.uk

Abstract—Energy conservation and network longevity are key requirements of Internet of things (IoT) applications. However, these can be challenging in indoor environments such as dwellings with reinforced concrete walls and high-bay areas using battery-powered wireless devices. This paper presents a low-power power line communication over IPv6 network (6LoPLC) for in-building IoT applications. 6LoPLC adopts a PLC physical layer (PHY) and exploits media access control (MAC) features of IEEE 802.15.4 devices as well as 6LoWPAN to deliver low-power, low rate PLC. One of the unique advantages of 6LoPLC is that the nodes are mains-connected which eliminates the network disruption caused by battery depletion in wireless nodes. Furthermore, 6LoPLC saves the time and effort on battery recharge or replacement, simplifies network management and reduces wiring cost. The results reveal that the proposed system can yield about 5.05 dB reduction in energy requirement relative to HomePlug Green PHY without violating the delay tolerance of the IoT applications. It is further shown that using the 6LoPLC technique, delays of about 48 ms and 129 ms are feasible in residential and commercial buildings respectively.

Index Terms—6LoPLC, building area network (BAN), smart city, smart home, Internet of things (IoT), power line communication (PLC).

I. INTRODUCTION

Internet of things (IoT) has witnessed exponential growth in many sectors in the last two decades, including manufacturing health, energy, agriculture, buildings, etc. Towards digital citizenship, IoT has recently been extended to commercial and residential buildings. The important requirements of IoT services include low cost of deployment, low energy consumption, extended device life of 20 years or more [1], [2] [3] and uninterrupted operation. In most cases, the device life is determined by the battery and a node becomes inactive once its battery is exhausted. Given the current growth trajectory of IoT, an emerging concern is how the several billions of sensors and end devices will be powered and maintained in the medium to long term.

Indoor IoT can be supported by a range of low-power technologies. While these technologies support certain degree of flexibility, they are typically battery-powered and often require replacement when their batteries are fully depleted. This can be ineffective in hard-to-reach areas in buildings such as basements and high-bay areas in warehouses, gymnasiums and high-risk areas where frequent visits are not advised.

Since many IoT applications are not strictly real time (e.g. meter reading, temperature monitoring, etc), it is common to find low bit rate, wireless systems such as ZigBee and Bluetooth in indoor IoT deployments. IEEE However, wireless communication is known to be sub-optimal in

environments with reinforced concrete walls or floors including basements and elevators (Faraday cage). Thus, the low-rate wireless technologies experience blind spots in the network. While this may be overcome by deploying wireless fidelity (Wi-Fi) which uses higher transmit power or power over Ethernet (PoE) where installation of new dedicated cables are prohibited or costly, both of these approaches are counter-productive in terms of energy consumption.

In buildings, no other technology guarantees the ubiquity offered by power line communication (PLC). Furthermore, the use of existing power cables for communication drastically reduces the wiring cost, bill of material as well as simplifies the network management. Given that the transceivers are mains-connected, PLC also ensures continuous access to power supply throughout the network life. This eliminates network disruptions that arise when the batteries in wireless sensors are depleted and disconnect the node from the network. In many countries, buildings already account for more than one-third of energy consumption [4]. Thus, the ongoing deployment of IoT application will introduce additional energy demands in buildings. As the IoT landscape continues to evolve over the coming years, low-power PLC will uncover new possibilities to innovate new disruptive access technologies for the teeming IoT applications.

In this paper, we employ the Hanadu physical layer (PHY) specification of low-power PLC and adopt some MAC features of the IEEE 802.15.4 specification for low-rate wireless personal area networks (LR-WPANs). IPv6 over low-power wireless personal area networks (6LoWPANs) are characterised by low throughput. In order to conserve energy when transmitting data over the IP network, an adaptation layer is introduced in the PLC system. The main contribution of this paper is two-fold. First, we exploit the use of 6LoWPAN in power lines to constrain the MTU size to 127 bytes without violating the delay requirements of the IoT applications. Secondly, we use conventional broadband PLC spectrum (0-30 MHz) to provide low-data rate connectivity for indoor IoT devices. Both of these reduce the energy requirements of the communication system. The rest of this paper is organised as follows. Previous related work on low-power communication for indoor IoT is presented in Section II while Section III describes the communication network model and test bed employed in this work. The Hanadu evaluation kits are described in Section IV, with a highlight of the modifications made. In Section V, we discuss the results and the main conclusions are highlighted in Section VI.

II. LOW-POWER COMMUNICATION FOR INDOOR IOT: RELATED WORK

The promise of IoT is to interconnect anyone, any device at any time and any where. Thus, a considerable amount of development efforts have been made at developing low-power communication systems by various bodies and interest groups. These have culminated in the release of LP-WANs [2], Bluetooth, ANT, ANT+, ZigBee, ZigBee-RF4CE, Nike+, Infrared Data Association (IrDA), NFC, Z-Wave, etc [5]. Beyond the capability to monitor and control building assets, the enabling IoT network is also expected to facilitate energy savings. Previous studies such as [6] indicate that smart control systems in buildings can yield up to 40% energy saving for lighting application. However, the study did not consider the energy consumed by the underlying communication systems. Without appropriate optimisation or deployment of low-power technologies, this saving can be undermined by the energy consumed by the enabling communication technology. Although low power wireless systems are widely deployed in buildings, many of them share the license-free spectrum with other radio services. The effect is that the building area network (BAN) connectivity is prone to interference which results in unnecessary energy consumption and is more impactful in constrained devices such as wireless sensors.

Low-rate, low-power PLC has so far received less attention than other aspects of PLC such as channel modelling, impulsive noise and interference cancellation, spectral analysis as well as electromagnetic compatibility. In fact, until the recent publication of IoTPLC (IEEE 1901.3) standard, the closest low-power PLC specification was the HomePlug Green PHY. Study in [7] reported that energy consumption of PLC transceiver consists of static and dynamic components. While the former is fixed and used to power the electronic circuitry of the transceiver, the latter is dependent on the traffic load. Experiments involving different PLC devices concluded that although static energy dominates the consumption, dynamic energy can sometimes be up to 50% [8]. It was further observed during the measurements that data reception typically consumes less energy than transmission by 20%-25%. These studies point to the fact that energy consumption of the PLC transceivers can be improved in a variety of ways including optimised transceiver design and advanced signal processing. In view of these, reduced data rate and message length can be exploited to improve energy consumption.

Low-power PLC is even more attractive in most indoor IoT applications given that they are not real-time and are characterised by short message lengths as well as periodic transmissions at low data rates. Since many backhaul technologies are readily available to deliver reliable, low latency connectivity to the Internet, the potential bottleneck resides within the BAN. As PLC continues to gain acceptance for IoT applications, some studies have been conducted to ascertain use-cases for PLC in IoT networks. In this regard, various PLC-wireless hybrids have also been proposed. For example, [6] implemented a wireless sensor network (WSN) aided by PLC to improve packet delivery and coverage while [9] demonstrated LoRa-PLC for IoT applications. The main commonality in these studies is that PLC was used to improve network coverage, energy optimisation was

not part of their objectives. Consequently, network range and reliability were achieved at the expense of energy consumption in the systems.

III. COMMUNICATION NETWORK MODEL AND TEST BED

A. Model

In smart city end devices, energy consumption is affected by transmission duration, throughput and payload size. Although multi-year battery life is a major performance target, the battery capacity usually depends on the requirements of the specific use-case. The field condition can be worsened by obstruction losses which will further reduce the link budget. Fig. 1 illustrates the IoT-based data acquisition model employed in this study, based on indoor power line topology.

B. The Hanadu-based 6LoPLC System

The HomePlug green PHY is known to consume less energy than other PLC specifications such as HomePlug AV. Nevertheless, with data rate of 10Mbps using 1155 subcarriers, HomePlug green PHY is not optimised for most IoT applications which require lower data rates. Hanadu is a low-power modulation technique for PLC developed by Xsilon (patent granted), an industrial partner in the recently concluded innovate-UK funded *Smart In-Building Micro Grid for Energy Management* project [4]. It defines the PHY functionalities for low rate transmission over power lines and employs OFDM with differential binary phase shift keying (DBPSK). The protocol stack employed in the evaluation kits is illustrated in Fig. 2.

PLC networks share some PHY characteristics such as orthogonal frequency division multiplexing (OFDM) with LR-WPANs as defined in the IEEE 802.15.4 standard. Hence, some MAC layer features of LR-WPAN including CSMA-CA and TDMA access schemes can be exploited in power line domain. The use of IPv6 at network layer not only provides interoperability with standard communication infrastructure but also ensures future-readiness of the system. 6LoWPAN was developed with these in mind and is adopted at the adaptation layer (as *6LoPLC*) in this study. The main role of adaptation layer is to constrain the MTU from 1280 bytes in full IPv6 packet to 127 bytes. The constrained application protocol (CoAP) is a UDP-based light-weight web transfer protocol standardised by Internet Engineering Task Force (IETF) for low-power, low-rate networks such as machine-to-machine (M2M) and IoT in RFC7252. In this study, CoAP provides the web interface for the request/response data exchange between the IoT end points and the gateway.

With this, the sensor and LED-lamp operate as IPv6-capable nodes which can be respectively monitored and controlled over the low-power PLC network. The Hanadu gateway is the PLC equivalent of the PAN coordinator in LoWPANs in that it coordinates the network. Its functions includes assignment of IPv6 address to nodes and connection to IoT cloud through the wide area network (WAN). In order to monitor the network, the gateway and end nodes exchange Internet control message protocol version 6 (ICMPv6) requests and replies periodically as keep-alive messages.

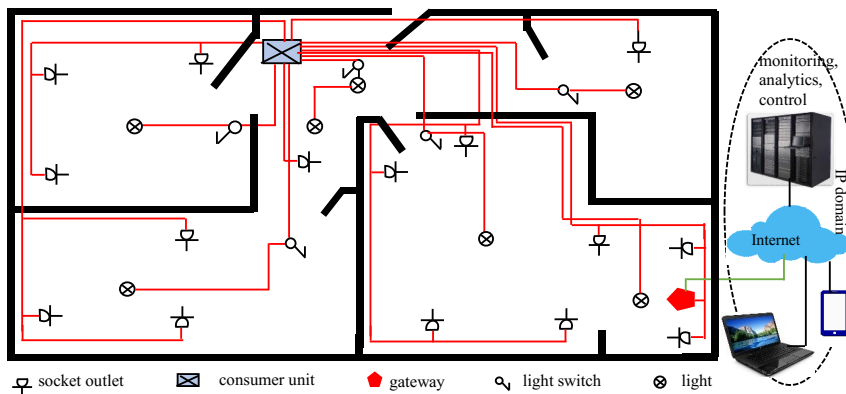

Figure 1: In-home PLC network based on UK power line topology for residential buildings

Application	CoAP
Transport	UDP, ICMPv6
Network	IPv6
	6LoPLC
Data Link	IEEE802.15.4
Physical	Hanadu PLC PHY

Figure 2: Protocol mapping including the Hanadu PHY and 6LoPLC as adaptation layer protocol

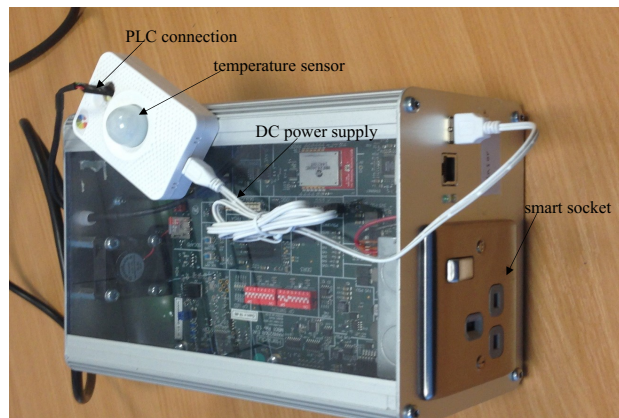

Figure 3: A Hanadu kit with retrofitted sensor and socket

The current Hanadu chips employ a power spectral density (PSD) of $90\mu\text{V}/\text{Hz}$ ($-16.99\text{ dBm}/\text{Hz}$). Although the EN55022 recommends $-50\text{dBm}/\text{Hz}$ which is equivalent to about $60\text{dB } \mu\text{V}/\text{Hz}$ at 100Ω , the more recent EN50561-1 allows up to $95\text{dB}\mu\text{V}$ using transmit power control where the path loss between transmitter and receiver is $\geq 40\text{dB}$, provided the requisite spectral mask is observed. Thus, the current Hanadu kits are based on the latter specification. To ensure co-existence, the broadcast and amateur radio frequencies are notched out in the Hanadu which results in usage of only 86 out of the 128 sub-carriers in the tone map. In addition, the dynamic frequency exclusion as defined in EN50561-1 will apply in subsequent prototypes before commercial release.

Although narrowband PLC can also deliver low data rates to meet indoor IoT requirements, one of the merits of Hanadu is the adoption of IEEE 802.15.4 MAC features as well as the possibility of a seamless integration of LR-WPAN silicon chips with Hanadu in the same module. This will not only improve the coverage but also potentially improve network's resilience to failures.

IV. EVALUATION

One Hanadu gateway and two nodes were available for the evaluation exercise and in order to investigate the system performance for low-rate applications, a 6LoPLC test bed was setup for assessment of end-to-end communication. To investigate larger networks, a representative model was developed in NS-3 based on the parameters obtained from the test bed and validated with measurements as reported

in [4]. In this study, we re-calibrate the model (including the downgrade of PSD to $-50\text{dBm}/\text{Hz}$ and network scale up) in order to tailor it to the low-power requirement of IoT applications. Thereafter, we generate several samples of delay to study application performance using different characteristics.

A. Test bed

The 6LoPLC testbed is made up of three sub-systems: IoT object, communication and application. While the object consists of sensor and LED lamp, two evaluation units of 6LoPLC modem provided the end-to-end communication system to convey signals from PLC gateway to LED and sensor. In terms of application, CoAP client is embedded in the Hanadu gateway while the CoAP server integrated in the end nodes (sensor, lamp). In contrast with filament-based lights, the LED lamp used in this work is a valid IPv6-capable network node deployed as lights whose intensity is controllable over the power line network. The PLC-based sensor is illustrated in Fig. 3.

The role of the CoAP server is not only to provide an interface for extracting the temperature data from the sensor and the energy consumption information of the device connected to the attached socket but also to encode the data as well as receive control signals to alter the brightness of the light (in the case of LED node). The gateway assigns IP addresses to the end devices and coordinates the network topology. The background noise and impulsive noise power were measured and used to evaluate the BER performance of the system.

Table I: Additional Simulation Parameters

Parameter	Value
spectrum	0-32 MHz (2-28 MHz used)
Impedance (fixed)	50 Ω
OFDM sub-carriers	128(86 active)
Symbol duration	4 μ s
Channel spacing	250 Hz
Modulation/coding	DBPSK
Impulsive noise power	9.91 dBm
Noise (measured)	background: -96.52 dBm/Hz
Inter-socket distance	2.5 m
Inter-node distance	5.5 m
MTU	127 bytes
CoAP payloads	sensor:8 bytes, control: 30 bytes

B. Simulation

In NS-3 simulator, we create a model for the 6LoPLC network using similar characteristics as implemented in Hanadu kits and the test-bed. The power line channel consists of indoor 2.5 mm electrical cable created using the library provided in [10] based on transmission line theory [4]. Network sizes of 20 nodes as well as 50 nodes are then created to generate sensor and control data to simulate IoT use cases in residential and commercial buildings.

In addition to the parameters in Table I, the model developed and validated in [4] was re-calibrated to utilise PSD of -50dBm/Hz as well as random impulsive noise interval and duration within (1-10)s and (1-10)ms respectively. Although varying impedance is common in power lines, a fixed impedance of 50 Ω is assumed in this work.

V. RESULTS

This section presents the performance of the 6LoPLC model using the traffic analysis of the in-home monitoring and control applications. The metrics of performance considered are latency, reliability and resilience to impulsive noise. We consider the statistical distribution of the latency and packet loss in different network configurations. Device densities of 20 nodes and 50 nodes are applied to residential and commercial buildings respectively. In each case, the network performance is illustrated as box plots showing the variability of the delay and packet loss.

A. Uni-directional Delay

The statistical distribution of latency for different application data sizes over the 6LoPLC network are presented in Fig. 4. Various payload sizes; 16, 32 64 128 and 256 bytes as well as 20-device and 50-device BANs are considered.

Fig. 4 describes of the spread of latency experienced by indoor IoT applications including the maximum and minimum delays with various message sizes. The latency generally increases with the number of end nodes in the BAN. In each of the box plots in Fig. 4, the upper and lower whiskers correspond to the lower and upper bounds of delays. Thus, the distance between the whiskers is the full range of delays that are feasible, while the inter-quartile range indicates the interval within which the latency is more likely to vary.

In a 20-node network such as home, for message size of 32 bytes, the minimum achievable delay is about 54 ms. For 128 bytes and 256 bytes payloads, the latencies range within (157-177)ms and (280-284)ms respectively. However, for large commercial buildings comprising 50 nodes, such as

offices or shopping malls, Fig. 4b shows that for 32 bytes and 64 bytes, the achievable minimum latencies are 155 ms and 193 ms respectively. In the latter scenario, the higher number of nodes in the commercial building results in higher contention. Accordingly, for application payloads of 16 bytes and 64 bytes in a 20-device BAN, 75% of the latency samples will likely be < 91 ms and < 110.5 ms respectively.

B. Reliability

Although many IoT applications are delay-tolerant and do not require strict ultra-low latency, however, high reliability and availability are often necessary. In Fig. 5, we present the reliability of the Hanadu-based 6LoPLC system using packet loss as a measure of performance. Based on the system configuration, it is seen that for message lengths ≥ 64 bytes, reliability degrades significantly. For example, with payload size of 128 bytes, about 75% of the messages will experience up to 158 packet loss whereas with 64 bytes, the loss will range between 1-10 packets. It is also observed in this figure that the maximum number of lost packets increases by 148 when the application data size is doubled from 64 bytes to 128 bytes.

Fig. 6 compares the transmit power of Hanadu with other low order modulation schemes. In order to guarantee a 99.9% reliability (equivalent to BER of 10^{-3}), the figure shows that, Hanadu yields about 5.05 dB in energy savings compared with HomePlug Green PHY specification for in-building connectivity. The savings mainly arise from the use of DBPSK compared with HomePlug Green PHY that only supports quadrature PSK (QPSK) [11]. It should however be noted that while HomePlug Green PHY offers 4-10Mbps [11], Hanadu was targeted at maximum of 250 kbps (theoretical). In fact, the parametric model of Hanadu reported maximum of about 76 kbps [4]. In spite of this, Hanadu kits successfully supported temperature sensing and light control with acceptable performance [4]. Thus, considering the small payloads in most indoor IoT applications such as in-building sensing and control where there is more emphasis on resilience than data rate, Hanadu promises a lower energy requirement for the indoor IoT transceivers.

C. Use-Cases

1) *Monitoring: Periodic update (e.g. load sub-metering, Solar PV)*: In smart cities and smart grid, it seems appropriate to use wireless technologies in in-home scenarios such as temperature and air quality sensing. However, for main-connected devices such as boilers, electric heaters, etc, by embedding 6LoPLC chips, per device energy consumption data can be obtained and sent to the in-home gateway for onward transmission to the IoT cloud over the longhaul. This can provide a potentially cheaper alternative to the installation of sub-meters in critical devices. Fig. 4 shows that in buildings with 20 nodes (residential) and 50 nodes (commercial building) using a payload size of 16 bytes, the minimum expected latency are 48 ms and 129 ms respectively.

2) *Control: On-demand (e.g. light level, PEV, washing machine, dish washer, etc)*: Some applications receive multiple messages per day such as light level control, plug-in

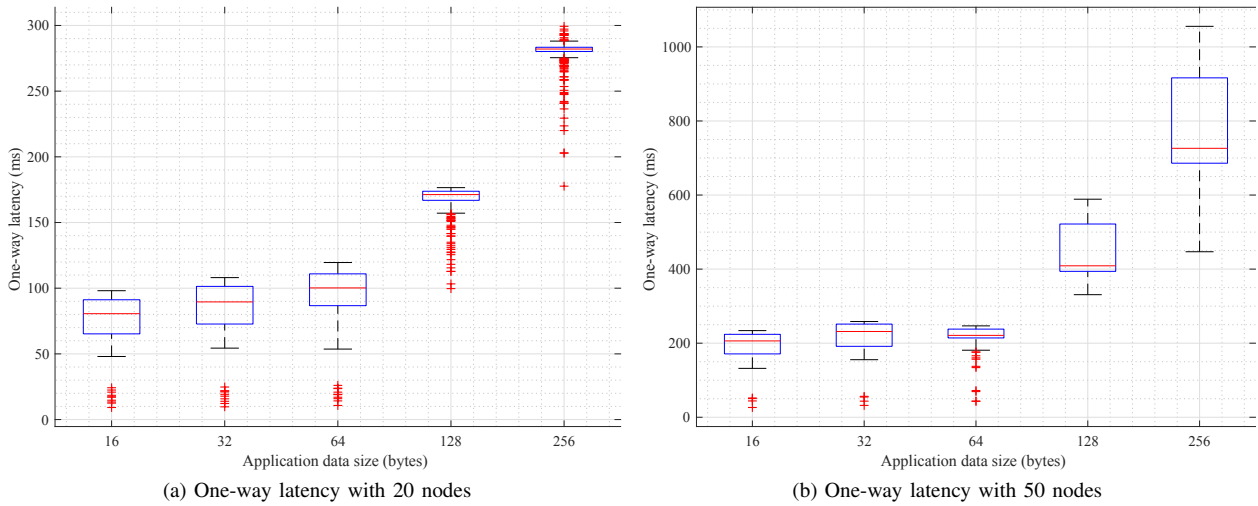

Figure 4: Latency vs number of payload size for various number of nodes

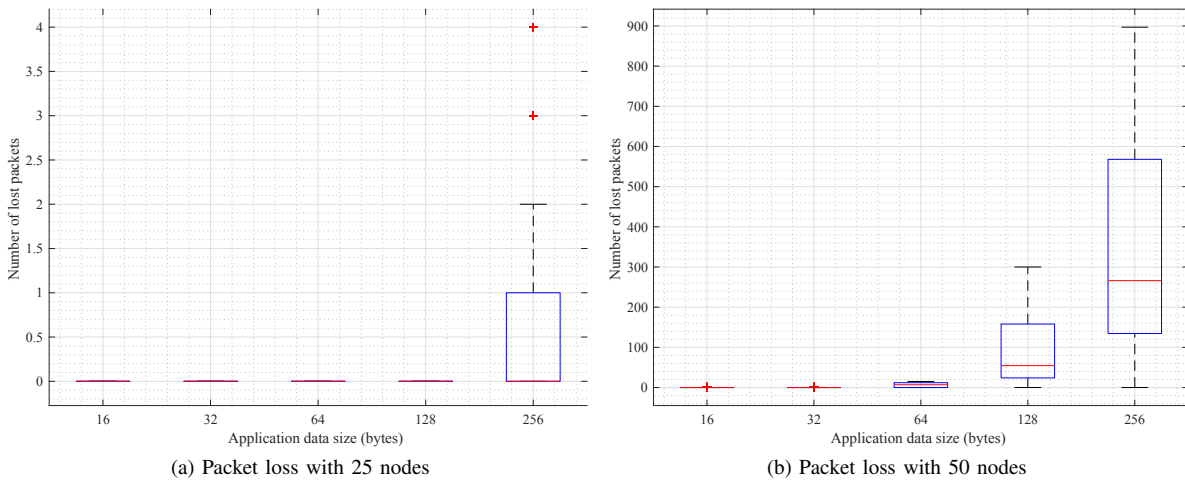

Figure 5: Packet loss vs data size over 6LoPLC network in buildings with 25 and 50 nodes

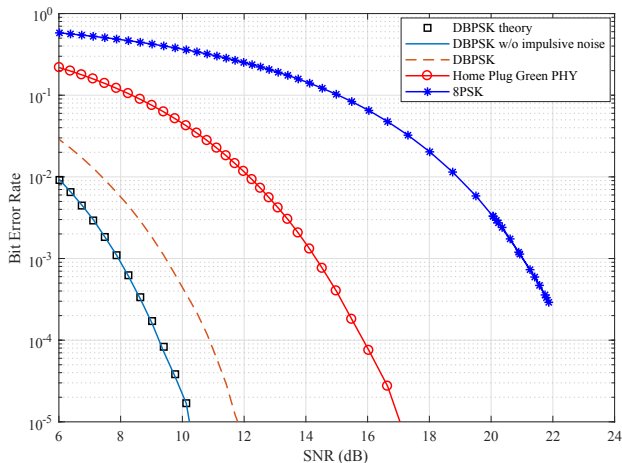

Figure 6: BER vs SNR comparison between Hanadu, HomePlug Green PHY and 8PSK

vehicles (PEV) charging, etc. In such applications, communication is event-driven. For instance, in PEV charging, control message can be sent to discontinue charging as part of demand response program at peak periods or regulate the light level provided in work spaces, depending on occupation.

VI. CONCLUSION

In smart cities, low-power consumption in end nodes is a major requirement. In this study, we demonstrated the use of low-power PLC for in-door IoT applications. By employing a low data rate, reduced MTU size as well as low-order modulation, energy requirement of 6LoPLC is reduced relative the conventional systems. Based on the 6LoPLC implementation with the Hanadu chips, it was found that energy saving of about 5.05 dB can be achieved in signal modulation. The results also showed that delays of 48 ms and 129 ms are feasible in residential and commercial buildings respectively, provided the payloads do not exceed 16 bytes. These delays are generally within acceptable bands since most IoT applications are not strictly real-time and do not require the ultra-low latency in conventional data networks.

ACKNOWLEDGMENT

This work was carried out within the Triangulum project, funded by the European Commission under the Horizon 2020 Smart Cities and Communities programme (Grant Agreement 646578-Triangulum-H2020-2014-2015/H2020-SCC-2014).

REFERENCES

- [1] A. Mahmood, E. Sisinni, L. Guntupalli, R. Rondon, S. A. Hassan, and M. Gidlund, "Scalability analysis of a LoRa network under imperfect orthogonality," *IEEE Trans. on Ind. Informatics*, 2018.
- [2] A. Ikpehai, B. Adebisi, K. M. Rabie, K. Anoh, R. E. Ande, H. Mohammad, H. Gacanin, and M. U. M., "Low-power wide area network technologies for Internet-of-things: A comparative review," *IEEE Journal of IoT*.
- [3] A. Ikpehai, B. Adebisi, and K. Anoh, "Effects of traffic characteristics on energy consumption of IoT end devices in smart city," in *Proc. IEEE Global Inform. Infrast. and Network. Symp.*, 2018.
- [4] A. Ikpehai, B. Adebisi, K. Rabie, R. Hagggar, and M. Baker, "Experimental study of 6LoPLC for home energy management systems," *Energies*, vol. 9, no. 12, p. 1046, 2016.
- [5] P. Mannions, "Comparing low-power wireless technologies (part 1)," 2017, accessed on 16 Dec. 2018. [Online]. Available: <https://www.digikey.co.uk/en/articles/techzone/2017/oct/comparing-low-power-wireless-technologies>
- [6] M. Li and H.-J. Lin, "Design and implementation of smart home control systems based on wireless sensor networks and power line communications," *IEEE Trans. Ind. Electr.*, vol. 62, no. 7, pp. 4430–4442, 2015.
- [7] W. Bakkali, M. Tlich, P. Pagani, and T. Chonavel, "A measurement-based model of energy consumption for plc modems," in *IEEE Int. Symp. Power Line Commun. and its Appl. (ISPLC)*. IEEE, 2014, pp. 42–46.
- [8] W. Bakkali, P. Pagani, and T. Chonavel, "Experimental analysis and modeling of energy consumption behaviour for MIMO PLC modems," in *IEEE Global Commun. Conf. (GLOBECOM)*. IEEE, 2015, pp. 1–5.
- [9] A. Ghiasimonfared, D. Righini, F. Marcuzzi, and A. M. Tonello, "Development of a hybrid LoRa/G3-PLC IoT sensing network: An application oriented approach," in *IEEE Int. Conf. Smart Grid Commun. (SmartGridComm)*. IEEE, 2017, pp. 503–508.
- [10] F. Aalamifar, A. Schlogl, D. Harris, and L. Lampe, "Modelling power line communication using network simulator-3," in *IEEE Global Commun. Conf. (GLOBECOM)*. IEEE, 2013, pp. 2969–2974.
- [11] H. Alliance, "The standard for in-home smart grid powerline communications: An application and technology overview; homeplug green PHY 1.1," 2012, accessed on 20 Jan. 2019. [Online]. Available: http://www.homeplug.org/media/filer_public/92/3f/923f0eb3-3d17-4b10-ac75-03c3c2855879/homeplug_green_phy_whitepaper_121003.pdf